

MAINTENANCE

MAINTENANCE

1 TROUBLE TABLE

1.1 Main Control Malfunction

Table 1 Fault Display on Indoor Wired Controller

No.	Error code	Malfunction name	Origin of malfunction signal	Control description
1	E1	High pressure protection	High pressure switch	When outdoor unit detects the high pressure switch is cut off for 3s successively, high pressure protection will occur. All the loads (except the 4-way valve in heating mode) will be switched off. In this case, all the buttons and remote control signals except ON/OFF button will be disabled and cannot be recovered automatically. Switch off the unit or re-energize the unit after cutting off power to eliminate this protection.
2	E2	Freeze protection	Indoor evaporator temperature sensor	If detecting that the evaporator temperature is lower than protective temp. value after the unit has been running for a period of time under cooling or dry mode, the unit will report this fault, in which case the compressor and outdoor fan motor will be stopped. The unit will not run until evaporator temperature is higher than the protective temp. value and the compressor is stopped for 3min.
3	E3	Low pressure protection	Low pressure switch	If it is detected within 30s successively that the low-pressure switch is cut off under ON or standby state, the unit will report low pressure protection. If the fault occurs successively 3 times within 30min, the unit cannot be recovered automatically.
		Refrigerant lacking protection		If the unit reports system refrigerant lacking within 10min after turning on the unit, the unit will stop operation. If the fault occurs successively 3 times, the unit cannot be recovered automatically.
		Refrigerant recycling mode		If enter refrigerant recycling mode through special operation, E3 will be displayed. After exiting refrigerant recycling mode, the code will disappear.
4	E4	Compressor high discharge temperature protection	Compressor discharge temperature is high	If outdoor unit detects that the discharge temperature is higher than protective temp. value, the unit will report high discharge temperature protection. If the protection occurs over 6 times, the unit cannot be recovered automatically. Switch off the unit or re-energize the unit after cutting off power to eliminate this protection.
6	E6	Communication malfunction	Communication between indoor and outdoor mainboard	If the outdoor unit does not receive data from indoor unit, communication malfunction will be reported. If there is communication abnormality between display board and indoor unit, communication malfunction will be reported too.
8	E8	Malfunction of indoor fan motor	Indoor fan motor	If the indoor unit does not receive signal from indoor fan motor for 30s successively when the fan motor is operating, indoor fan motor malfunction will be reported. In this case, the unit can automatically resume operation after stopping. If the malfunction occurs 6 times within one hour, the unit cannot be recovered automatically. Switch off the unit or re-energize the unit after cutting off power to eliminate this malfunction.

No.	Error code	Malfunction name	Origin of malfunction signal	Control description
9	E9	Full water protection	Water level switch	If cut-off of water level switch is detected for 8s successively once energized, the system will enter full water protection. In this case, switch off the unit and then switch it on to eliminate this malfunction.
10	F0	Malfunction of indoor ambient temperature sensor at air return port	Indoor ambient temperature sensor	If the indoor ambient temperature sensor is detected of open circuit or short circuit for 5s successively, indoor ambient temperature sensor malfunction will be reported. The unit can automatically resume operation after the malfunction disappears. If indoor ambient temperature sensor malfunction occurs in fan mode, only the error code is displayed and the indoor unit can work normally.
11	F1	Malfunction of evaporator temperature sensor	Evaporator temperature sensor	If the indoor evaporator temperature sensor is detected of open circuit or short circuit for 5s successively, evaporator temperature sensor malfunction will be reported. The unit can automatically resume operation after the malfunction disappears. If evaporator temperature sensor malfunction occurs in fan mode, only the error code is displayed and the indoor unit can work normally.
12	F2	Malfunction of condenser temperature sensor	Condenser temperature sensor	If the outdoor condenser temperature sensor is detected of open circuit or short circuit for 5s successively, condenser temperature sensor malfunction will be reported. The unit can automatically resume operation after the malfunction disappears. If condenser temperature sensor malfunction occurs in fan mode, only the error code is displayed and the indoor unit can work normally.
13	F3	Malfunction of outdoor ambient temperature sensor	Outdoor ambient temperature sensor	If the outdoor ambient temperature sensor is detected of open circuit or short circuit for 5s successively, outdoor ambient temperature sensor malfunction will be reported. The unit can automatically resume operation after the malfunction disappears. If outdoor ambient temperature sensor malfunction occurs in fan mode, only the error code is displayed and the indoor unit can work normally.
14	F4	Malfunction of discharge temperature sensor	Discharge temperature sensor	If the outdoor discharge temperature sensor is detected of open circuit or short circuit for 5s successively after the compressor has been operating for 3min, outdoor discharge temperature sensor malfunction will be reported. The unit can automatically resume operation after the malfunction disappears.
15	F5	Malfunction wired controller temperature sensor	Wired controller	If the wired controller detects open circuit or short circuit of its temperature sensor for 5s successively, wired controller temperature sensor malfunction will be reported.
18	ee	Malfunction of outdoor drive memory chip	Outdoor drive board	If the memory chip of outdoor drive board is broken, the unit cannot be started. The unit cannot be recovered automatically. If the malfunction cannot be eliminated after switching off the unit and then energizing the unit for several times, please replace the outdoor drive board.
20	H3	Compressor overload protection	Compressor overload switch	If it is detected within 3s successively that the overload switch is cut off under ON or standby state, the unit will report overload protection. If the fault occurs successively 3 times, the unit cannot be recovered automatically. Switch off the unit or re-energize the unit after cutting off power to eliminate this protection.

No.	Error code	Malfunction name	Origin of malfunction signal	Control description
21	H4	Overload protection	Evaporator temperature, condenser temperature	If outdoor unit detects that the tube temperature is higher than protective temp. value, the unit will report overload protection. The unit will not restart operation until tube temperature is lower than the protective temp. value and the compressor is stopped for 3min. If the protection occurs over 6 times, the unit cannot be recovered automatically. Switch off the unit or re-energize the unit after cutting off power to eliminate this protection.
23	H6	Malfunction of outdoor fan motor	Outdoor fan motor	If the outdoor unit does not receive signal from outdoor fan motor for 30s successively when the fan motor is operating, outdoor fan motor malfunction will be reported. In this case, the unit can automatically resume operation after stopping. If the malfunction occurs 6 times within one hour, the unit cannot be recovered automatically. Switch off the unit or re-energize the unit after cutting off power to eliminate this malfunction.
32	U7	Direction changing malfunction of 4-way valve	4-way valve	After the compressor starts operation in heating mode, if the outdoor unit detects the difference between evaporator temperature and indoor ambient temperature is lower than the protective value for 10min successively, direction changing malfunction of 4-way valve will be reported and the outdoor unit will stop operation. The unit can automatically resume operation in the first two malfunctions. If the malfunction occurs 3 times, the unit cannot be recovered automatically. Switch off the unit or re-energize the unit after cutting off power to eliminate this malfunction.
35	P6	Communication malfunction between main control and drive	Communication between main control board and drive board	If the outdoor main control board does not receive data from drive board, communication malfunction between main control and drive will be reported. This malfunction can be eliminated automatically.
47	EE	Malfunction of outdoor main control memory chip	Outdoor main control board	If the memory chip of outdoor main control board is broken, the unit cannot be started. The unit cannot be recovered automatically. If the malfunction cannot be eliminated after switching off the unit and then energizing the unit for several times, please replace the outdoor main control board.

1.2 Description of Drive Malfunction

Main board dual 8 numeral tube Display Codes for Outdoor Unit of 24~60k

Malfunction Item	Indoor Unit Display	Outdoor unit display of dual 8 numeral tube
DC busbar over-voltage protection	PH	PH
IPM or PFC over-temperature protection	P8	P8
Current sense circuit error	Pc	Pc
IPM or PFC temperature sensor error	P7	P7
Compressor current protection	P5	P5
DC busbar under-voltage protection	PL	PL
Compressor startup failure	Lc	Lc
Drive module reset	P0	P0
Compressor motor desynchronizing	H7	H7
Phase loss	Ld	Ld
Drive-to-main-control communication error	P6	P6
IPM protection	H5	H5
Compressor overload protection	H3	H3
AC current protection (input side)	PA	PA
Charging circuit error	PU	PU
PFC protection	HC	HC
DC fan error	H6	H6
Input AC voltage abnormality	PP	PP
Driving board memory chip error	ee	ee

2 FLOW CHART OF TROUBLESHOOTING

2.1 Troubleshooting Flow Chart of Main Control Malfunction

◆ E1 High Pressure Protection

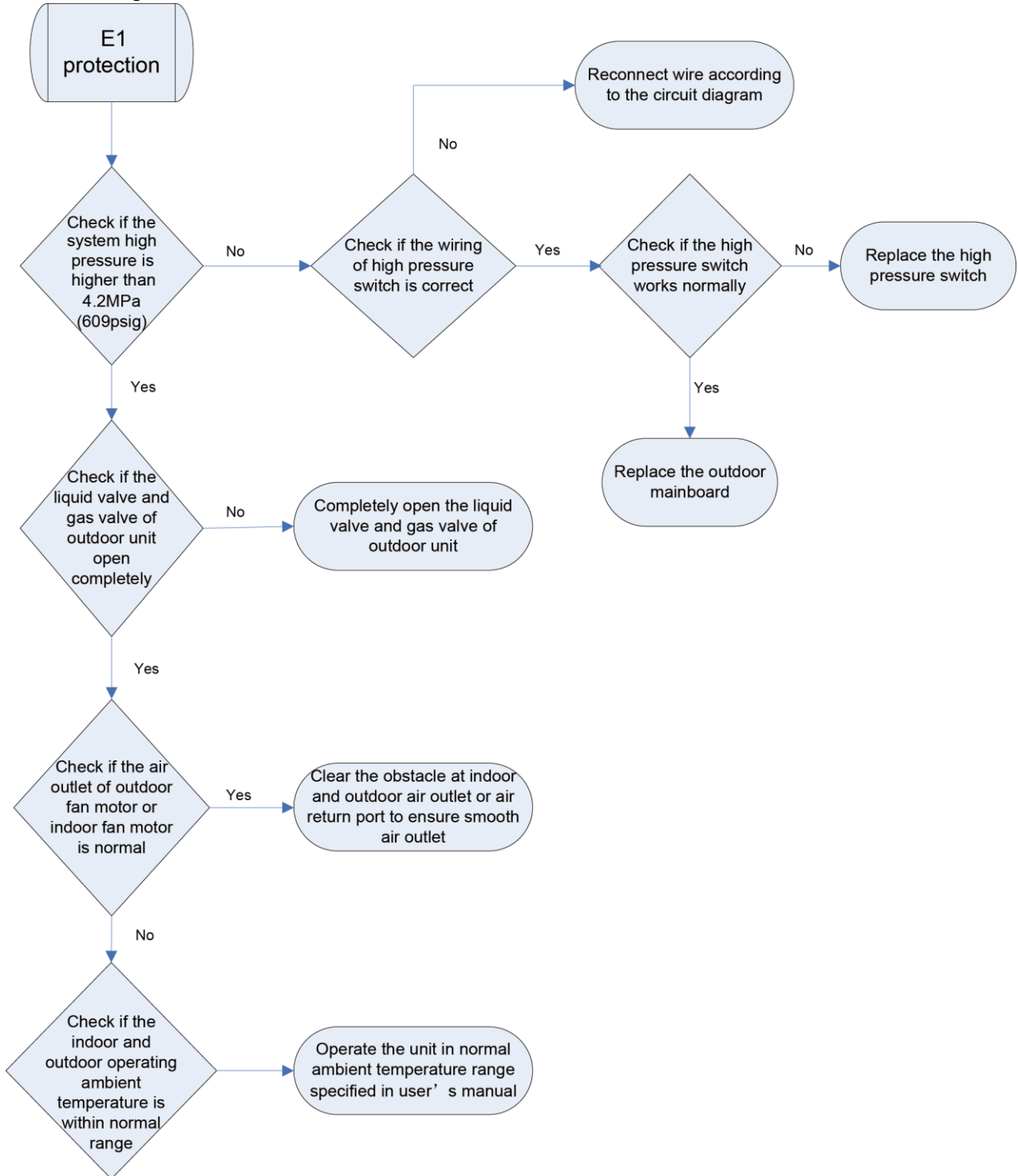

◆ E2 Freeze Protection

Freeze protection is normal protection but not abnormal malfunction. If freeze protection occurs frequently during operation, please check if the indoor filter is with filth blockage or if the indoor air outlet is abnormal. The user is required to clean the filter, check the air outlet and air return pipe periodically to ensure smooth air return and air outlet.

◆ E3 stands for three statuses:

- (1) Low pressure protection;
 - (2) Refrigerant lacking protection;
 - (3) Refrigerant recycling mode;
- 1) If enter refrigerant recycling mode through special operation, the displayed E3 is not an error code. It will be eliminated when exiting refrigerant recycling mode.
 - 2) If you do not want to have refrigerant lacking protection, you can enter the debugging mode through wired controller and then cancel the refrigerant lacking protection mode.

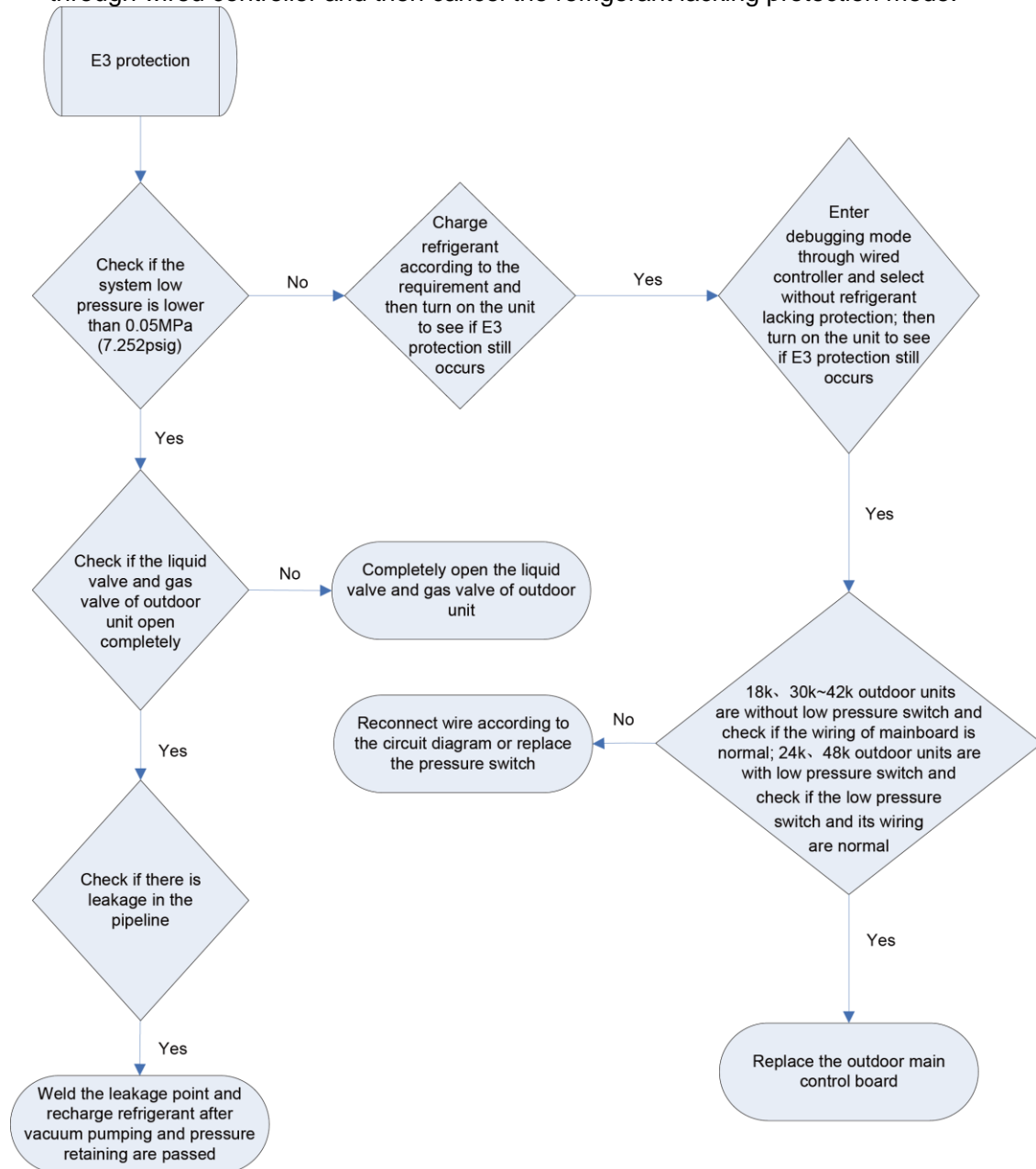

◆ E4 Discharge Protection

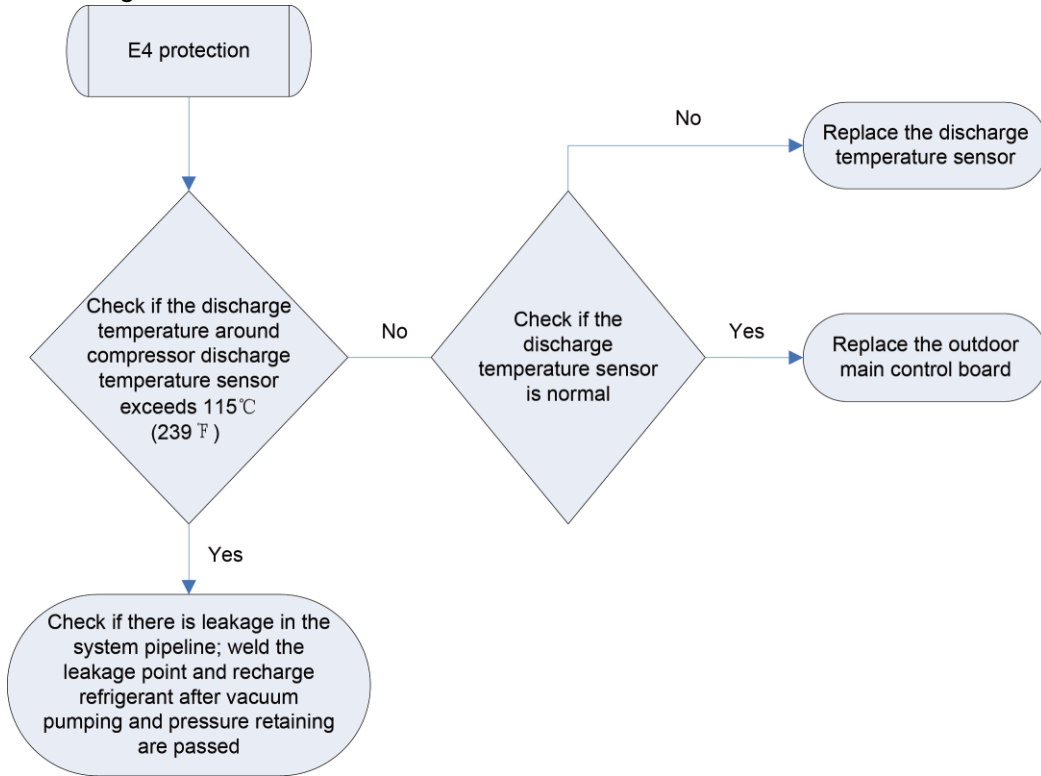

◆ E6 Communication Malfunction

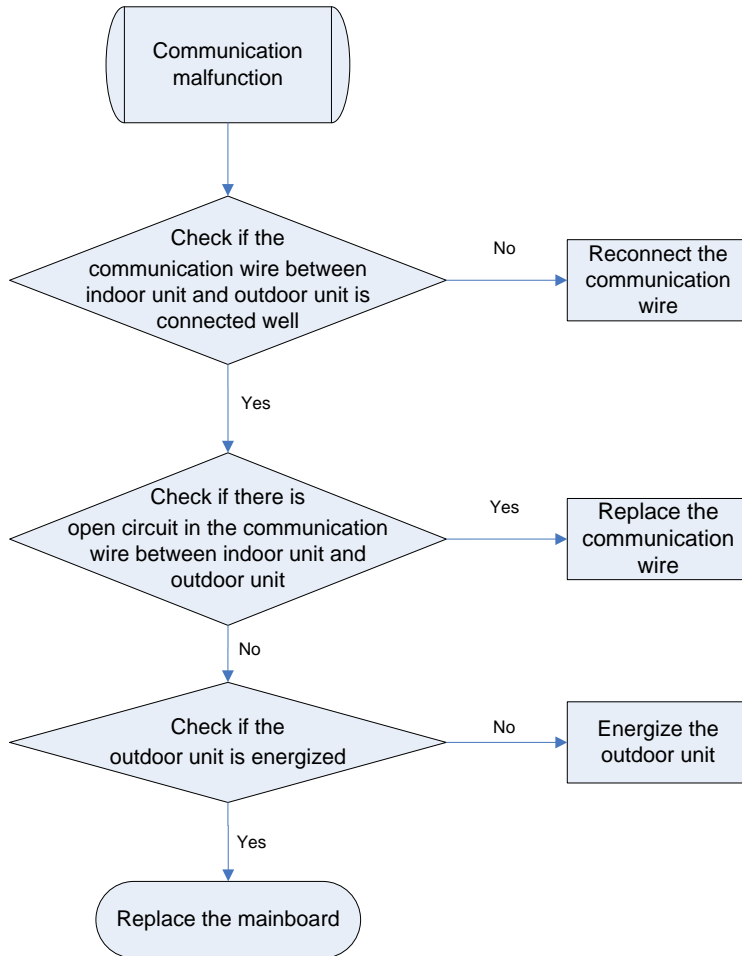

◆ E9 Full Water Protection

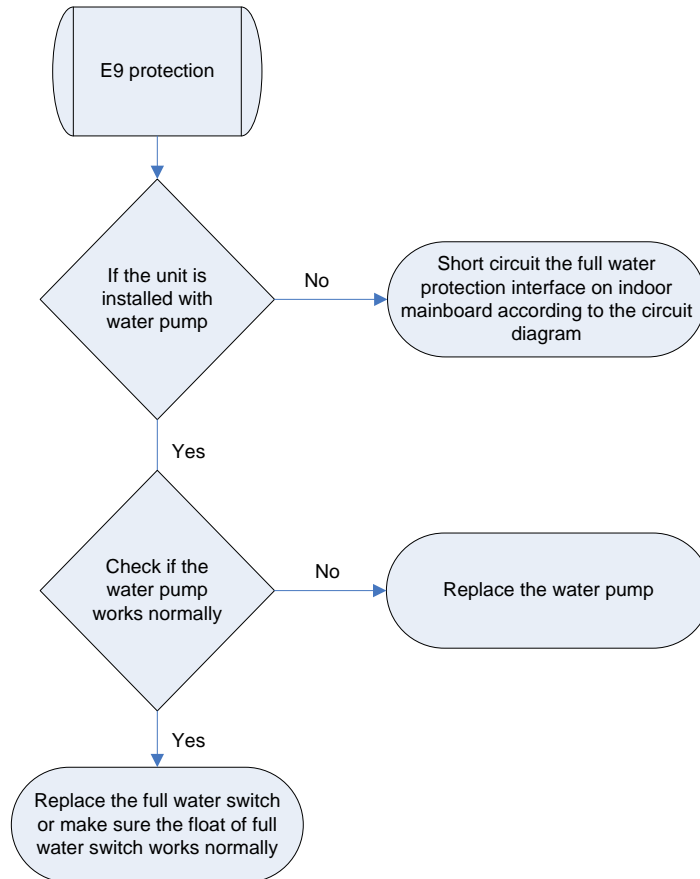

◆ F0 Malfunction of Indoor Ambient Temperature Sensor

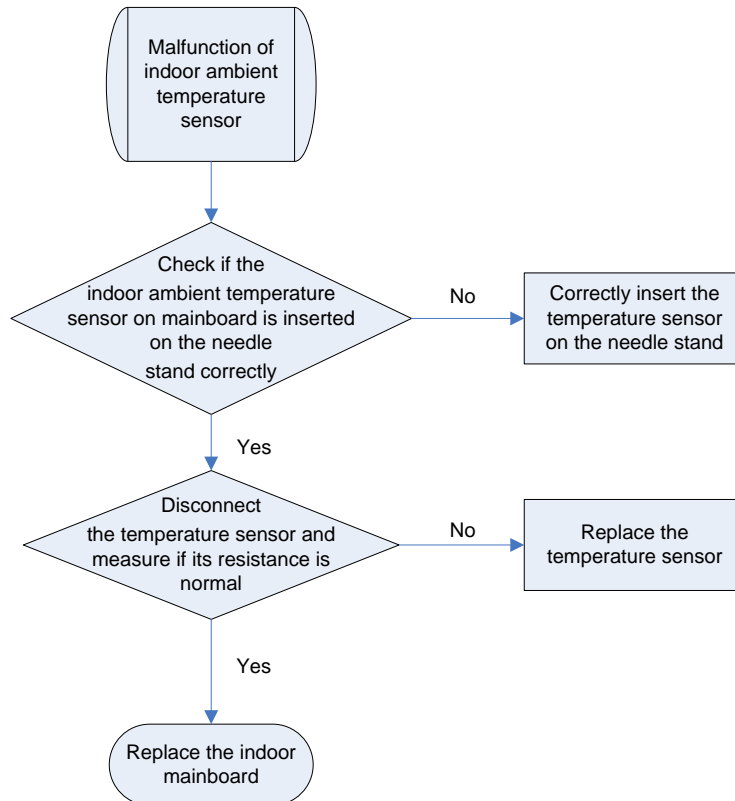

◆ F1 Malfunction of Evaporator Temperature Sensor

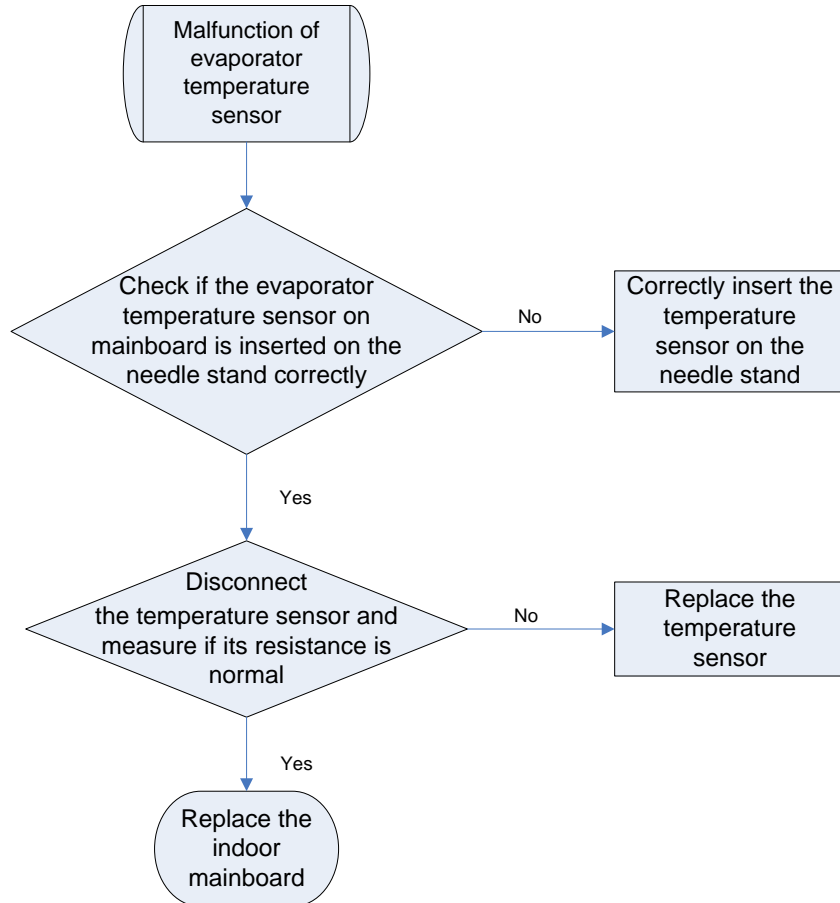

◆ F2 Malfunction of Condenser Temperature Sensor

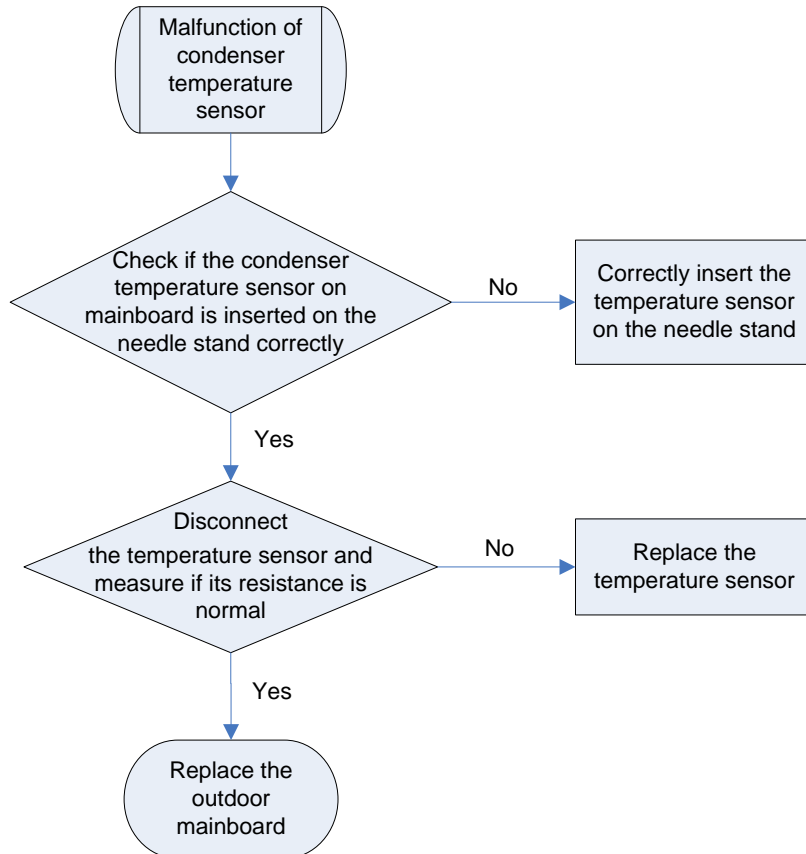

◆ F3 Malfunction of Outdoor Ambient Temperature Sensor

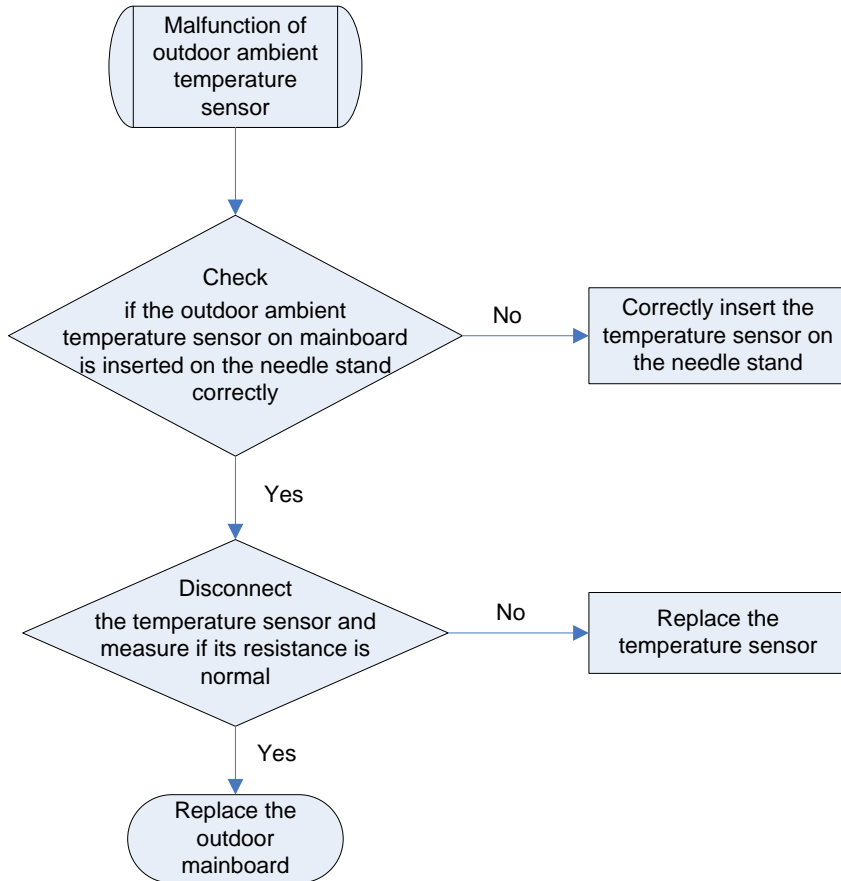

◆ F4 Malfunction of Discharge Temperature Sensor

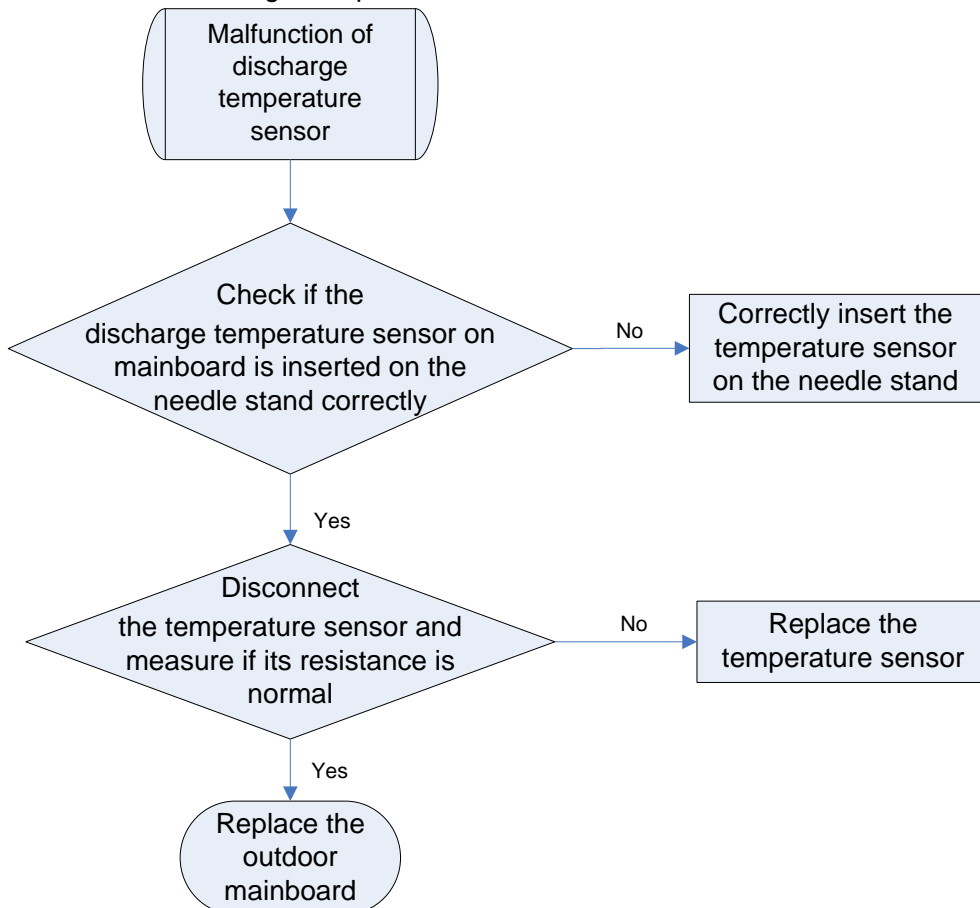

◆ F5 Malfunction of Wired Controller Temperature Sensor

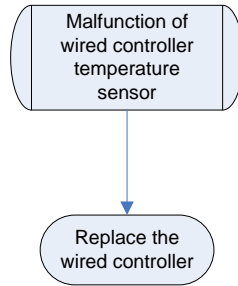

◆ H6 Malfunction of Outdoor Fan Motor

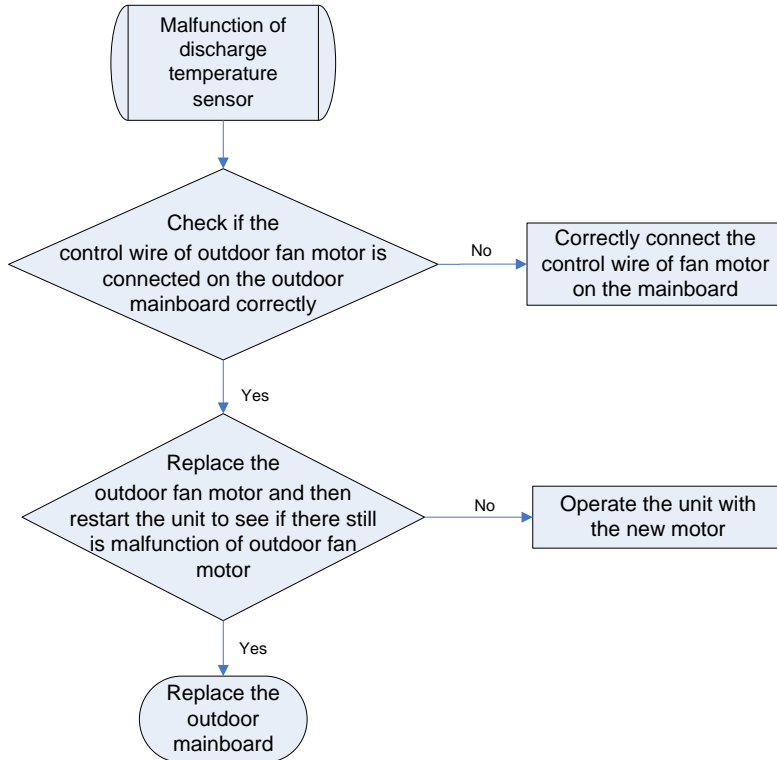

◆ E8 Malfunction of Indoor Fan Motor

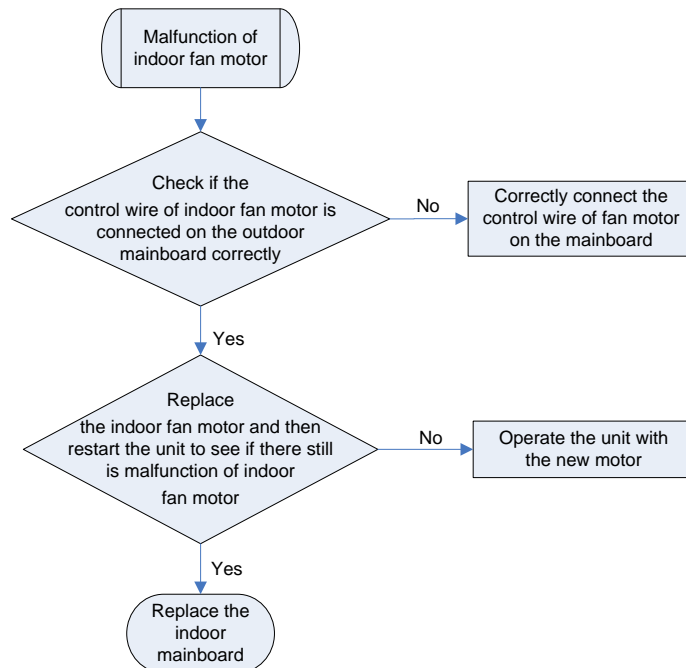

2.2 Troubleshooting Flow Chart of Drive Malfunction



Note: For Outdoor Unit Drive (Inverter) by Single-phase Motor

P0 Drive module reset

- ◆ P7 IPM or PFC temperature sensor error
- ◆ PA AC current protection (input side)
- ◆ PC Current sense circuit error
- ◆ HC PFC protection (42\48k\60k only)

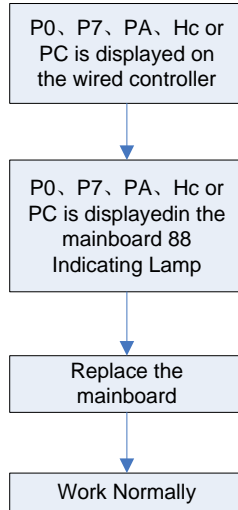

- ◆ P8 IPM or PFC over-temperature protection

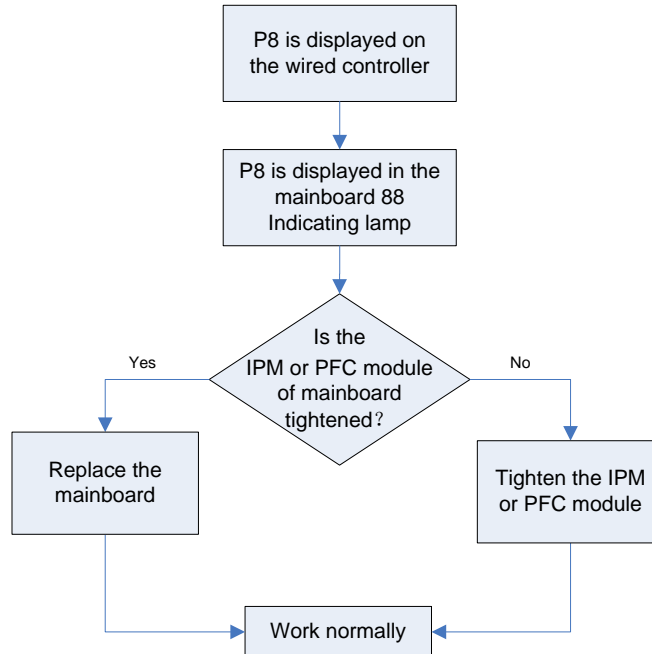

- ◆ PH DC busbar over-voltage protection
- ◆ PL DC busbar under-voltage protection

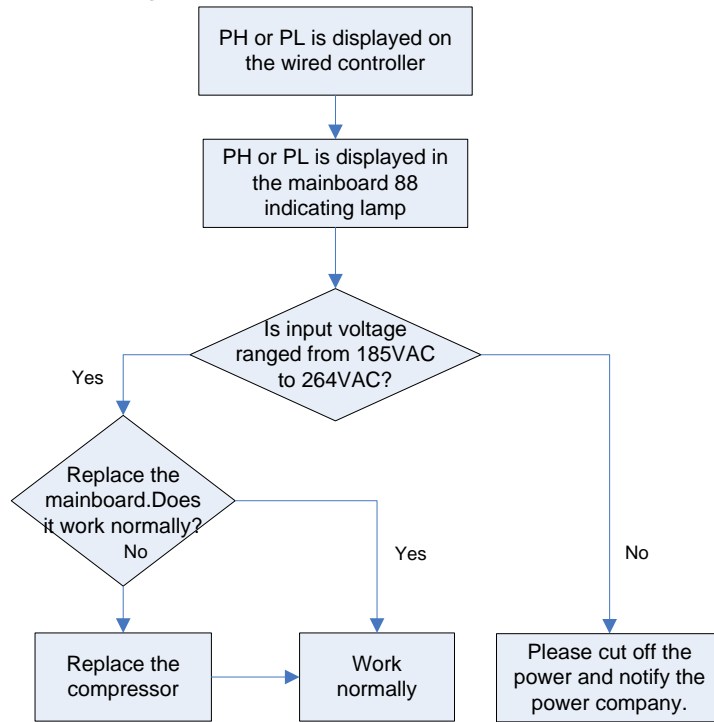

- ◆ P6 Drive-to-main-control communication error
- ◆ Lc Compressor Startup Failure

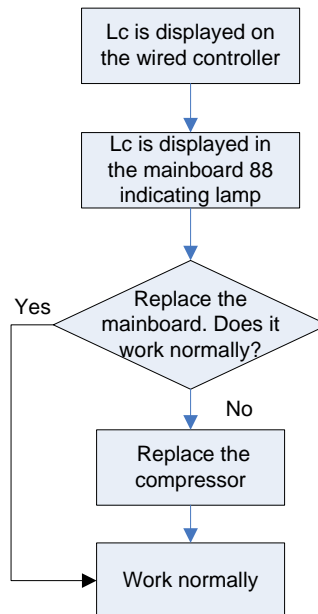

- ◆ P5 Compressor current protection
- ◆ H7 Compressor motor desynchronizing
- ◆ H5 IPM protection
- ◆ Ld Phase loss

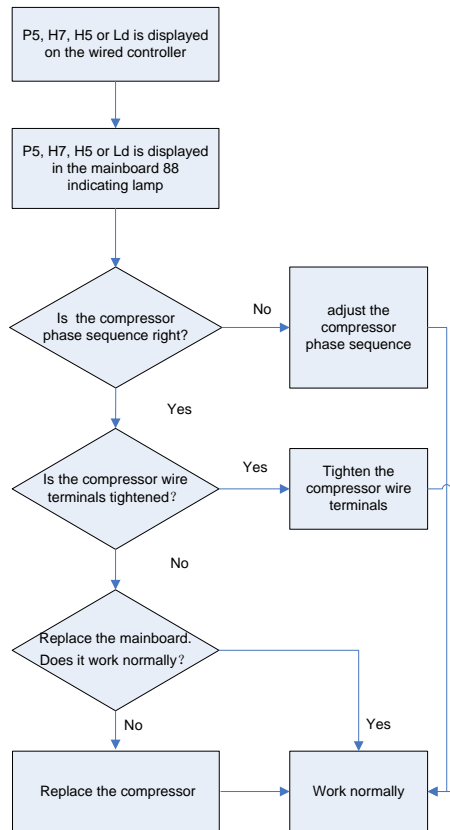

- ◆ PU Charging circuit error

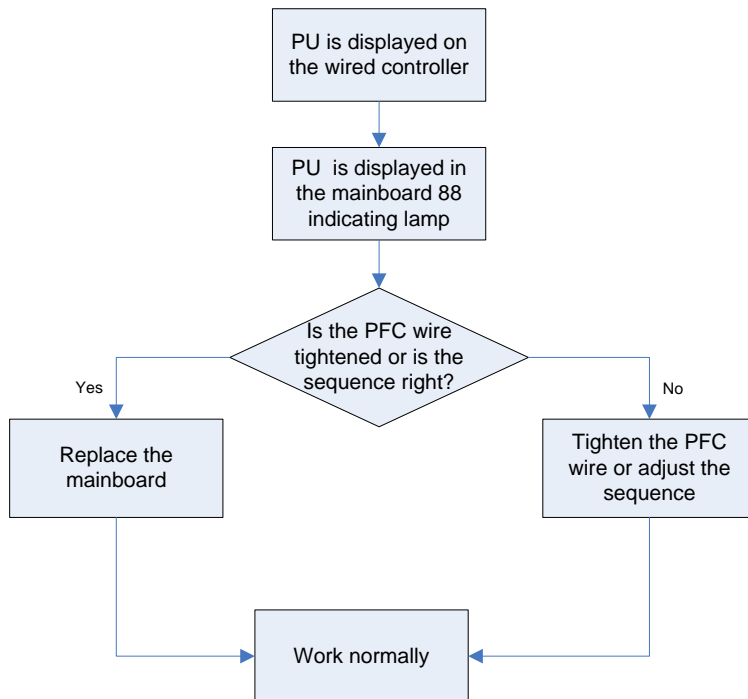

◆ ee driving board chip error

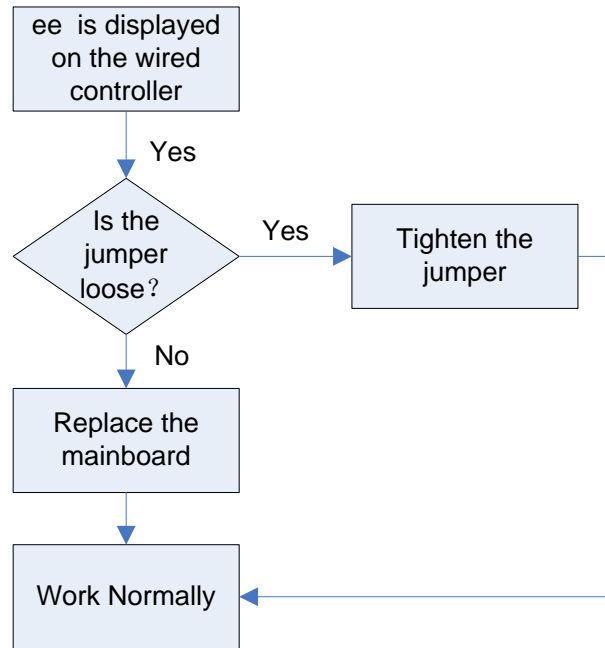

◆ H6 DC fan error

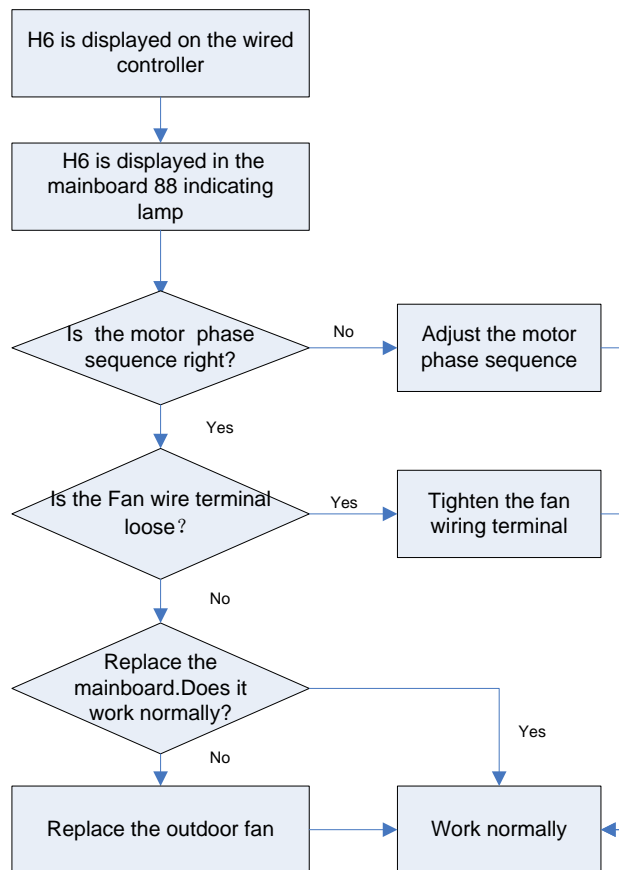

2.3 Interface

◆ Outdoor units Main Control Board

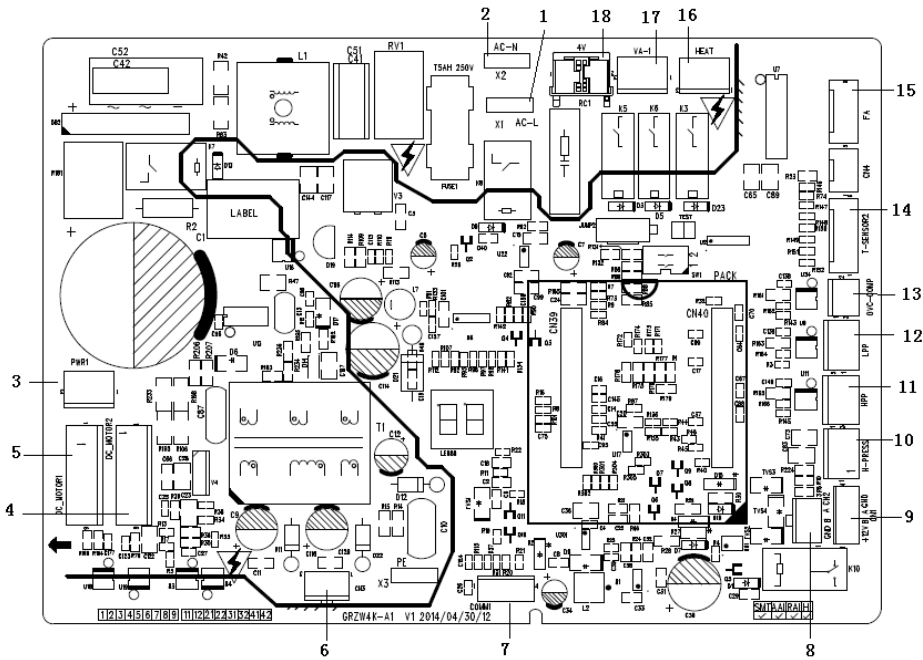

NO.	SILK-SCREEN	INTERFACE	INTERFACE INSTRUCTION
1	AC-L	Live wire input	Live wire input
2	AC-N	Neutral wire input	Neutral wire input
3	PWR 1	Control power output[1- DC bus voltage,3- GND]	Power supply interface to the drive 1-pin: DC bus voltage 3-pin: DC bus GND
4	DC_MOTOR2	DC fan motor2 1-pin: Power supply of fan motor 3-pin: Fan GND 4-pin: +15V 5-pin: Signal control 6-pin: NC	Interface of DC fan motor 1-pin: DC bus voltage 2-pin: Suspended 3-pin: DC bus GND 4-pin: +15V 5-pin: Control signal input 6-pin: Not connected
5	DC_MOTOR1	DC fan motor1 1-pin: Power supply of fan motor 3-pin: Fan GND 4-pin: +15V 5-pin: Signal control 6-pin: Signal Feedback	Interface of DC fan motor 1-pin: DC bus voltage 2-pin: Suspended 3-pin: DC bus GND 4-pin: +15V 5-pin: Control signal input 65-pin: DC fan motor feedback
6	CN3	Control power output[1-GND、2-18V、3-15V]	Power supply interface to the drive 1-pin: GND 2-pin: +18V 3-pin: +15V
7	COMM1	Communication line [1-3.3V、2-TX、3-RX、4-GND]	Communication needle stand of main control drive 1-pin: +3.3V, 2-pin: TXD

			3-pin: RXD, 4-pin: GND
8	CN2	Communication line with 1-pin GND, 2-pin B and 3-pin A)	Communication needle stand with indoor unit 1-pin: GND, 2-pin: B, 3-pin: A
9	CN1	Communication line with 1-pin plus 12V, 2-pin B, 3-pin A and 4-pin GND	Communication interface (reserved): 1-pin: +12V, 2-pin: B, 3-pin: A, 4-pin: GND
10	H-PRESS	High pressure switch for fan speed adjustment	Pressure protection switch for fan speed adjustment
11	HPP	High pressure switch for system protection (obligate)	Interface of high pressure protection
12	LPP	Low pressure switch for system protection (obligate)	Interface of low pressure protection
13	OVC-COMP	Compressor overload protection	Interface of compressor overload protection
14	T-SENSOR2	1&2 pin: Tube sensor 3&4 pin: Ambient temperature 5&6 pin: Air discharge	1&2 pin: Case temperature sensor 3&4 pin: Ambient temperature sensor 5&6 pin: Discharge temperature sensor
15	FA	Electronic expansion valve line 1 to 4-pin: Drive impulse output; 5-pin: +12V;	Interface of electronic expansion valve: 1 to 4-pin: Drive impulse output; 5-pin: +12V;
16	HEAT	Compressor electrical heater	Compressor electric heating belt
17	VA-1	Chassis electrical heater	Chassis electric heating belt
18	4V	4-way valve	4-way valve

◆ GUHD24NS3GO/GUHD36NS3GO

(1). Driving Board

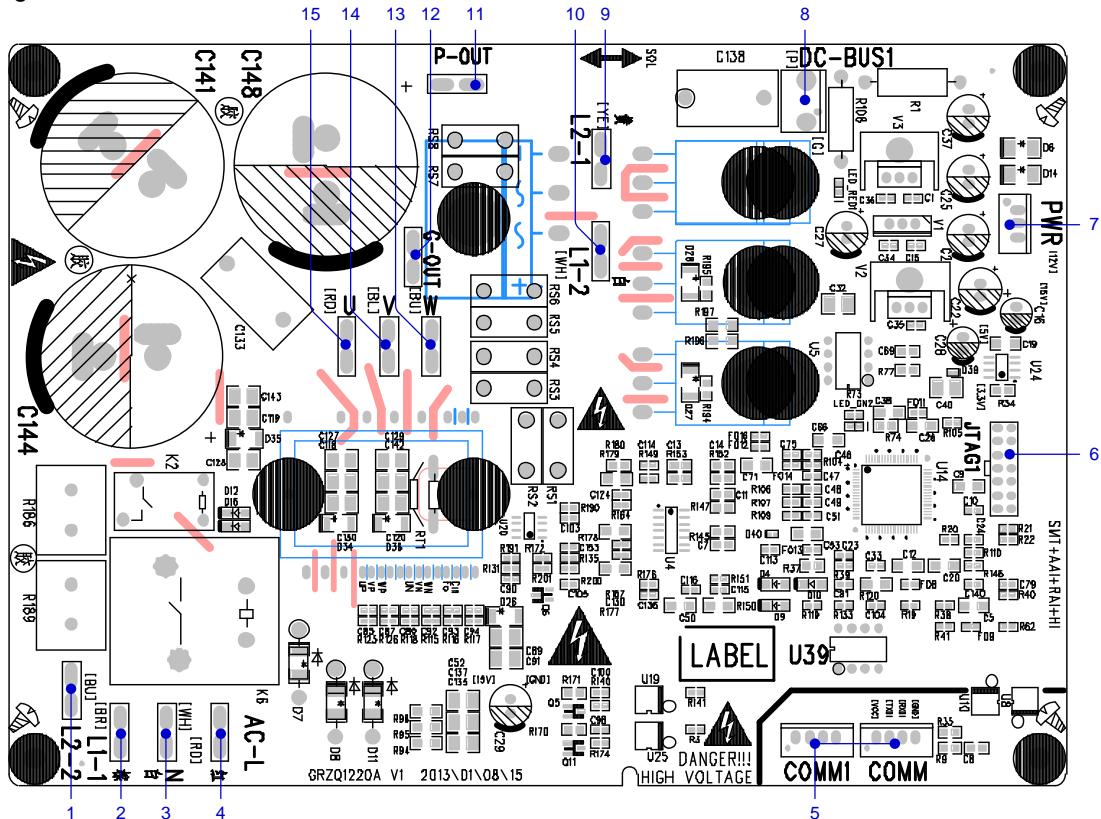

No.	Printing	Interface	No.	Printing	Interface
1	L2_2	PFC induction wire (blue)	2	L1_1	PFC induction wire (brown)
3	N	Neutral wire input (white)	4	AC-L	Live wire input (red)
5	COMM/COMM1	Communication interface	6	JTAG1	(Reserved)
7	PWR	Control power input	8	DC-BUS1	Bus electric discharging interface (for testing)
9	L2-1	PFC induction wire (yellow)	10	L1-2	PFC induction wire (white)
11	P-OUT	(Reserved)	12	G-OUT	(Reserved)
13	W	Compressor Phase W	14	V	Compressor Phase V
15	U	Compressor Phase U			

(2). Filtering Board

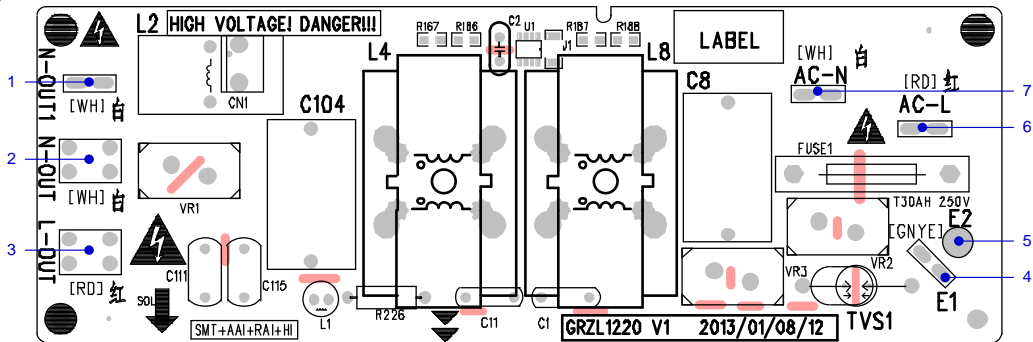

No.	Printing	Interface	No.	Printing	Interface
1	N-OUT1	Neutral wire output 1 (white)	2	N-OUT	Neutral wire output (white)
3	L-OUT	Live wire output (red)	4	E1	Grounding wire
5	E2	(Reserved)	6	AC-L	Live wire input (red)
7	AC-N	Neutral wire input (white)			

◆ GUHD42NS3GO/GUHD48NS3GO/GUHD60NS3GO

(1). Drive Board:

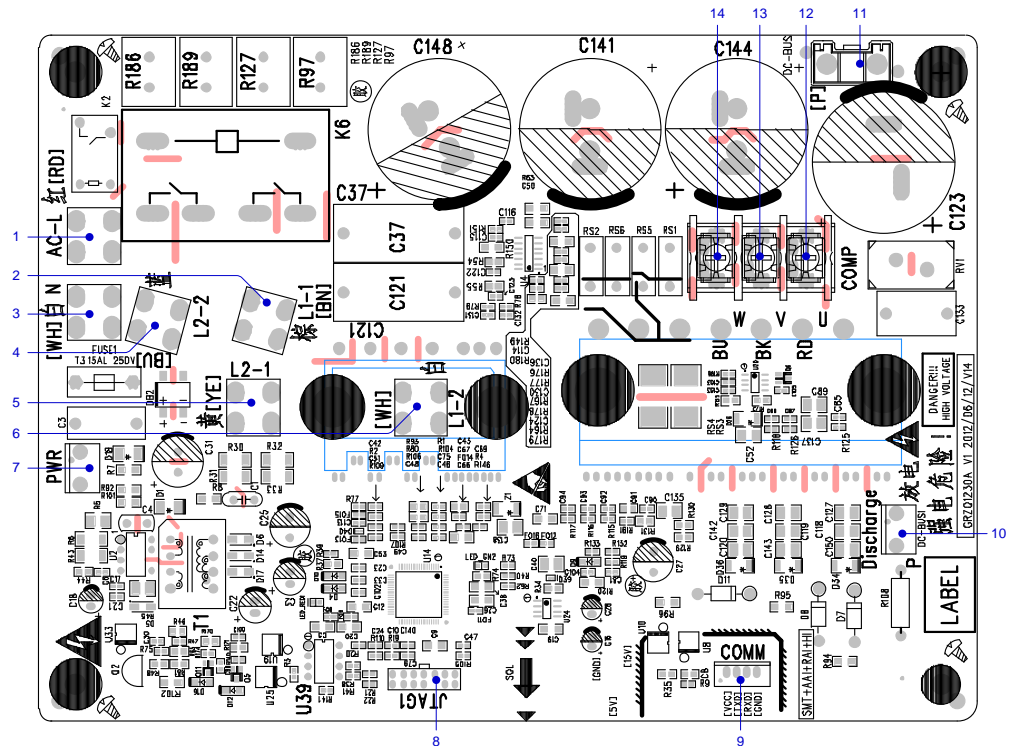

No.	Printing	Interface	No.	Printing	Interface
1	AC-L	Live wire input (red)	2	L1-1	PFC induction wire (brown)
3	N	Neutral wire input (white)	4	L2-2	PFC induction wire (blue)
5	L2-1	PFC induction wire (yellow)	6	L1-2	PFC induction wire (white)
7	PWR	Control power input	8	JTAG1	(Reserved)
9	COMM	Communication interface	10	DC-BUS1	DC bus electric discharging needle stand (for testing)
11	DC-BUS	DC bus interface (connect to filtering board)	12	U	Compressor Phase U
13	V	Compressor Phase V	14	W	Compressor Phase W

(2). Filtering Board:

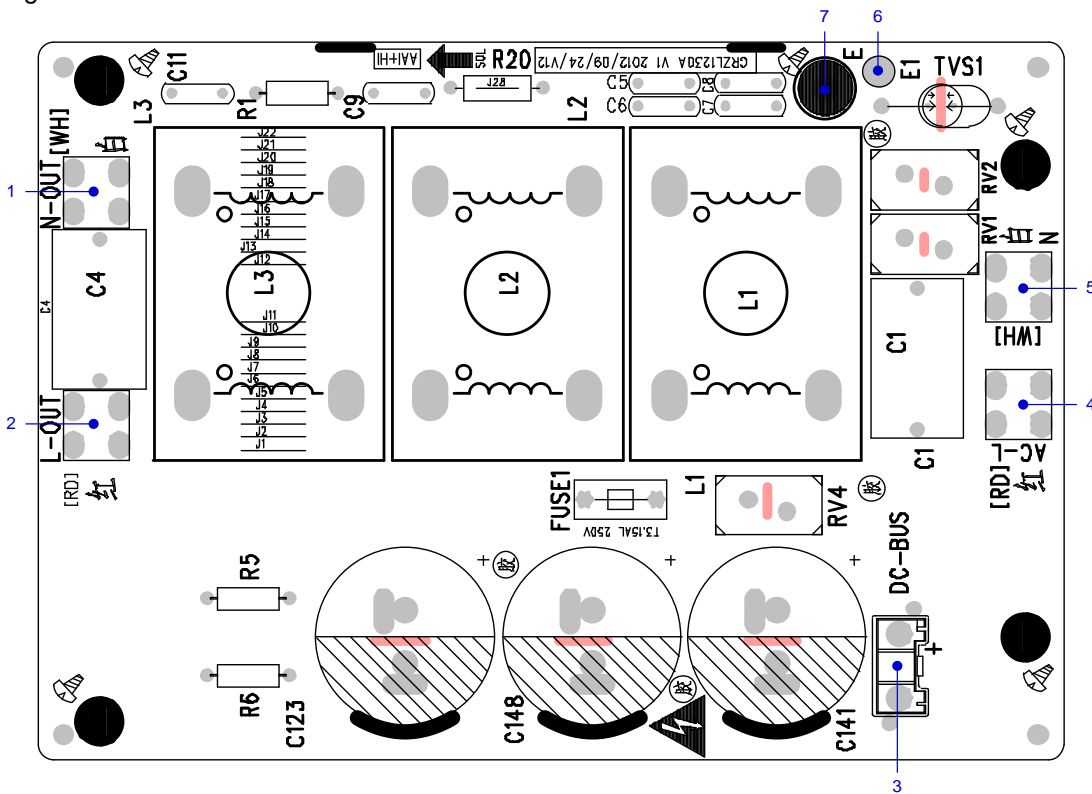

No.	Printing	Interface	No.	Printing	Interface
1	N-OUT	Neutral wire output (white)	2	L-OUT	Live wire output (red)
3	DC-BUS	DC bus interface (connect to drive board)	4	AC-L	Live wire input (red)
5	N	Neutral wire input (white)	6	E1	(Reserved)
7	E	Grounding wire (screw hole)			

2.4 IPM, PFC Testing Method

2.4.1 Method of Testing IPM Module

(1) Preparation before test: prepare a universal meter and turn to its diode option, and then remove the wires U, V, W of the compressor after it is powered off for one minute.

(2) Testing Steps

Step 1: put the black probe on the place P and the red one on the wiring terminal U, V, W respectively as shown in the following figure to measure the voltage between UP, VP and WP.

Step 2: put the red probe on the place N and the black one on the wiring terminal U, V, W respectively

as shown in the following figure to measure the voltage between NU, NV and NW.

- (3) If the measured voltages between UP, VP, WP, NU, NV, NV are all among 0.3V-0.7V, then it indicates the IPM module is normal; If any measured valve is 0, it indicates the IPM is damaged.

2.4.2 Method of Testing PFC Module Short Circuit

Note: Only for GUHD42NS3GO/GUHD48NS3GO/GUHD60NS3GO

- (4) Preparation before test: prepare a universal meter and turn to its diode option, and then remove the wires L1-2, L2-1 after it is powered off for one minute.

(5) Testing Steps

Step 1: put the black probe on the place P and the red one on the wiring terminal L1-2, L2-1 respectively as shown in the following figure to measure the voltage between L1-2P and.L2-1 P.

Step 2: put the red probe on the place N and the black one on the wiring terminal L1-2, L2-1 respectively as shown in the following figure to measure the voltage between N L1-2 and NL2-1.

- (6) If the measured voltages between L1-2P ,L2-1 P, N L1-2 , NL2-1 are all among 0.3V-0.7V, then it indicates the PFC module is normal; If any measured valve is 0, it indicates the PFC is damaged.

◆ GUHD24NS3GO/GUHD36NS3GO

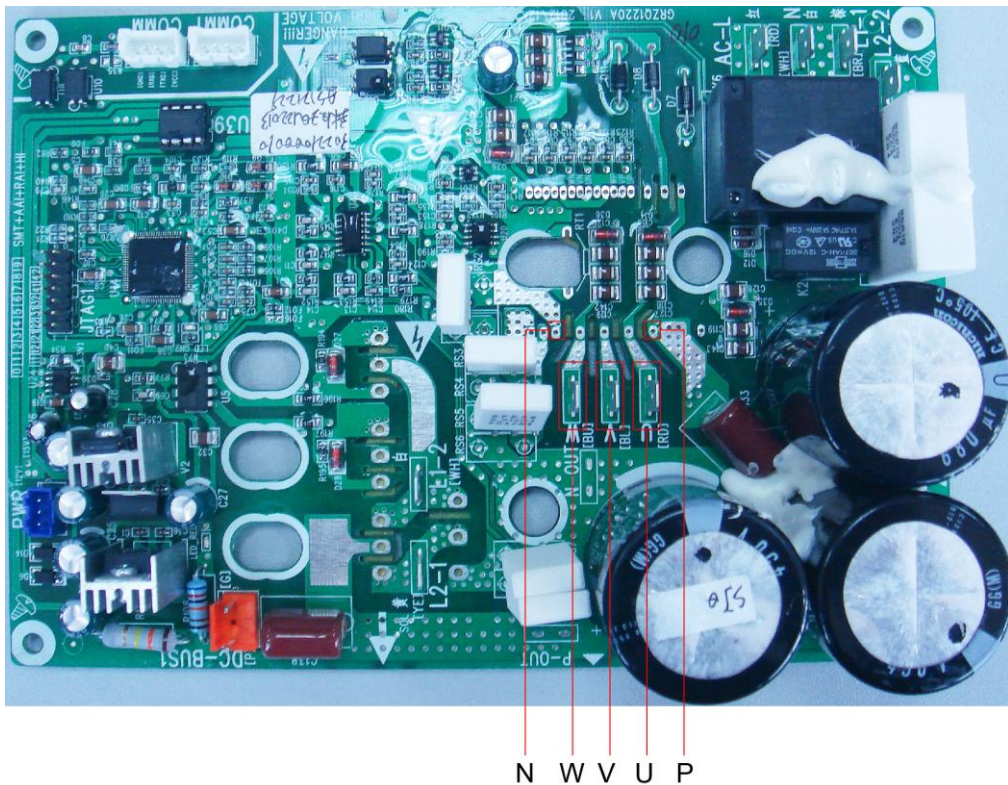

GUHD42NS3GO/GUHD48NS3GO/GUHD60NS3GO

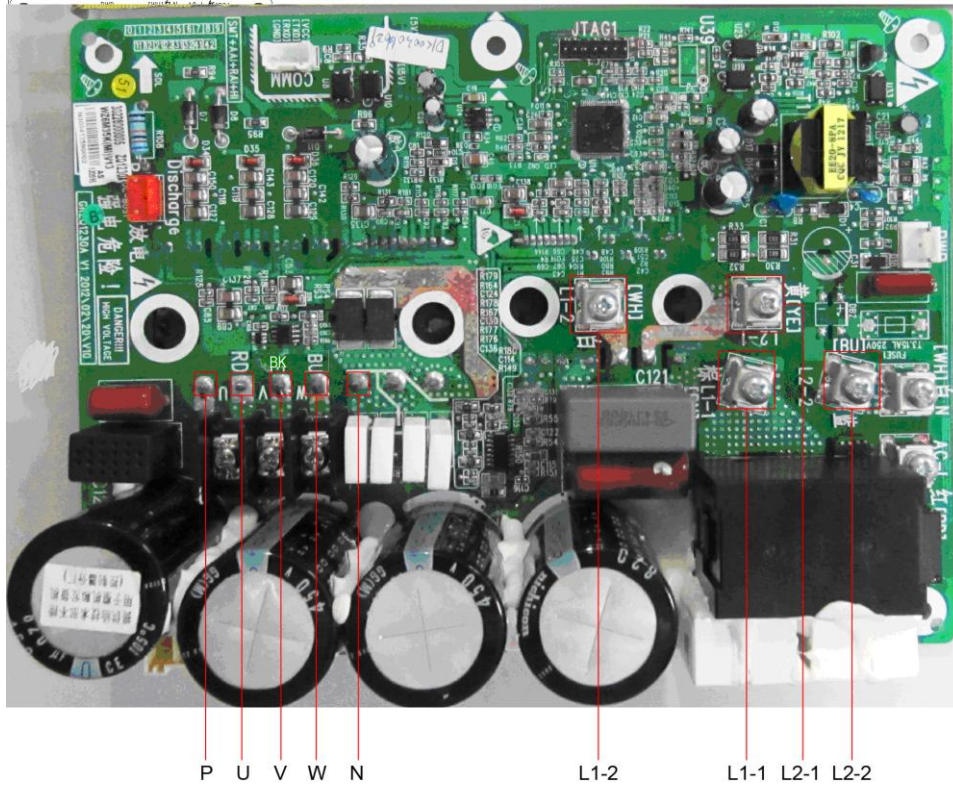

3 WIRING DIADRAM

3.1 Outdoor unit

The actual wiring should always refer to the wiring diagram of the unit.

◆ Model: GUHD24NS3GO

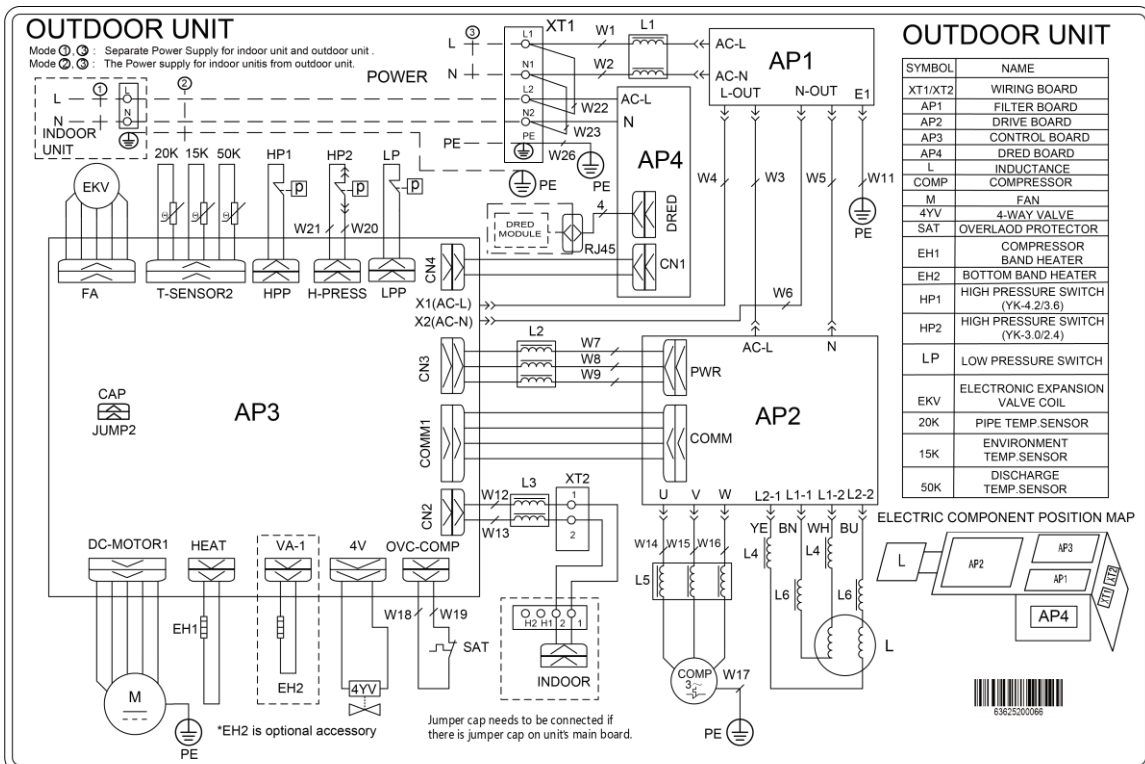

◆ Model: GUHD36NS3GO

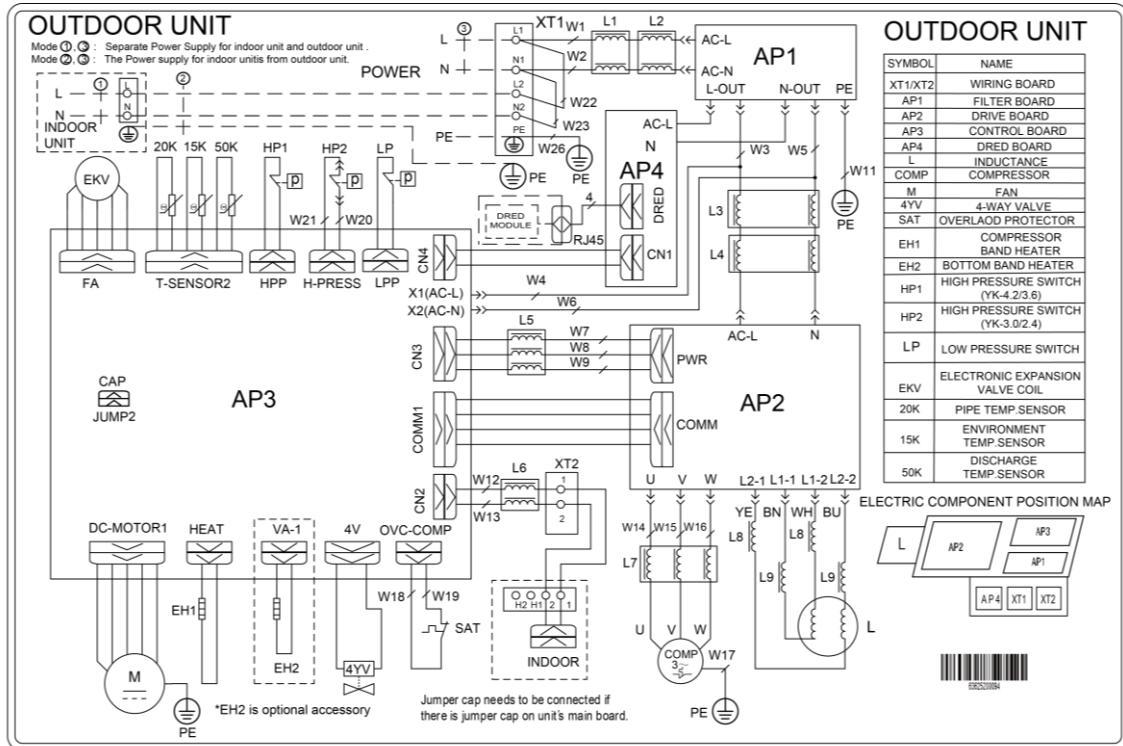

◆ Model: GUHD42NS3GO

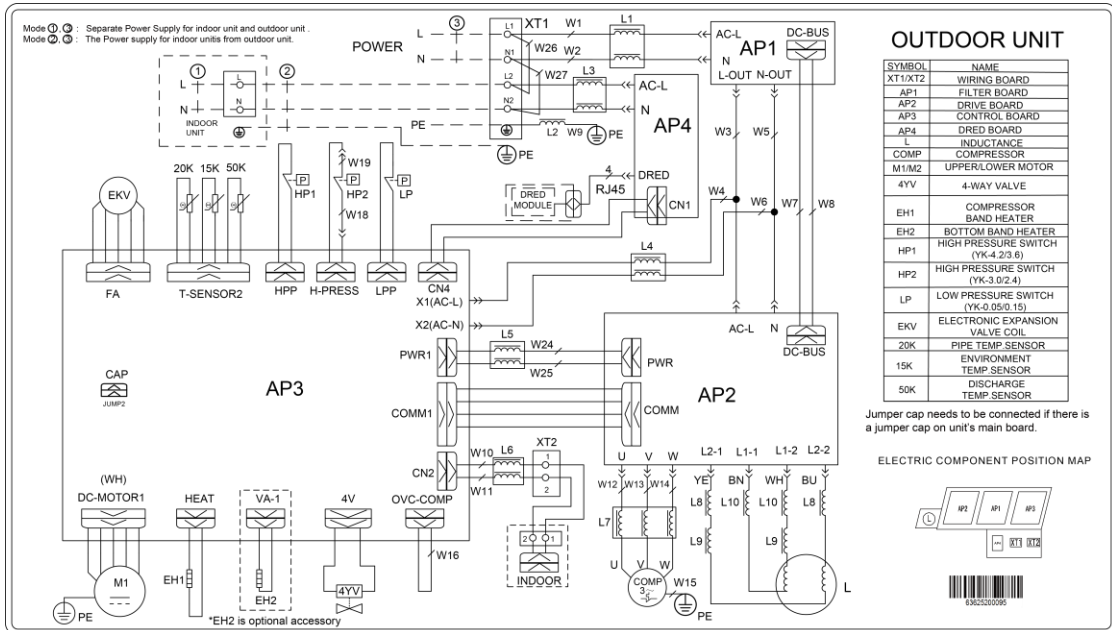

◆ Model: GUHD48NS3GO/GUHD60NS3GO

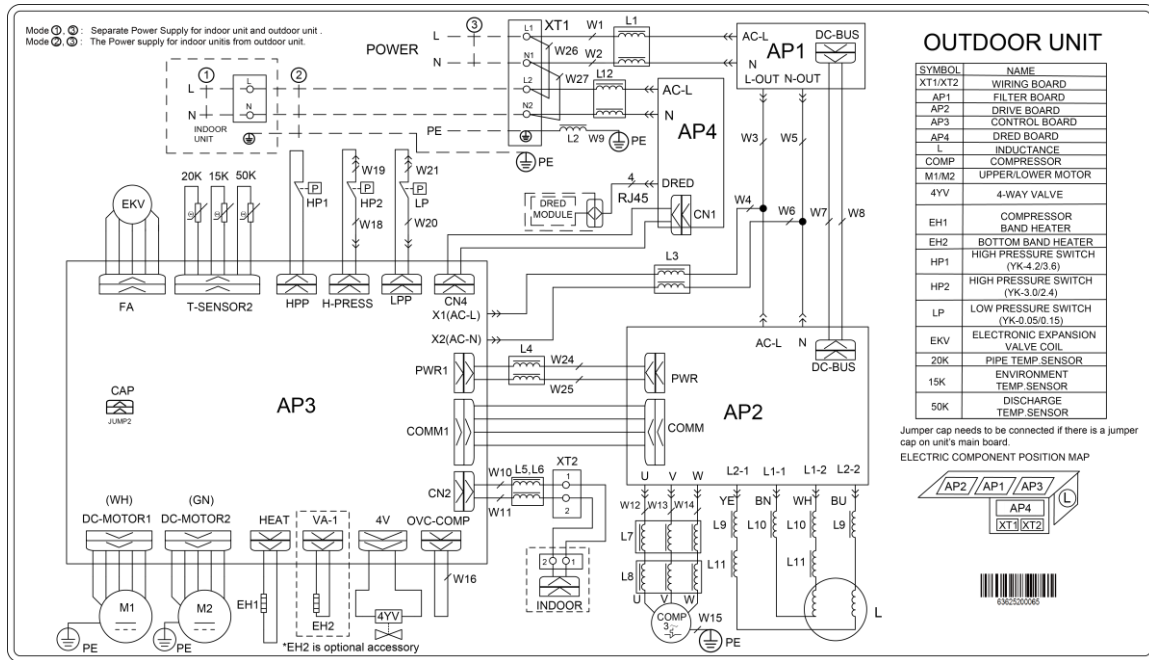

3.2 Indoor unit

The actual wiring should always refer to the wiring diagram of the unit.

3.2.1 Duct Type

◆ Model: GFH24S3GI

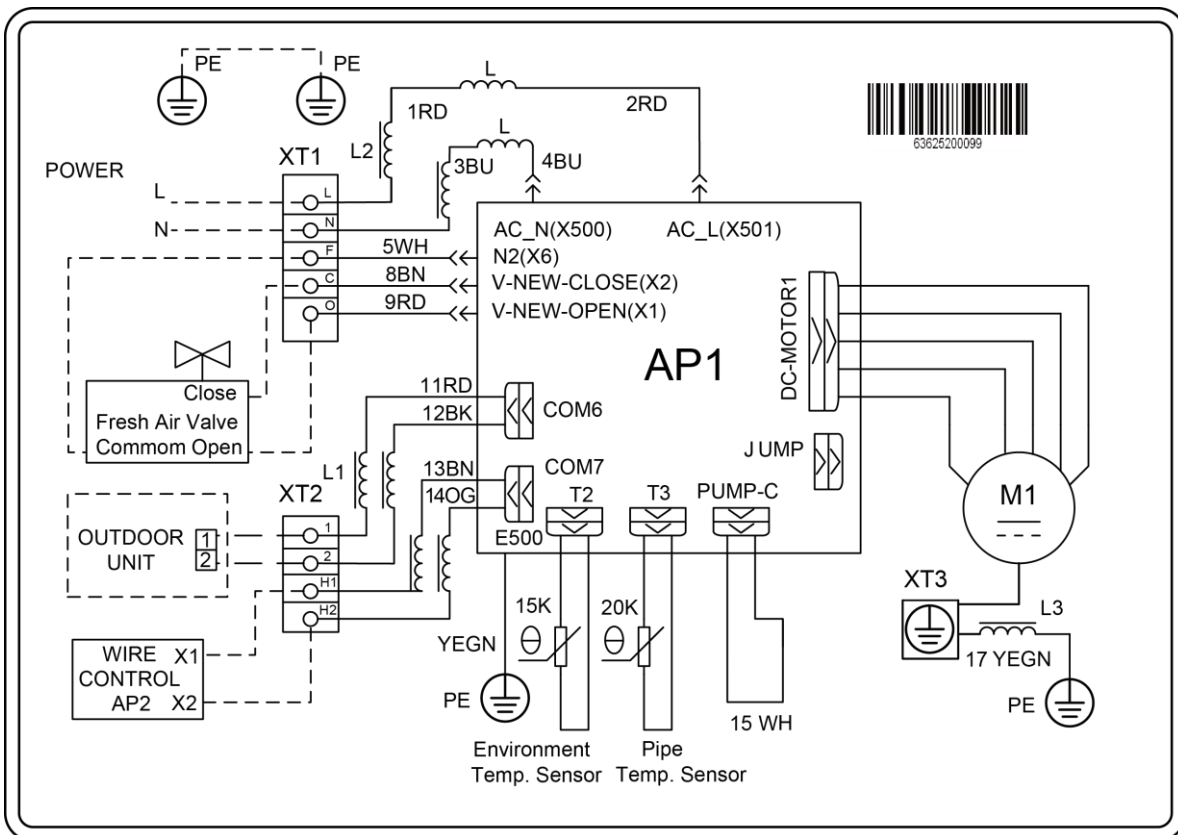

◆ GFH24S3G1I

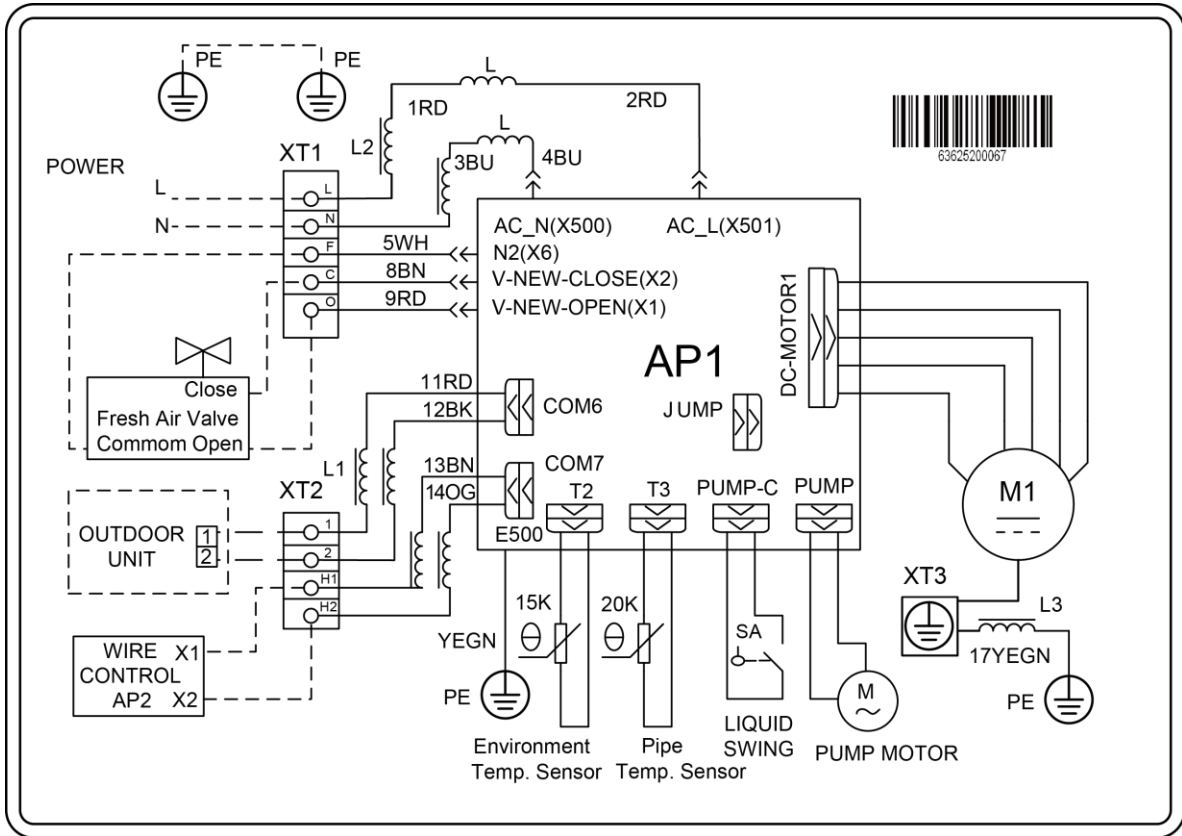

◆ Model: GFH36S3GI/GFH42S3GI/GFH48S3GI/GFH60S3GI

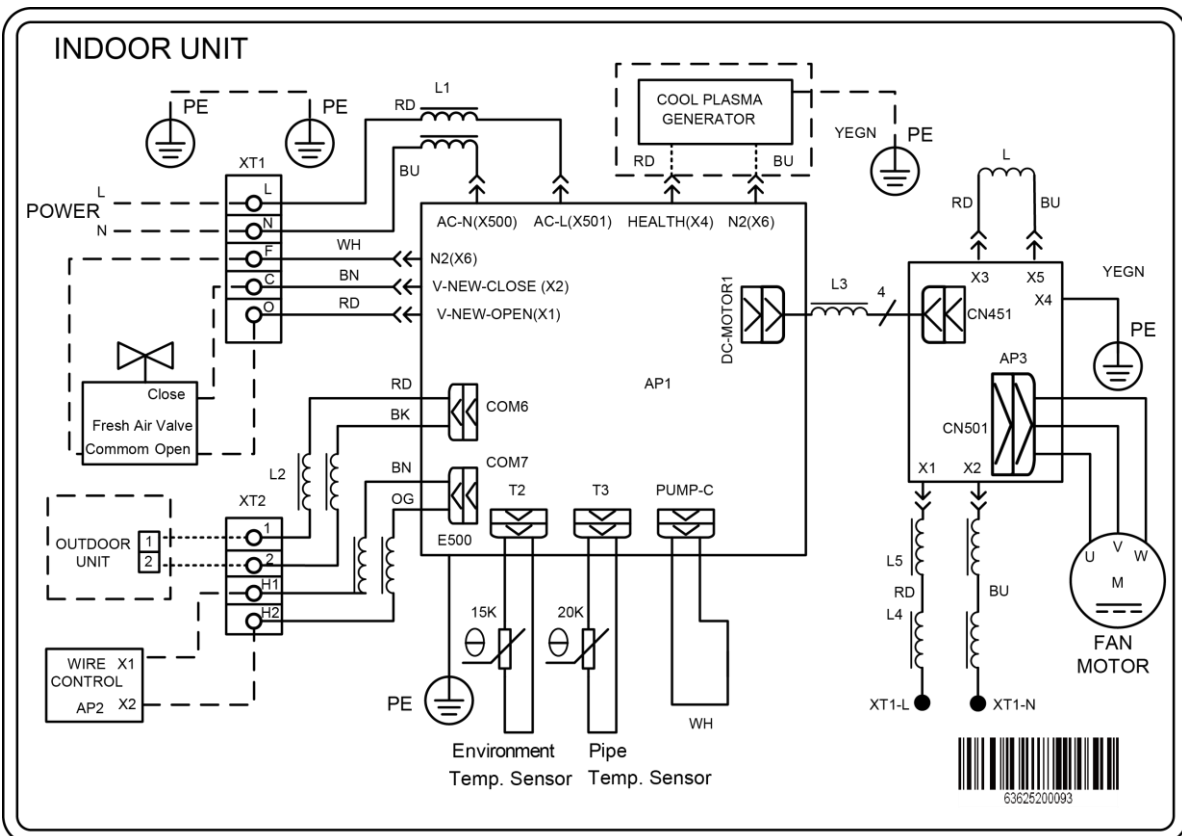

◆ Model: GFH36S3G11/GFH42S3G11/GFH48S3G11/GFH60S3G1

