



# U-MATCH SERIES DC INVERTER AIR CONDITIONERS SERVICE MANUAL

**T1/R410A/50&60Hz  
(GC201602 - I)**

# CONTENTS

<b>PRODUCT</b> .....	<b>2</b>
1 MODELS LIST .....	2
1.1 Outdoor Unit .....	2
1.2 Indoor Unit .....	3
2 NOMENCLATURE .....	4
2.1 Outdoor Unit .....	4
2.2 Indoor Unit .....	4
3 PRODUCT DATA .....	5
3.1 Product Data of Indoor Unit .....	5
3.2 Operation Range .....	11
3.3 Electrical Data .....	11
4 PIPING DIAGRAM .....	12
<b>CONTROL</b> .....	<b>14</b>
1 OPERATION FLOWCHART .....	14
1.1 Cooling/Dry Operation .....	14
1.2 Heating Operation .....	15
2 WIRELESS REMOTE CONTROLLER .....	16
2.1 Operation and Display View .....	16
3 WIRED CONTROLLER .....	18
3.1 Display View .....	18
3.2 Operation View .....	20
4 OPERATION INSTRUCTION OF SPECIAL FUNCTIONS .....	22
4.1 Setting of Filter Clean Reminder Function .....	22
4.2 Low Temperature Drying Function .....	24
4.3 Lock Function .....	24
4.4 Memory Function .....	25
4.5 Door Control Function/Human Sensitive Function .....	25
4.6 Switch between Fahrenheit and Centigrade .....	25
4.7 Enquiry of Ambient Temperature .....	25
4.8 Enquiry of Historical Malfunction .....	26
4.9 Debugging Function .....	26
5 INSTALLATION OF WIRED CONTROLLER .....	29
5.1 Standard Accessories .....	29
5.2 Installation Position and Requirement .....	30
5.3 Installation of Wired Controller .....	30
5.4 Removal of Wired Controller .....	31
6 TROUBLE SHOOTING .....	31
6.1 Display of Error Code .....	31
7 CENTRALIZED CONTROLLER .....	33
7.1 Smart Zone Controller .....	33
7.2 Additional Special Functions .....	36
<b>INSTALLATION</b> .....	<b>51</b>
1 INDOOR UNIT INSTALLATION .....	51
1.1 Installation of Duct Type .....	51
1.2 Installation of Cassette Type .....	60
2 OUTDOOR UNIT INSTALLATION .....	67
2.1 Before Installation .....	67
2.2 Installation Site .....	68
2.3 Caution for Installation .....	68
2.4 Dimension Data .....	69
3 REFRIGERATION PIPING WORK .....	69
3.1 Refrigeration Piping Work Procedures and Caution in Connecting .....	69
3.2 Specification of Connection Pipe .....	74
4 ELECTRIC WIRING WORK .....	74
4.1 Wiring Precautions .....	74
4.2 Electrical Wiring .....	75



<b>MAINTENANCE .....</b>	<b>81</b>
1 TROUBLE TABLE .....	81
2 FLOW CHART OF TROUBLESHOOTING.....	84
2.1 Troubleshooting Flow Chart of Main Control Malfunction .....	84
2.2 Troubleshooting Flow Chart of Drive Malfunction .....	91
2.3 Interface .....	95
2.4 IPM, PFC Testing Method .....	99
3 WIRING DIAGRAM .....	101
3.1 Outdoor unit .....	101
3.2 Indoor unit .....	103
4 DISASSEMBLY AND ASSEMBLY PROCEDURE OF MAIN PARTS.....	106
4.1 Outdoor Unit .....	106
4.2 Indoor Unit.....	109
5 EXPLODED VIEWS AND SPARE PART LIST.....	116
5.1 Outdoor Unit .....	116
5.2 Indoor Unit.....	126

# PRODUCT

# PRODUCT

## 1 MODELS LIST

### 1.1 Outdoor Unit

Model Name	Product Code	Power Supply (V, Ph, Hz)	Appearance
GUHD24NS3GO	CF090W0800	220-240V~ 50/60Hz	
GUHD36NS3GO	CF090W0860	220-240V~ 50/60Hz	
GUHD42NS3GO	CF090W0870	220-240V~ 50/60Hz	
GUHD48NS3GO	CF090W0880	220-240V~ 50/60Hz	
GUHD60NS3GO	CF090W0790	220-240V~ 50/60Hz	

## 1.2 Indoor Unit

Type	Model Name	Product Code	Nominal Capacity Cooling/Heating (kW)	Power Supply (V, Ph, Hz)	Appearance
Duct Type	GFH24S3GI	CF060N0560	7.0/8.0	220-240V~ 50/60Hz	
	GFH24S3G1I	CF060N0561	7.0/8.0		
	GFH36S3GI	CF060N0650	10.0/12.0	220-240V~ 50/60Hz	
	GFH36S3G1I	CF060N0660	10.0/12.0		
	GFH42S3GI	CF060N0670	12.0/13.8	220-240V~ 50/60Hz	
	GFH42S3G1I	CF060N0680	12.0/13.8		
	GFH48S3GI	CF060N0690	13.7/16.0	220-240V~ 50/60Hz	
	GFH48S3G1I	CF060N0700	13.7/16.0		
	GFH60S3GI	CF060N0550	16.0/18.0	220-240V~ 50/60Hz	
	GFH60S3G1I	CF060N0551	16.0/18.0		
Cassette Type	GKH24S3GI	ET010N1160	7.2/8.2	220-240V~ 50/60Hz	
	GKH36S3GI	ET010N1150	10.0/12.0	220-240V~ 50/60Hz	
	GKH42S3GI	ET010N1170	11.5/13.8	220-240V~ 50/60Hz	
	GKH48S3GI	ET010N1180	14.0/16.0	220-240V~ 50/60Hz	

Note: 1 Ton = 12000Btu/h = 3.517kW

**Notes:** The universal outdoor units means that the customer can choose any of three kind of indoor unit to match the outdoor unit without any change with it.

# 2 NOMENCLATURE

## 2.1 Outdoor Unit

G	U	H	D	24	N	S	3	G	O
1	2	3	4	5	6	7	8	9	10

NO.	Description	Options
1	Gree Electric Appliances Inc	Capital Letter :G
2	Unit Type	U=U-Match Outdoor Unit
3	Product Type	C=Cool Only H=Heat Pump without Aux Electric Heaters
4	Compressor Power Supply Type Code	N=Constant Frequency D=DC Inverter A=AC Inverter
5	Nominal Cooling Capacity	Nominal Cooling Capacity =Numberx1000Btu/h
6	Climate Type	N=Climate T1 Condition T= Climate T3 Condition
7	Power Supply Code	S= 220-240V~ 50/60Hz
8	Refrigerant	1 =R22; 2=R407C; 3=R410A
9	Design Code	Design Code: A, B, C, D..... Design Change Code=0 (default) 1,2,3.....
10	Unit Code	O=Outdoor unit

## 2.2 Indoor Unit

G	F	H	24	T	S	3	G	I
1	2	3	4	5	6	7	8	9

NO.	Description	Options
1	Gree Electric Appliances Inc	Capital Letter :G
2	Unit Type	F=Duct Type; K=Cassette Type; T= Floor-ceiling Type
3	Product Type	C=Cool Only H=Heat Pump without Aux Electric Heaters
4	Nominal Cooling Capacity	Nominal Cooling Capacity =Numberx1000Btu/h
5	Climate Type	Omit=Climate T1 Condition T= Climate T3 Condition
6	Power Supply Code	S= 220-240V~ 50/60Hz
7	Refrigerant	1 =R22; 2=R407C; 3=R410A
8	Design Code	Design Code: A, B, C, D..... Design Change Code=0 (default) 1,2,3.....
9	Unit Code	I=indoor unite

# 3 PRODUCT DATA

## 3.1 Product Data of Indoor Unit

### 3.1.1 Duct Type

Model	Indoor unit		GFH24S3GI	GFH24S3G1I
	Outdoor unit		GUHD24NS3GO	GUHD24NS3GO
Nominal Capacity	Cooling	kW	7.00	7.00
		Btu/h	23884	23884
	Heating	kW	8.00	8.00
		Btu/h	27296	27296
Power Input	Cooling	kW	2.18	2.18
	Heating	kW	2.28	2.28
EER/COP		W/W	3.21/3.51	3.21/3.51
Indoor Unit			GFH24S3GI	GFH24S3G1I
Power Supply		-	220-240V~ 50/60Hz	
Heat Exchange		-	Cross Fin Coil	Cross Fin Coil
Fan	Type	-	Centrifugal	Centrifugal
	Drive	-	Direct	Direct
	Motor Output	kW	—	—
	Air Flow	m <sup>3</sup> /h	1500	1500
	Rated Ext. Static Pressure	Pa	50	50
Sound Pressure Level(SS/H/M/L)		dB(A)	46/43/41/38	46/43/41/38
Air Filter		-	PPKZ	
Drain Piping		mm	Φ20×1.2	Φ20×1.2
Dimensions (W×H×D) (Outline/Package)		mm	1225×290×775	1225×290×775
			1338×305×877	1338×305×877
Weight(Net/Gross)		kg	47.0/55.0	47.0/55.0
Outdoor Unit			GUHD24NS3GO	GUHD24NS3GO
Power Supply		-	220-240V~ 50/60Hz	
Heat Exchange		-	Cross Fin Coil	
Fan	Type	-	Axial-flow	
	Fan Motor Speed	rpm	800	800
Compressor	Type	-	Inverter Rotary	Inverter Rotary
	Power Input	W	2550	2550
Refrigerant	Type	-	R410A	
	Control	-	Electronic Expansion Valve	
	Charge	kg	2.2	2.2
Dimensions (W×H×D) (Outline/Package)		mm	1005×790×425	1005×790×425
			1083×855×428	1083×855×428
Weight(Net/Gross)		kg	69.0/74.0	69.0/74.0
Piping Connections	Liquid	Inch	3/8	3/8
	Gas	Inch	5/8	5/8
	Max. Length	m	50	50
	Max. Height	m	15	15



Model	Indoor unit		GFH36S3GI	GFH36S3G1I	GFH42S3GI
	Outdoor unit		GUHD36NS3GO	GUHD36NS3GO	GUHD42NS3GO
Nominal Capacity	Cooling	kW	10.00	10.00	12.00
		Btu/h	34120	34120	40944
	Heating	kW	12.00	12.00	13.80
		Btu/h	40944	40944	47086
Power Input	Cooling	kW	3.10	3.10	3.70
	Heating	kW	3.30	3.30	4.00
EER/COP		W/W	3.23/3.64	3.23/3.64	3.24/3.45
Indoor Unit			GFH36S3GI	GFH36S3G1I	GFH42S3GI
Power Supply		-	220-240V~ 50/60Hz		
Heat Exchange		-	Cross Fin Coil	Cross Fin Coil	Cross Fin Coil
Fan	Type	-	Centrifugal fan	Centrifugal fan	Centrifugal fan
	Drive	-	direct	direct	direct
	Motor Output	kW	—	—	—
	Air Flow	m <sup>3</sup> /h	2000	2000	2200
	Rated Ext. Static Pressure	Pa	50	50	50
Sound Pressure Level(SS/H/M/L)		dB(A)	48/45/43/41	48/45/43/41	50/48/46/43
Air Filter		-	PPKZ		
Drain Piping		mm	Φ20×1.2	Φ20×1.2	Φ20×1.2
Dimensions (W×H×D) (Outline/Package)		mm	1340×350×750	1340×350×750	1340×350×750
			1423×455×837	1423×455×837	1423×455×837
Weight(Net/Gross)		kg	56.0/68.0	56.0/68.0	59.0/71.0
Outdoor Unit			GUHD36NS3GO	GUHD36NS3GO	GUHD42NS3GO
Power Supply		-	220-240V~ 50/60Hz		
Heat Exchange		-	Cross Fin Coil		
Fan	Type	-	Axial fan		
	Fan Motor Speed	rpm	780	780	780
Compressor	Type	-	Inverter Rotary	Inverter Rotary	Inverter Rotary
	Power Input	W	4150	4150	4580
Refrigerant	Type	-	R410A		
	Control	-	Electronic Expansion Valve		
	Charge	kg	3.5	3.5	3.9
Dimensions (W×H×D) (Outline/Package)		mm	1105×1105×440	1105×1105×440	1105×1105×440
			1158×1235×493	1158×1235×493	1158×1235×493
Weight(Net/Gross)		kg	91.0/100.0	91.0/100.0	101.0/111.0
Piping Connections	Liquid	Inch	3/8	3/8	3/8
	Gas	Inch	5/8	5/8	5/8
	Max. Length	m	50	50	50
	Max. Height	m	15	15	30

Model	Indoor unit		GFH42S3G1I	GFH48S3GI	GFH48S3G1I
	Outdoor unit		GUHD42NS3GO	GUHD48NS3GO	GUHD48NS3GO
Nominal Capacity	Cooling	kW	12.0	13.7	13.7
		Btu/h	40944	46744	47768
	Heating	kW	13.8	16.0	16.0
		Btu/h	47086	54592	54592
Power Input	Cooling	kW	3.70	4.25	4.25
	Heating	kW	4.00	4.80	4.80
EER/COP		W/W	3.24/3.45	3.22/3.33	3.22/3.33
Indoor Unit			GFH42S3G1I	GFH48S3GI	GFH48S3G1I
Power Supply		-	220-240V~ 50/60Hz		
Heat Exchange		-	Cross Fin Coil		
Fan	Type	-	Centrifugal fan		
	Drive	-	direct		
	Motor Output	kW	—		
	Air Flow	m <sup>3</sup> /h	2200	2500	2500
	Rated Ext. Static Pressure	Pa	50	50	50
Sound Pressure Level(SS/H/M/L)		dB(A)	50/48/46/43	51/48/46/44	51/48/46/44
Air Filter		-	PPKZ		
Drain Piping		mm	Φ20×1.2	Φ20×1.2	Φ20×1.2
Dimensions (W×H×D) (Outline/Package)		mm	1340×350×750	1340×350×750	1340×350×750
			1423×455×837	1423×455×837	1423×455×837
Weight(Net/Gross)		kg	59.0/71.0	59.0/71.0	59.0/71.0
Outdoor Unit			GUHD42NS3GO	GUHD48NS3GO	GUHD48NS3GO
Power Supply		-	220-240V~50/60Hz	220-240V~ 50/60Hz	220-240V~50/60Hz
Heat Exchange		-	Cross Fin Coil	Cross Fin Coil	Cross Fin Coil
Fan	Type	-	Axial fan	Axial fan	Axial fan
	Fan Motor Speed	rpm	780	800	800
Compressor	Type	-	Inverter Rotary	Inverter Rotary	Inverter Rotary
	Power Input	W	4580	4580	4580
Refrigerant	Type	-	R410A	R410A	R410A
	Control	-	Electronic Expansion Valve		
	Charge	kg	3.9	4.0	4.0
Dimensions (W×H×D) (Outline/Package)		mm	1105×1105×440	1085×1365×425	1085×1365×425
			1158×1235×493	1143×1505×478	1143×1505×478
Weight(Net/Gross)		kg	101.0/111.0	117.0/128.0	117.0/128.0
Piping Connections	Liquid	Inch	3/8	3/8	3/8
	Gas	Inch	5/8	5/8	5/8
	Max. Length	m	50	50	50
	Max. Height	m	30	30	30

Model	Indoor unit		GFH60S3GI	GFH60S3G1I
	Outdoor unit		GUHD60NS3GO	GUHD60NS3GO
Nominal Capacity	Cooling	kW	16.0	16.0
		Btu/h	54592	54592
	Heating	kW	18.0	18.0
		Btu/h	61416	61416
Power Input	Cooling	kW	5.00	5.00
	Heating	kW	5.00	5.00
EER/COP		W/W	3.20/3.60	3.20/3.60
Indoor Unit			GFH60S3GI	GFH60S3G1I
Power Supply		-	220-240V~ 50/60Hz	
Heat Exchange		-	Cross Fin Coil	
Fan	Type	-	Centrifugal	
	Drive	-	direct	
	Motor Output	kW	-	
	Air Flow	m <sup>3</sup> /h	3100	3100
	Rated Ext. Static Pressure	Pa	50	50
Sound Pressure Level(SS/H/M/L)		dB(A)	55/53/51/48	55/53/51/48
Air Filter		-	PPKZ	
Drain Piping		mm	Φ30×1.5	Φ30×1.5
Dimensions (W×H×D) (Outline/Package)		mm	1500×390×800	1500×390×800
			1578×470×883	1578×470×883
Weight(Net/Gross)		kg	79.0/103.0	79.0/103.0
Outdoor Unit			GUHD60NS3GO	GUHD60NS3GO
Power Supply		-	220-240V~ 50/60Hz	
Heat Exchange		-	Cross Fin Coil	
Fan	Type	-	Axial-flow	
	Fan Motor Speed	rpm	800	800
Compressor	Type	-	Inverter Rotary	
	Power Input	W	4580	4580
Refrigerant	Type	-	R410A	
	Control	-	Electronic expansion valve	
	Charge	kg	5.5	5.5
Dimensions (W×H×D) (Outline/Package)		mm	1085×1365×425	1085×1365×425
			1143×1505×478	1143×1505×478
Weight(Net/Gross)		kg	121.0/133.0	121.0/133.0
Piping Connections	Liquid	Inch	3/8	3/8
	Gas	Inch	3/4	3/4
	Max. Length	m	50	50
	Max. Height	m	30	30

### 3.1.2 Cassette Type

Model	Indoor unit		GKH24S3GI	GKH36S3GI
	Outdoor unit		GUHD24NS3GO	GUHD36NS3GO
Nominal Capacity	Cooling	kW	7.20	10.00
		Btu/h	24566	34120
	Heating	kW	8.20	12.00
		Btu/h	27978	40944
Power Input	Cooling	kW	2.15	3.00
	Heating	kW	2.45	3.50
EER/COP		W/W	3.34/3.34	3.34/3.43
Indoor Unit			GKH24S3GI	GKH36S3GI
Power Supply		-	220-240V~ 50/60Hz	
Heat Exchange		-	Cross Fin Coil	Cross Fin Coil
Fan	Type	-	Centrifugal	Centrifugal
	Drive	-	Direct	Direct
	Motor Output	kW	—	—
	Air Flow	m <sup>3</sup> /h	1400	1900
	Rated Ext. Static Pressure	Pa	0	0
Sound Pressure Level(SS/H/M/L)		dB(A)	50/48/45/43	54/53/52/50
Air Filter		-	PPKZ	
Drain Piping		mm	Φ31.5×2.3	Φ31.5×2.3
Dimensions (W×H×D) (Outline/Package)		mm	840×840×240	840×840×290
			963×963×325	963×963×379
Weight(Net/Gross)		kg	29.0/37.0	33.0/41.0
Outdoor Unit			GUHD24NS3GO	GUHD36NS3GO
Power Supply		-	220-240V~ 50/60Hz	
Heat Exchange		-	Cross Fin Coil	
Fan	Type	-	Axial-flow	
	Fan Motor Speed	rpm	800	800
Compressor	Type	-	Inverter Rotary	Inverter Rotary
	Power Input	W	2550	4150
Refrigerant	Type	-	R410A	
	Control	-	Electronic Expansion Valve	
	Charge	kg	2.2	3.5
Dimensions (W×H×D) (Outline/Package)		mm	1005×790×425	1105×1105×440
			1083×855×428	1158×1235×493
Weight(Net/Gross)		kg	69.0/74.0	91.0/100.0
Piping Connections	Liquid	Inch	3/8	3/8
	Gas	Inch	5/8	5/8
	Max. Length	m	50	50
	Max. Height	m	15	15

Model	Indoor unit		GKH42S3GI	GKH48S3GI
	Outdoor unit		GUHD42NS3GO	GUHD48NS3GO
Nominal Capacity	Cooling	kW	11.50	14.00
		Btu/h	39238	47768
	Heating	kW	13.80	16.00
		Btu/h	47086	54592
Power Input	Cooling	kW	3.50	4.30
	Heating	kW	4.20	4.50
EER/COP		W/W	3.28/3.28	3.25/3.55
Indoor Unit			GKH42S3GI	GKH48S3GI
Power Supply		-	220-240V~ 50/60Hz	
Heat Exchange		-	Cross Fin Coil	Cross Fin Coil
Fan	Type	-	Centrifugal	Centrifugal
	Drive	-	Direct	Direct
	Motor Output	kW	—	—
	Air Flow	m <sup>3</sup> /h	2000	2300
	Rated Ext. Static Pressure	Pa	0	0
Sound Pressure Level(SS/H/M/L)		dB(A)	53/52/50/47	55/53/50/47
Air Filter		-	PPKZ	
Drain Piping		mm	Φ31.5×2.3	Φ31.5×2.3
Dimensions (W×H×D) (Outline/Package)		mm	840×840×290	910×910×290
			963×963×379	1023×993×375
Weight(Net/Gross)		kg	34.0/42.0	43.0/53.0
Outdoor Unit			GUHD42NS3GO	GUHD48NS3GO
Power Supply		-	220-240V~ 50/60Hz	
Heat Exchange		-	Cross Fin Coil	
Fan	Type	-	Axial-flow	
	Fan Motor Speed	rpm	800	800
Compressor	Type	-	Inverter Rotary	Inverter Rotary
	Power Input	W	4580	4580
Refrigerant	Type	-	R410A	
	Control	-	Electronic Expansion Valve	
	Charge	kg	3.9	4.0
Dimensions (W×H×D) (Outline/Package)		mm	1105×1105×440	1085×1365×425
			1158×1235×493	1143×1505×478
Weight(Net/Gross)		kg	101.0/111.0	117.0/128.0
Piping Connections	Liquid	Inch	3/8	3/8
	Gas	Inch	5/8	5/8
	Max. Length	m	50	50
	Max. Height	m	30	30

Note: Nominal capacities are based on the follow conditions.

Mode	Indoor °C (°F)	Outdoor °C (°F)
Cooling	DB:27(80.6) WB:19(66.2)	DB:35(95.0) WB:24(75.2)
Heating	DB:20(68.0) WB:--(--)	DB:7(44.6) WB:6(42.8)
Piping Length	24-60k	7.5m

The air volume is measured at the relevant standard external static pressure.

Noise is tested in the semianechoic room, so it should be slightly higher in the actual operation due to environmental change.

## 3.2 Operation Range

Mode	Range of Outdoor Temperature °C
Cooling	-15-48
Heating	-10-24

## 3.3 Electrical Data

### 3.3.1 Outdoor unit

Table 1-4-1 Electrical Data of Outdoor Unit

Model	Compressor			Fan Motor	Fuse/Breaker Capacity	Min. Power Supply Cord
	Power Supply	Qty.	RLA	FLA		
	V/Ph/Hz	-	A	A	A	mm <sup>2</sup>
GUHD24NS3GO	220-240,1,50/60	1	11.5	-	20	2.5
GUHD36NS3GO	220-240,1,50/60	1	19.0	-	20	4.0
GUHD42NS3GO	220-240,1,50/60	1	21.0	-	25	4.0
GUHD48NS3GO	220-240,1,50/60	1	21.0	-	40	6.0
GUHD60NS3GO	220-240,1,50/60	1	21.0	-	40	6.0

### 3.3.2 Indoor unit

Table 1-4-2 Electrical Data of Indoor Unit

Model	Power Supply	Fan Motor FLA	Fuse/Breaker Capacity	Min. Power Supply Cord
	V/Ph/Hz	A	A	mm <sup>2</sup>
GFH24S3GI	220-240,1,50/60	<1	5/6	1.0
GFH24S3G1I	220-240,1,50/60	<1	5/6	1.0
GFH36S3GI	220-240,1,50/60	<1	5/6	1.0
GFH36S3G1I	220-240,1,50/60	<1	5/6	1.0
GFH42S3GI	220-240,1,50/60	<1	5/6	1.0
GFH42S3G1I	220-240,1,50/60	<1	5/6	1.0
GFH48S3GI	220-240,1,50/60	<1	5/6	1.0
GFH48S3G1I	220-240,1,50/60	<1	5/6	1.0
GFH60S3GI	220-240,1,50/60	<1	5/6	1.0
GFH60S3G1I	220-240,1,50/60	<1	5/6	1.0
GKH24S3GI	220-240,1,50/60	<1	5/6	1.0
GKH36S3GI	220-240,1,50/60	<1	5/6	1.0
GKH42S3GI	220-240,1,50/60	<1	5/6	1.0
GKH48S3GI	220-240,1,50/60	<1	5/6	1.0

#### Notes:

RLA: Rated load amperes

LRA: Locked rotor amperes

FLA: Full load current

- ①. Install the disconnect device with a contact gap of at least 3mm in all poles nearby the units (Both indoor unit and outdoor unit).The appliance must be positioned so that the plug is accessible.

- ②. The specifications of the breaker and power cable listed in the table above are determined based on the maximum power (maximum amps) of the unit.
- ③. The specifications of the power cable listed in the table above are applied to the conduit-guarded multi-wire copper cable (like, YJV copper cable, consisting of PE insulated wires and a PVC cable jacket) used at 40°C and resistible to 90°C. If the working condition changes, they should be modified according to the related national standard.
- ④. The specifications of the breaker listed in the table above are applied to the breaker with the working temperature at 40°C. If the working condition changes, they should be modified according to the related national standard.

## 4 PIPING DIAGRAM

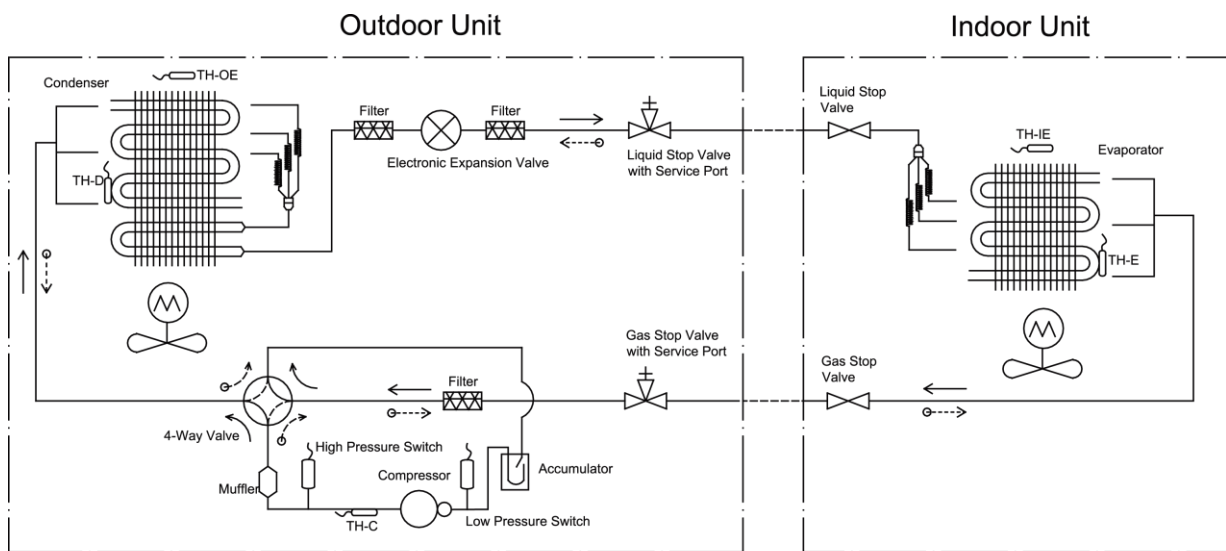

TH-OE Outdoor Environment Thermal Bulb  
 TH-C Outdoor Condenser Thermal Bulb  
 TH-D Compressor Discharge Thermal Bulb

← Cooling  
 ○---> Heating

TH-IE Indoor Environment Thermal Bulb  
 TH-E Indoor Evaporator Thermal Bulb

**Note:**

1. it is just a schematic diagram and some parts may differ from the real objects inside the unit.
2. The throttling device for units 09K and 12K is the capillary rather than the electronic expansion valve.

# CONTROL



# CONTROL

## 1 OPERATION FLOWCHART

### 1.1 Cooling/Dry Operation

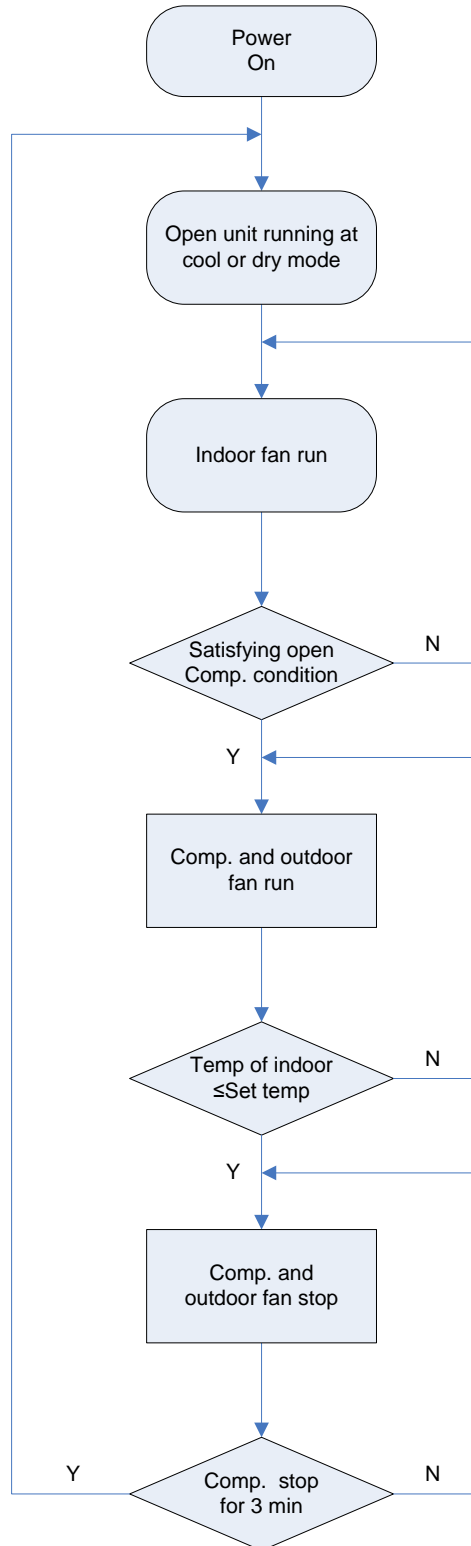

## 1.2 Heating Operation

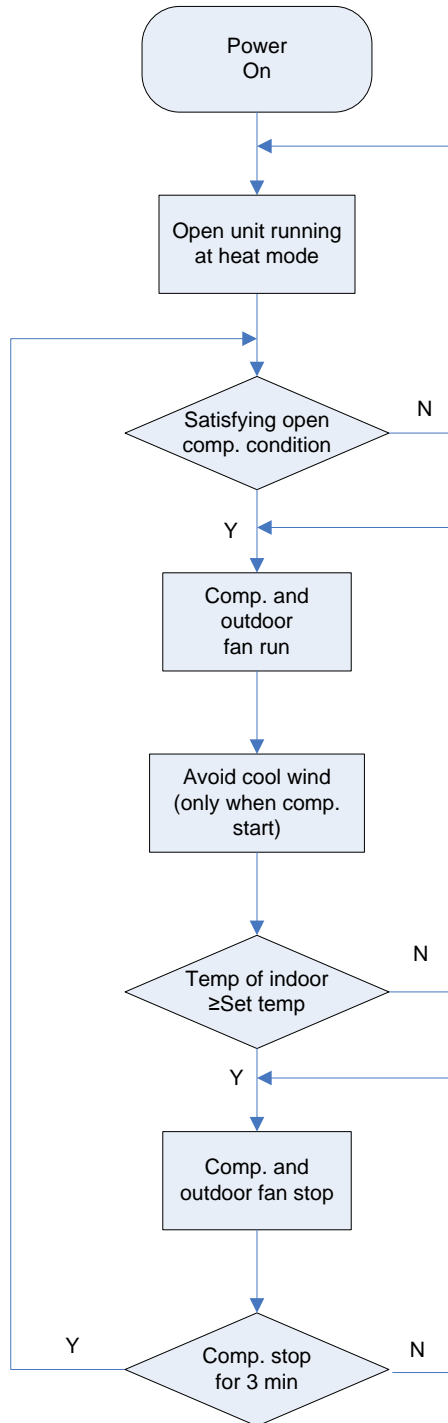

# 2 WIRELESS REMOTE CONTROLLER

## 2.1 Operation and Display View

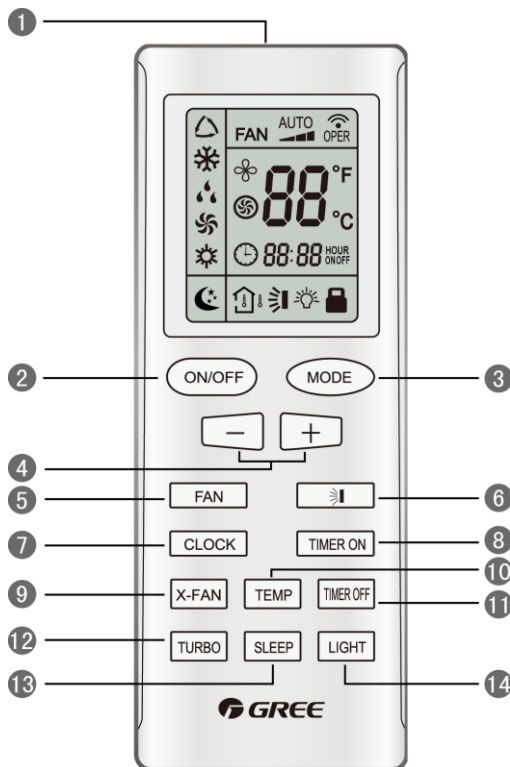
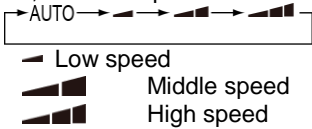
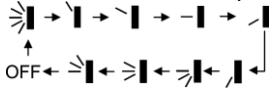















Table 2-2-1 Operation instruction of wireless remote controller

No.	Name	Function Description
1	Signal transmitter	<ul style="list-style-type: none"> <li>● Signal transmitter</li> </ul>
2	ON/OFF button	<ul style="list-style-type: none"> <li>● Press this button and the unit will be turned on; press it once more, and the unit will be turned off. When turning off the unit, the Sleep function will be canceled, but the presetting time is still remained.</li> </ul>
3	MODE button	<ul style="list-style-type: none"> <li>● By pressing this button, Auto, Cool, Dry, Fan, Heat mode can be selected circularly. Auto mode is default after power on. Under the Auto mode, the setting temperature will not be displayed; Under the Heat mode, the initial value is 28°C (82°F); Under other modes, the initial value is 25°C(77°F).</li> </ul> <p>△ AUTO; ❄️ COOL; 💧 DRY; 🌀 FAN; ☀️ HEAT (only for cooling and heating unit)</p>
4	- button	<ul style="list-style-type: none"> <li>● Preset temperature can be decreased by pressing this button. Pressing and holding this button for more than 2 seconds can make the temperature changed quickly until release this button and then transmit this order. The temperature adjustment is unavailable under the Auto mode, but the order can be sent by pressing this button. Centigrade setting range: 16-30; Fahrenheit scale setting range 61-86.</li> </ul>
	+ button	<ul style="list-style-type: none"> <li>● Preset temperature can be increased by pressing this button. Pressing and holding this button for more than 2 seconds can make the temperature changed quickly until release the button and then transmit this order. The temperature adjustment is unavailable under the Auto mode, but the order can be sent by pressing this button. Centigrade setting range: 16-30; Fahrenheit scale setting range 61-86.</li> </ul>

5	FAN button	<ul style="list-style-type: none"> <li>● By pressing this button, Auto, Low, Middle, High speed can be circularly selected. After power on, Auto fan speed is default.</li> <li>●  <ul style="list-style-type: none"> <li>— Low speed</li> <li>▴ Middle speed</li> <li>▴▴ High speed</li> </ul> </li> </ul> <p><b>Note:</b> Under the DRY mode, the fan will be kept running at the low speed and the fan speed isn't adjustable.</p>
6	SWING UP/DOWN button	<ul style="list-style-type: none"> <li>● Press this button to set up the swing angle, which circularly changes as below:  </li> <li>● When the guide louver starts to swing up and down, if SWING functions is canceled, the air guide louver will stop and remains at the current position.   indicates the guide louver swings up and down among those five directions.(Simplified SWING function applicable for some Fan Coil Units: When the wireless remote controller is energized initially with the unit under the OFF status, it should be set by pressing the + button and the SWING button simultaneously, with the symbol  blinking twice. Then, after the unit is turned on, this function can be activated by pressing the SWING button, with the displayed symbol  indicating swing function is on and without this displayed symbol indicating swing function is off.)</li> </ul>
7	CLOCK button	<ul style="list-style-type: none"> <li>● By pressing this button, the clock is allowed to be set, with  blinking, and then press the +/- button to adjust the clock within 5 seconds. If the +/--button is pressed down constantly for more than 2 seconds, the clock setting will be increased or decreased 10 minutes every 0.5 seconds. After that, another press on the CLOCK button accepts the setting. 12:00 is the default, when the wireless remote controller is energized.</li> </ul>
8	TIMER ON button	<ul style="list-style-type: none"> <li>● When TIMER ON is activated, ON will blink while the symbol  will disappear. Within 5 seconds it is allowed to set the ON time by pressing the +/- button. Each press will make the time increase or decrease one minute. Besides, the time can also be set by pressing the +/- button constantly. that is, in the early 2.5 seconds, the time will increase/decrease quickly per single minute, and in the late 2.5, the time will increase/decrease per ten minutes. After the desired time value is set, press TIENE ON again to conform the setting within five seconds. After that, another press on TIMER ON will cancel the setting. Prior to this setting, the clock shall be set to the actual time.</li> </ul>
9	X-FAN button	<ul style="list-style-type: none"> <li>● Pressing this button can activate or deactivate the X-FAN function. In Cool or Dry mode, by pressing this button, if "" is displayed, it indicates the X-FAN function is activated. By repressing this button, if "" disappears, it indicates the X-FAN function is deactivated. After energization, X-FAN OFF is defaulted. If the unit is turned off, X-FAN can be deactivated but can't be activated.</li> </ul>
10	TEMP button	<ul style="list-style-type: none"> <li>● By pressing this button it is allowed to select displaying the indoor setting temperature or the indoor ambient temperature.</li> <li>● Indoor setting temperature is default after the indoor unit is energized initially.</li> <li>● By pressing the TEMP button, when the temperature symbol  is displayed, the indoor displayer will show the indoor setting temperature; when  is displayed, it will show the indoor ambient temperature; when  is invalidation, If current displays indoor ambient temperature, if received the other remote control signal, it will display presetting temperature, 5s later, will back to display the ambient temperature. (This function is applicable to partial of models)</li> </ul>
11	TIMER OFF button	<ul style="list-style-type: none"> <li>● By pressing this button it is available to go to the TIMER OFF setting state with the same setting method as that of the TIMER ON, in which case the OFF symbol blinks.</li> </ul>
12	TURBO button	<ul style="list-style-type: none"> <li>● In the Cool or Heat mode, pressing this button can activate or deactivate the TURBO function. When the TURBO function is activated, its symbol  will be displayed; when the running mode or the fan speed is changed, this function will be canceled automatically. (This function is applicable to partial of models).</li> </ul>
13	SLEEP button	<ul style="list-style-type: none"> <li>● By pressing this button, Sleep On and Sleep Off can be selected. After powered on, Sleep Off is defaulted. Once the unit is turned off, the Sleep function is canceled. When Sleep is set to On, the symbol of SLEEP  will display. Under the Fan and Auto modes, this function is not available.</li> </ul>
14	LIGHT button	<ul style="list-style-type: none"> <li>● Press this button to select LIGHT on or off in the displayer. When the LIGHT is set to on, the icon  will be displayed and the indicating light in the displayer will be on. When the LIGHT is set to off, the icon  will be disappeared and the indicating light in the displayer will be off.</li> </ul>

# 3 WIRED CONTROLLER

## 3.1 Display View

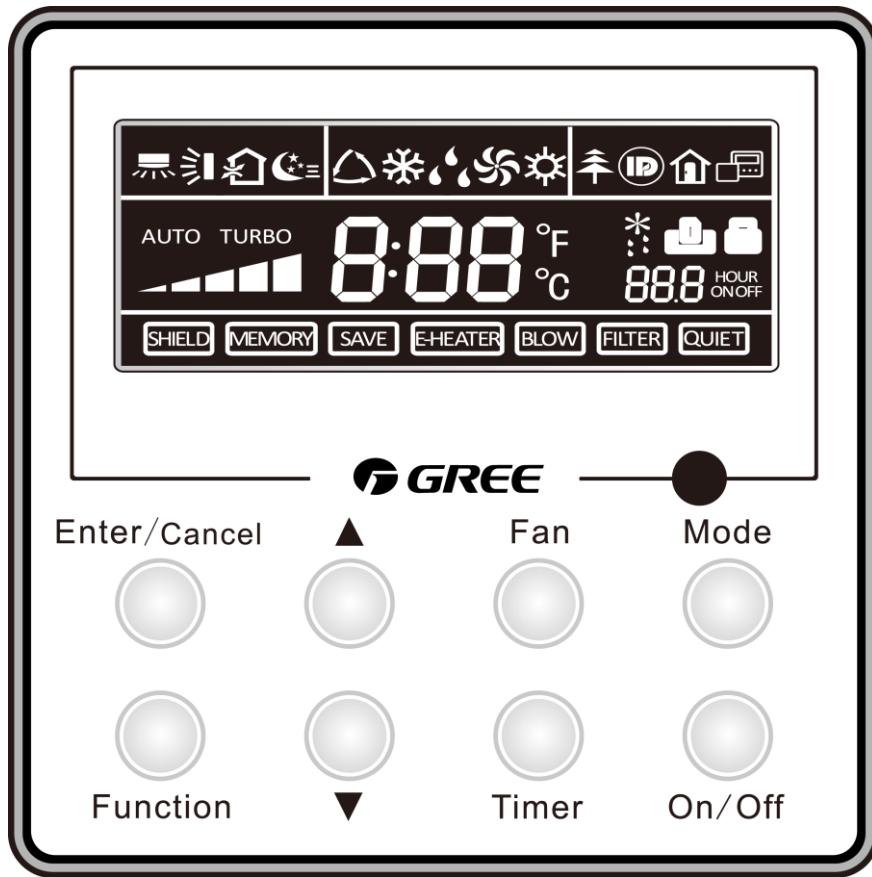

Figure 2-3-1 Appearance of wired controller

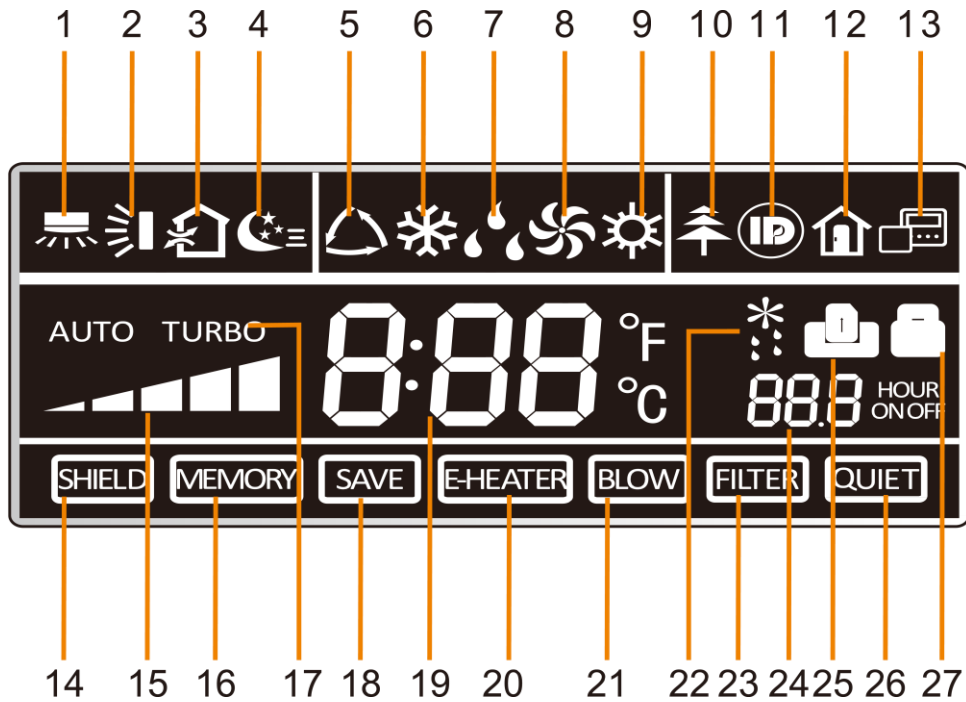





























Figure 2-3-2 LCD display of wired controller

Table 2-3-1 Instruction to LCD Display

No.	Icons	Introduction
1		Left and right swing function
2		Up and down swing function
3		Air exchange function
4		Sleep function
5		Auto mode
6		COOL mode
7		DRY mode
8		FAN mode
9		HEAT mode
10		Health function
11		I-Demand function
12		Vacation function
13		Status display of master and slave wired controller
14		Shield function The button operation, temperature setting, "On/Off" operation, "Mode" setting, and "Save" setting are disabled.
15		Fan speed
16		Memory function The unit will resume the original setting state after power recovery.
17		Turbo function
18		Energy-saving function
19		Ambient/setting temperature
20		Electric heater
21		Blow function
22		Defrosting function
23		Filter cleaning
24		Timer Setting
25		Keycard control / Detected status sensed by human body
26		Quiet function
27		Lock function

## 3.2 Operation View

### 3.2.1 Silk Screen of Buttons

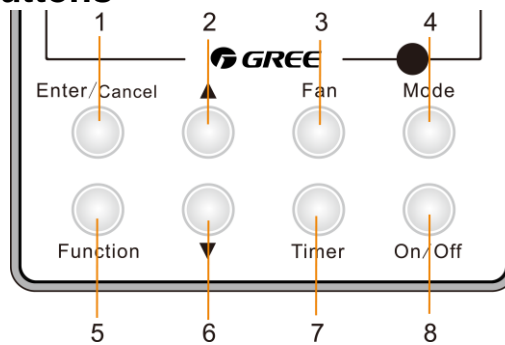

Figure 2-3-3 Silk screen of buttons

### 3.3.2 Instruction to Function of Buttons

Table 2-3-2 Instruction to buttons of wired controller

No.	Description	Functions
1	Enter/Cancel	(1) Function selection and canceling; (2) Press it for 5s to view the ambient temperature; press Mode button to select viewing outdoor ambient temperature or indoor ambient temperature.
2	▲	(1) Running temperature setting range of indoor unit: 16-30℃; (2) Timer setting range: 0.5-24hr;
6	▼	(3) Setting of air function level; (4) Setting of energy-saving temperature; (5) Setting of cleaning class.
3	Fan	Setting of high/medium high/medium/medium low/low/auto fan speed.
4	Mode	Setting of auto/cooling/heating/fan/dry mode of indoor unit.
5	Function	Switch over among these functions of swing/ air/ sleep/ health/ I-Demand/ out/turbo/ save/ e-heater/ X-fan/ clean/ quiet.
7	Timer	Timer setting.
8	On/Off	Turn on/off indoor unit.
4 Mode and 2 ▲	Memory function	Press Mode and ▲ buttons at the same time for 5s under off state of the unit to enter/cancel memory function (If memory function is set, indoor unit will resume original setting state after power failure and then power recovery. If not, indoor unit is defaulted to be off after power recovery. Ex-factory setting of memory function is on).
2 ▲ and 6 ▼	Lock	Upon startup of the unit without malfunction or under off state of the unit, press ▲ and ▼ buttons at the same time for 5s to enter lock state. In this case, any other buttons won't respond when pressing. Repress ▲ and ▼ buttons for 5s to quit lock state.
4 Mode and 5 Function	Enquiry and setting of address of wired controller	Under off state of the unit, press Mode and Function buttons at the same time for 5s to set the address. (More details please refer to project debugging)
5 Function and 7 Timer	Setting of project parameters (More details please refer to the Notes)	Under off state of the unit, press Function and Timer buttons at the same time for 5s to go to the debugging menu. Press Mode button to adjust the setting items and press ▲ or ▼ buttons to set the actual value.
4 Mode and 6 ▼	Switch between Fahrenheit and Centigrade	Under off state of the unit, press Mode and ▼ buttons at the same time for 5s to switch between Fahrenheit and Centigrade.
5 Function and 6 ▼	Viewing historical malfunction	Continuously press Function and ▼ buttons for 5s to view historical malfunction. Then press ▲ and ▼ buttons to adjust displayed contents. The timer displaying position displays the sequence of malfunction and the detailed error code. The 5th displayed malfunction is the last malfunction.
1 Enter/Cancel and 4 Mode	Setting of master and slave wired controller	Under off state of the unit, press Enter/Cancel and Mode buttons at the same time for 5s to set master and slave wired controller. Press ▲ or ▼ button to adjust. (More details please refer to project debugging)

**Notes:**

The following functions can be set through Function and Timer buttons: setting of ambient temperature sensor, selecting three speeds in high speed and three speeds in low speed of indoor fan motor, display setting of freeze protection error code, setting of cold air prevention and hot air hot prevention function, setting of refrigerant-lacking protection function, selecting of blowing residual heat of indoor unit, selecting of compressor electric heater mode, selecting of low-power consumption mode, selecting door control function, selecting human sensitive function, long-distance monitoring, temperature compensation value at the air return port.

**3.2.3 Setting of Wired Controller's Address****3.2.3.1 Enquiry and Setting of Wired Controller's Address**

Under off state of the unit, press Function and Mode buttons at the same time for 5s to enter setting interface of wired controller's address. In this case, LCD displays address number. Then press▲ or ▼ button to adjust address and then Press Enter/Cancel button to confirm. The address setting is related to the setting of Debugging Function 4.9.10. When the selection in 4.9.10 is 00, address of centralized controller is to be set and the address setting range is 01~16; when the selection in 4.9.10 is 01, address of long-distance monitor is to be set and the address setting range is 01~255.

Enquiry and setting of wired controller's address is shown as Figure 2-3-4 below:

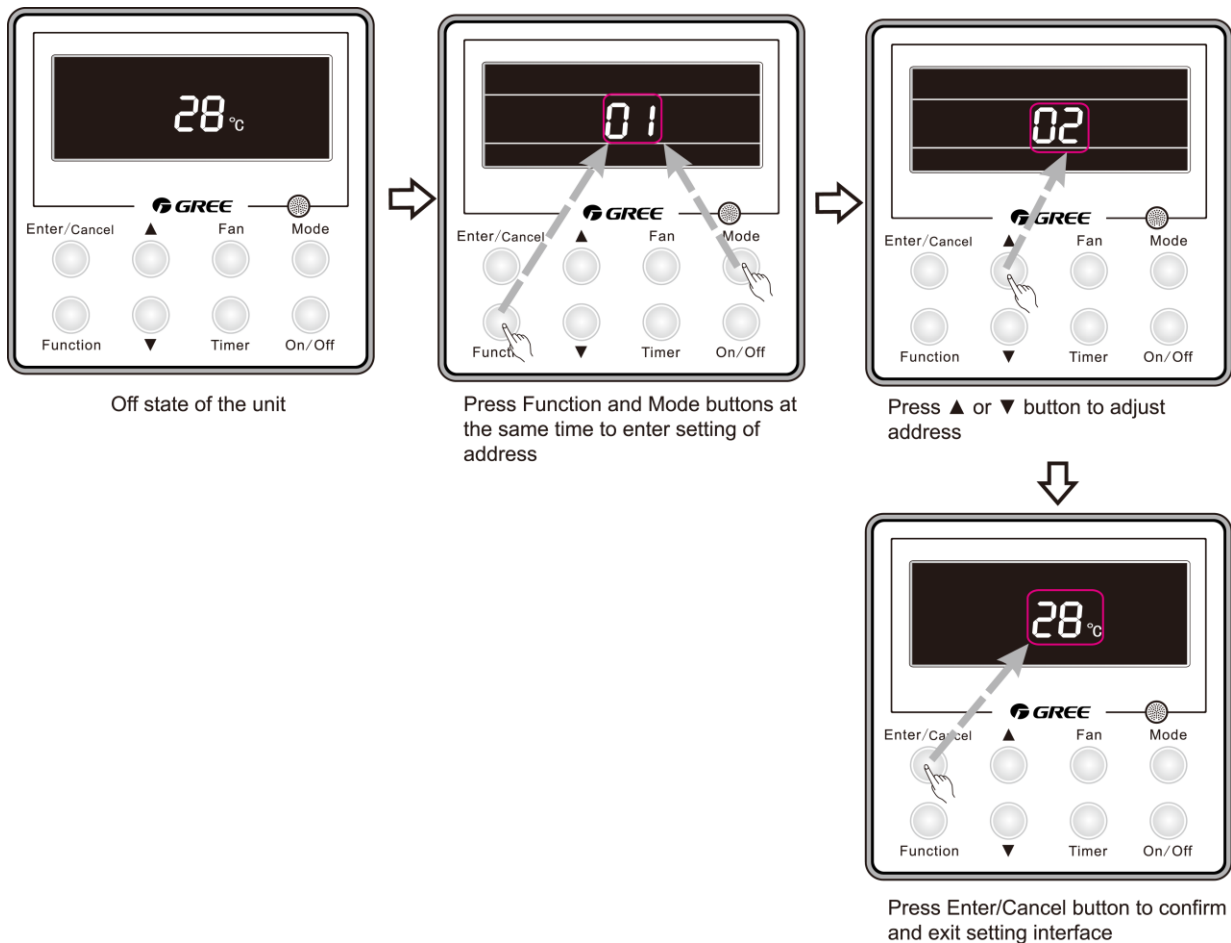



Figure 2-3-4 Enquiry and setting of wired controller's address

**3.2.3.2 Setting of Master/Slave Wired Controller's Address**

Under off status of the unit, press Enter/Cancel and Mode buttons at the same time for 5s to go to



the enquiry and setting interface of master/slave wired controller. In this case, LCD displays wired controller's address (01 for master wired controller and 02 for slave wired controller). Press ▲ or ▼ button to adjust address of master/slave wired controller and then press Enter/Cancel button to confirm. If slave wired controller is set, the icon  will be displayed.

**Note:** If there is only one wired controller, it only can be set as the master; If there are two wired controllers, one should be the master and the other should be the slave.

Setting of master/slave wired controller's address is shown as Figure 2-3-5 below:

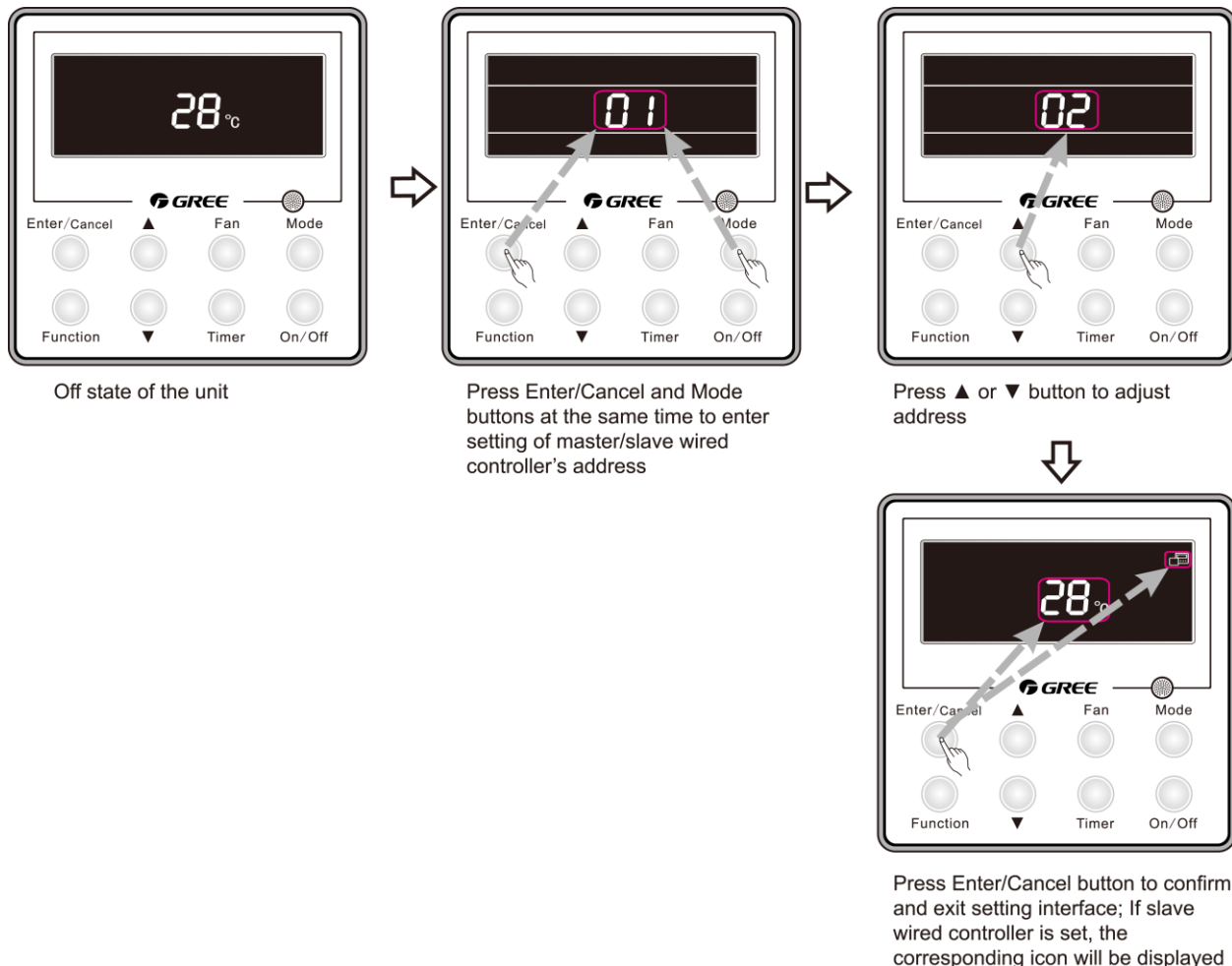



Figure 2-3-5 Enquiry and setting of master/slave wired controller's address

## 4 OPERATION INSTRUCTION OF SPECIAL FUNCTIONS

### 4.1 Setting of Filter Clean Reminder Function

When unit is on, press Function button to switch to filter clean reminder function. The  icon will blink and then enter setting of filter clean reminder function. Timer zone displays the set pollution level and you can press ▲ or ▼ button to adjust the level. Then press Enter/Cancel button to turn on this function.

When filter clean reminder function is turned on, press Function button to switch to filter clean reminder function. The  icon will blink and press ▲ or ▼ button to adjust timer zone to display "00". Then press Enter/Cancel button to cancel this function.

Setting of filter clean reminder function is shown as Figure 2-4-1 below:

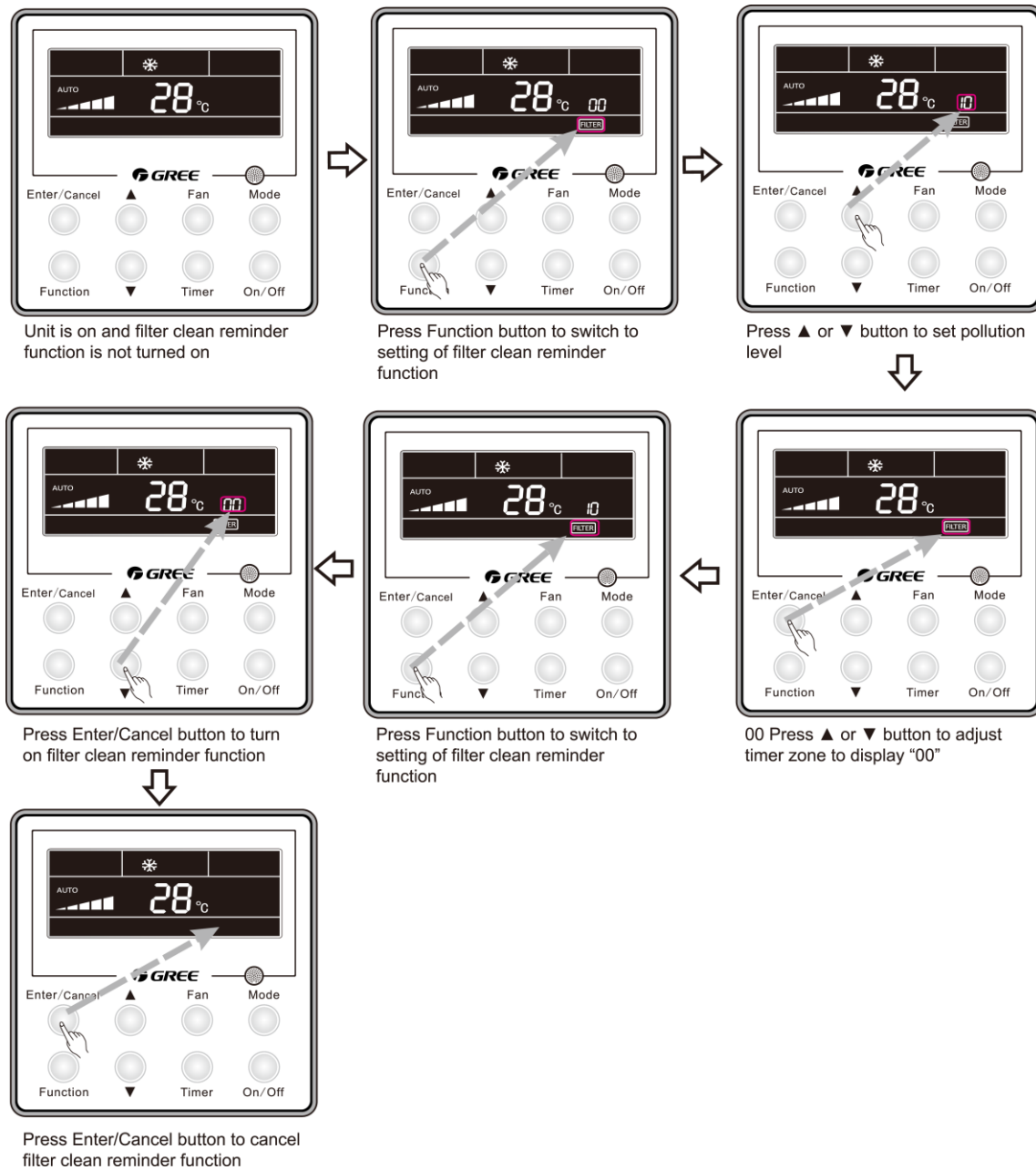

Figure 2-4-1 Setting of filter clean reminder function

When setting the filter clean reminder function, timer zone will display 2 digits, of which the former indicates the pollution degree of operating place and the latter indicates the accumulated operating time of indoor unit. There are 4 types of situations:

(1) Clean Reminder is off (Timer zone shows "00").

(2) Slight pollution: the former digit in timer zone shows 1 while the latter one shows 0, which indicates the accumulated operating time is 5500hr. Each time the latter digit increases 1, the accumulated operating time increases 500hr. When it reaches 9, it means the accumulated operating time is 10000hr.

(3) Medium pollution: the former digit in timer zone shows 2 while the latter one shows 0, which

indicates the accumulated operating time is 1400hr. Each time the latter digit increases 1, the accumulated operating time increases 400hr. When it reaches 9, it means the accumulated operating time is 5000hr.

(4) Heavy pollution: the former digit in timer zone shows 3 while the latter one shows 0, which indicates the accumulated operating time is 100hr. Each time the latter digit increases 1, the accumulated operating time increases 100hr. When it reaches 9, it means the accumulated operating time is 1000hr.



The detailed pollution level and the corresponding time is as shown in Table 2-4-1 below:

Table 2-4-1 Pollution level and corresponding time

Pollution level	Accumulated operating time (hour)	Pollution level	Accumulated operating time (hour)	Pollution level	Accumulated operating time (hour)
10	5500	20	1400	30	100
11	6000	21	1800	31	200
12	6500	22	2200	32	300
13	7000	23	2600	33	400
14	7500	24	3000	34	500
15	8000	25	3400	35	600
16	8500	26	3800	36	700
17	9000	27	4200	37	800
18	9500	28	4600	38	900
19	10000	29	5000	39	1000

If filter clean reminder function is turned on, the  icon will be on.

(1) If cleaning time is not reached, no matter the setting is changed or not, the accumulated operating time won't be recalculated when pressing Enter/Cancel button;

(2) If cleaning time is reached, in unit on or off state,  will blink every 0.5s for reminder. Press Function button to switch to  icon and press ▲ and ▼ button to adjust the level. Then press Enter/Cancel button, so the accumulated operating time won't be cleared (If the adjusted level is higher than the present accumulated operating time, the icon won't blink any more; if the adjusted level is lower than the present accumulated operating time, the icon will go on blinking).

(3) The only way to cancel filter clean reminder function is to press Function button to switch to filter clean reminder function. The  icon will blink and press ▲ or ▼ button to adjust timer zone to display "00". In this case, the accumulated operating time will be cleared.

## 4.2 Low Temperature Drying Function

Under dry mode and when set temperature is 16°C, continuously press ▼ button for twice and then the set temperature will be 12°C. In this case, the unit will enter low temperature drying function.

When low temperature drying function is turned on, press ▲ button or Mode button to exit low temperature drying function.

## 4.3 Lock Function

When unit is turned on normally or turned off, pressing ▲ and ▼ buttons at the same time for 5s will

turn on Lock function. LCD will display . Pressing ▲ and ▼ buttons at the same time for 5s to turn off this function.

When Lock function is turned on, any other buttons won't respond when pressing. The function can be memorized after power failure and then power recovery.

#### 4.4 Memory Function

Press Mode and ▲ buttons at the same time for 5s under off state of the unit to turn on or cancel memory function. If memory function is set,  is displayed. If not, indoor unit is defaulted to be off after power recovery.

If memory function is set, indoor unit will resume original setting state after power failure and then power recovery.

##### Note:

If cut off power with 5s after memorized content is changed, the memorized content may be abnormal. Do not cut off power within 5s after memorized content is changed.

#### 4.5 Door Control Function/Human Sensitive Function

Door control function or human sensitive function can be selected (More details please refer to Debugging Function). These two functions can't be turned on at the same time.

When door control function is selected, the wired controller will work when the room card is inserted and stop working when the room card is not inserted; when human sensitive function is selected, the wired controller will work when it senses there is somebody in the room and stop working when it senses there is nobody in the room. When the door control function senses the room card is not inserted or human sensitive function senses there is nobody in the room, the wired controller will display  icon.

##### Note:

①. In long-distance monitoring or centralized control, no matter the room card is inserted or not, the ON/OFF of unit can be controlled. If long-distance monitoring or centralized control information is received when the room card is not inserted,  icon is cleared. When the card is reinserted, door control function is judged to be turned on. If long-distance monitoring or centralized control information is received when the room card is inserted, it will keep the original status.

②. The unit can not be controlled by buttons when the card is not inserted.

③. When door control function and human sensitive function have been set at the same time, it is defaulted that door control function is valid and human sensitive function is invalid.

#### 4.6 Switch between Fahrenheit and Centigrade

Under off state of the unit, press Mode and ▼ buttons at the same time for 5s to switch between Fahrenheit and Centigrade.

#### 4.7 Enquiry of Ambient Temperature

Under off or on state of the unit, press it for 5s to view the ambient temperature. In this case, timer zone displays ambient temperature type 01 or 02. Ambient temperature zone displays the corresponding temperature of that type. 01 stands for outdoor ambient temperature and 02 stands for the indoor ambient temperature after compensation. Press Mode button to switch between 01 and 02. Pressing other buttons except Mode button or receiving remote control signal will exit enquiry state. If there is no operation within 20s will also exit enquiry state.

**Note:**

①. If the unit is not connected to outdoor ambient temperature sensor, display of outdoor ambient temperature will be shielding after energizing for 12hr.

②. If there is malfunction of outdoor ambient temperature sensor, display of outdoor ambient temperature will be shielding after energizing for 12hr.

## 4.8 Enquiry of Historical Malfunction

Under off or on state of the unit, continuously press Function and ▼ buttons for 5s to view historical malfunction.

In enquiry state, set temperature displaying zone displays “00”. Press ▲ and ▼ buttons to view the 5 malfunctions happened recently. The timer displaying position displays the detailed error code. The 5th displayed malfunction is the last malfunction.

## 4.9 Debugging Function

Under off state of the unit, press Function and Timer buttons at the same time for 5s to go to the debugging menu. Press Mode button to adjust the setting items and press ▲ or ▼ button to set the actual value.

### 4.9.1 Setting ambient temperature sensor (dual ambient temperature sensors function)

Under debugging state, press Mode button to adjust to “00” in temperature displaying zone. Timer zone displays setting state and press ▲ or ▼ button to adjust. There are 3 selections:

(1) The ambient temperature at air return is set as indoor ambient temperature (timer zone displays 01)

(2) The temperature at wired controller is set as indoor ambient temperature (timer zone displays 02)

(3) Select the temperature sensor at air return in cooling, dry and fan mode; select the temperature sensor at wired controller in heating and auto mode.

### 4.9.2 Selecting three speeds in high speed and three speeds in low speed of indoor fan motor

Under debugging state, press Mode button to adjust to “01” in temperature displaying zone. Timer zone displays setting state and press ▲ or ▼ button to adjust. There are 2 selections:

(1) Three speeds in low speed (LCD displays 01)

(2) Three speeds in high speed (LCD displays 02)

Three speeds in low speed include high, medium and low speeds; three speeds in high speed include super high, high and medium speed.

**Note:** For this series, this function is invalid.

### 4.9.3 Displaying setting of freeze protection error code

Under debugging state, press Mode button to adjust to “02” in temperature displaying zone. Timer zone displays setting state and press ▲ or ▼ button to adjust. There are 2 selections:

(1) Displayed (LCD displays 01)

(2) Not displayed (LCD displays 02)

It is defaulted to be not displayed for export unit and be displayed for domestic unit.

### 4.9.4 Setting refrigerant lacking protection function

Under debugging state, press Mode button to adjust to “04” in temperature displaying zone. Timer zone displays setting state and press ▲ or ▼ button to adjust. There are 2 selections:

- (1) With refrigerant lacking protection function (LCD displays 01)
- (2) Without refrigerant lacking protection function (LCD displays 02)

#### **4.9.5 Selecting blowing residual heating of indoor unit**

Under debugging state, press Mode button to adjust to “05” in temperature displaying zone. Timer zone displays setting state and press ▲ or ▼ button to adjust. There are 2 selections:

- (1) Mode 1 (LCD displays 00)
- (2) Mode 2 (LCD displays 01)

**Note:** Blowing residual heating of indoor unit

Mode 1: Unit stops when reaching temperature point and indoor fan motor does not stop in cooling mode; after unit stops when reaching temperature point in heating mode, duct type unit and floor ceiling unit blow residual heat for 60s and then stop indoor unit, while cassette type unit always operates in low fan speed and blows residual heat for 60s when there is malfunction.

Mode 2: After unit stops when reaching temperature point, the indoor fan motor stops operation with a 10s delay no matter in cooling mode or in heating mode.

#### **4.9.6 Mode selecting of compressor electric heating belt**

Under debugging state, press Mode button to adjust to “06” in temperature displaying zone. Timer zone displays setting state and press ▲ or ▼ button to adjust. There are 2 selections:

- (1) Mode 1 (LCD displays 00)
- (2) Mode 2 (LCD displays 01)

**Note:**

Mode 1: Compressor electric heating belt starts when outdoor ambient temperature is below 35°C and stops when outdoor ambient temperature is above 37°C. When outdoor ambient temperature is within 35°C~ 37°C, the belt will keep its previous operation state.

Mode 2: Compressor electric heating belt starts when outdoor ambient temperature is below -2°C and stops when outdoor ambient temperature is above 0°C. When outdoor ambient temperature is within -2°C~0°C, the belt will keep its previous operation state.

#### **4.9.7 Selecting low-power consumption mode**

Under debugging state, press Mode button to adjust to “07” in temperature displaying zone. Timer zone displays setting state and press ▲ or ▼ button to adjust. There are 2 selections:

- (1) With low-power consumption mode (LCD displays 00)
- (2) Without low-power consumption mode (LCD displays 01)

#### **4.9.8 Selecting door control function**

Under debugging state, press Mode button to adjust to “08” in temperature displaying zone. Timer zone displays setting state and press ▲ or ▼ button to adjust. There are 2 selections:

- (1) Without door control function (LCD displays 00)
- (2) With door control function (LCD displays 01)

#### **4.9.9 Selecting human sensitive function**

Under debugging state, press Mode button to adjust to “09” in temperature displaying zone. Timer zone displays setting state and press ▲ or ▼ button to adjust. There are 2 selections:

- (1) Without human sensitive function (LCD displays 00)
- (2) With human sensitive function (LCD displays 00)

#### 4.9.10 Selecting long-distance monitoring or centralized controller

Under debugging state, press Mode button to adjust to “10” in temperature displaying zone. Timer zone displays setting state and press ▲ or ▼ button to adjust. There are 2 selections:

- (1) Centralized controller (LCD displays 00)
- (2) Long-distance monitoring (LCD displays 01)

#### 4.9.11 Selecting fan mode of indoor fan motor

Under debugging state, press Mode button to adjust to “11” in temperature displaying zone. Timer zone displays setting state and press ▲ or ▼ button to adjust. There are 9 selections:

- (1) P1 (LCD displays 01)
- (2) P2 (LCD displays 02)
- (3) P3 (LCD displays 03)
- (4) P4 (LCD displays 04)
- (5) P5 (LCD displays 05)
- (6) P6 (LCD displays 06)
- (7) P7 (LCD displays 07)
- (8) P8 (LCD displays 08)
- (9) P9 (LCD displays 09)

**Note:** You can select P1,..... P9 in fan mode of indoor fan motor, which means different fan mode combinations are corresponding to different static pressure. Ex-factory defaulted mode is P5. You can set the mode through wired controller. S01, S02, S03.....S12, S13 means the rotation speed of indoor unit is from low to high.

Table 2-4-2 Combination relationship of P1 to P9

Static pressure selection	External Static Pressure (Pa)	Super high speed	High speed	Medium high speed	Medium speed	Medium low speed	Low speed	Quiet R1 speed	Quiet R2 speed	Quiet R13 speed
P1	10	S05	S03	S02	S02	S01	S01	S01	S01	S01
P2	20	S06	S04	S03	S03	S02	S02	S02	S02	S02
P3	30	S07	S05	S04	S04	S03	S03	S03	S03	S03
P4	40	S08	S06	S05	S05	S04	S04	S04	S04	S04
P5	50	S09	S07	S06	S06	S05	S05	S05	S05	S05
P6	75	S10	S08	S07	S07	S06	S06	S06	S06	S06
P7	100	S11	S09	S08	S08	S07	S07	S07	S07	S07
P8	150	S12	S10	S09	S09	S08	S08	S08	S08	S08
P9	200	S13	S11	S10	S10	S09	S09	S09	S09	S09

#### 4.9.12 Selecting compensation of temperature sensor at air return

Under debugging state, press Mode button to adjust to “12” in temperature displaying zone. Timer zone displays setting state and press ▲ or ▼ button to adjust. There are 16 selections:

- (1) Compensate 0°C (LCD displays 00)
- (2) Compensate 1°C (LCD displays 01)
- (3) Compensate 2°C (LCD displays 02)
- (4) Compensate 3°C (LCD displays 03)
- (5) Compensate 4°C (LCD displays 04)
- (6) Compensate 5°C (LCD displays 05)
- (7) Compensate 6°C (LCD displays 06)
- (8) Compensate 7°C (LCD displays 07)
- (9) Compensate 8°C (LCD displays 08)
- (10) Compensate 9°C (LCD displays 09)
- (11) Compensate 10°C (LCD displays 10)
- (12) Compensate 11°C (LCD displays 11)
- (13) Compensate 12°C (LCD displays 12)
- (14) Compensate 13°C (LCD displays 13)
- (15) Compensate 14°C (LCD displays 14)
- (16) Compensate 15°C (LCD displays 15)

**Note:** Indoor ambient temperature compensation can be set through wired controller (E.g. If 02 is selected, it indicates the compensation temperature is 2°C. If the indoor ambient temperature detected by the temperature sensor at air return is 29°C, the ambient temperature after compensation is  $29^{\circ}\text{C}-2^{\circ}\text{C}=27^{\circ}\text{C}$ ).

After finishing setting, press Enter/Cancel button to save and exit setting. After entering this interface, the system will exit this menu if there is no operation on the button within 20s. Normal off state interface will be displayed and present setting will not be saved.

## 5 INSTALLATION OF WIRED CONTROLLER

### 5.1 Standard Accessories

Table 2-5-1 Standard Accessories of Wired Controller

Description	Quantity	Note
Socket base box installed in the wall	1	No.1 in Figure 2-5-1
Base plate of wired controller	1	No.2 in Figure 2-5-1
Screw M4×25	2	No.3 in Figure 2-5-1
Panel of wired controller	1	No.4 in Figure 2-5-1



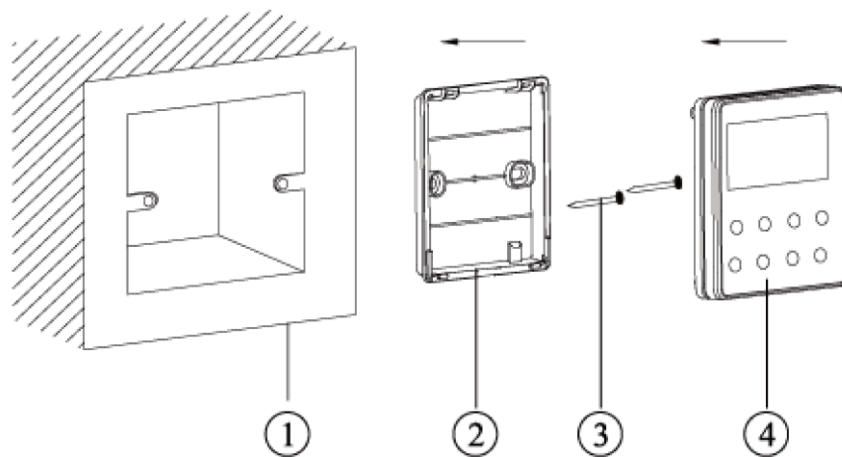

Figure 2-5-1

## 5.2 Installation Position and Requirement

(1) Prohibit installing the wired controller at the misty place or the place with direct sunlight.

(2) Prohibit installing the wired controller at the place near high temperature objects or water-splashing places.

(3) Prohibit installing the wired controller at the place where faces forward to the window, to avoid interference of another remote controller from neighborhood.

(4) Cut off the power of heavy current wire in the installation hole of the wall. All power should be cut off during installation.

(5) In order to avoid abnormal operation due to electromagnetic interference, etc., pay attention to the following notes during connecting wires:

1) Make sure the tie-in interface of communication wire is correct, otherwise it may lead to communication malfunction.

2) The signal wires and communication wires of wired controller should be separated from power cord and connection wire between indoor unit and outdoor unit.

3) If the air conditioner is installed at the strong electromagnetic interference place, signal wire and communication wire of wired controller must use shielding twisted wire.

## 5.3 Installation of Wired Controller

Firstly, the selection and connection way of wired controller's signal wire are as below:

(1) Choose suitable signal wire: 2-core signal wire (wire diameter  $\geq 0.75\text{mm}$ , wire length  $< 30\text{m}$  and the recommended length is 8m).

(2) Make sure the power of indoor unit is cut off; fix the signal wire of wired controller on the wiring board for wired controller of indoor unit with screws; make sure the signal wire is solid.

Then, the detailed installation procedures of wired controller are as shown in Figure 2-5-2:

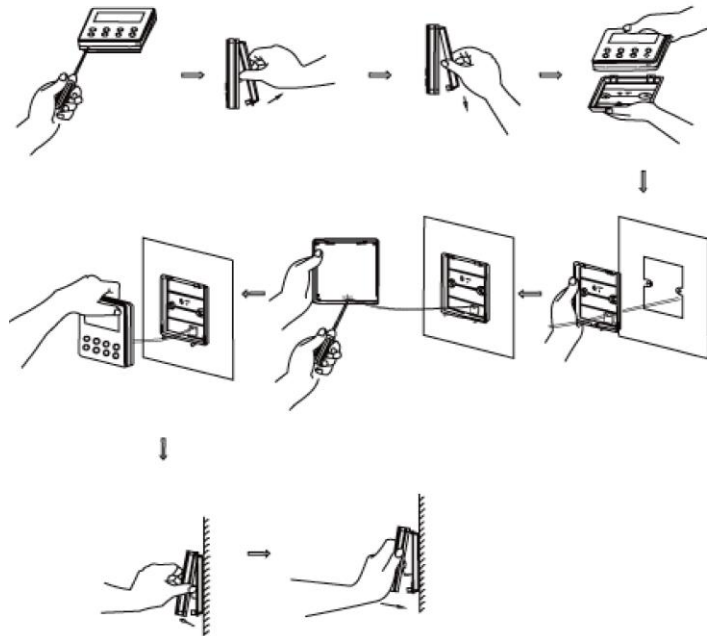

Figure 2-5-2 Installation of wired controller

Brief instructions of installation procedure:

- 1) Pull out the 2-core signal wire in the installation hole of the wall and then let this wire go through the hole at the back of wired controller's base plate.
- 2) Fix the base plate and installation hole of the wall together with screw M4×25.
- 3) Fix the above mentioned 2-core signal wire on the copper insert X1 and X2 with the equipped screws of wired controller.
- 4) Fasten the wired controller's panel with its base plate together.

## 5.4 Removal of Wired Controller

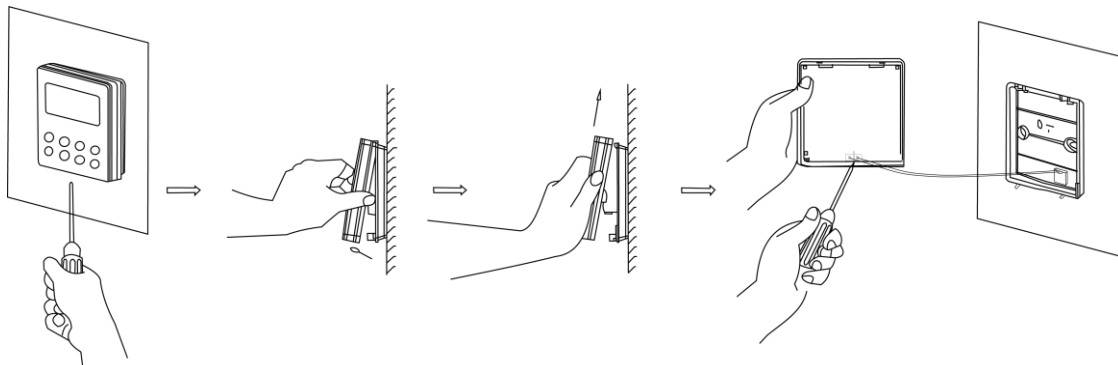

Figure 2-5-3 Removal of wired controller

# 6 TROUBLE SHOOTING

## 6.1 Display of Error Code

Table 2-6-1 Error Code List

Error Code	Error
E1	Compressor high pressure protection
E2	Freeze protection
E3	Compressor low pressure protection, refrigerant lacking protection, refrigerant recycling mode

E4	Compressor high discharge temperature protection
E6	Communication malfunction
E8	Malfunction of indoor fan motor
E9	Full water protection
F0	Malfunction of indoor ambient temperature sensor
F1	Malfunction of evaporator temperature sensor
F2	Malfunction of condenser temperature sensor
F3	Malfunction of outdoor ambient temperature sensor
F4	Malfunction of discharge temperature sensor
F5	Malfunction wired controller temperature sensor
C4	Outdoor unit Capacity code error
C5	Indoor unit Capacity code error
EE	Malfunction of outdoor main control memory chip
PF	Malfunction of electric box sensor
H3	Compressor overload protection
H4	Overload protection
H5	IPM protection
H6	Malfunction of DC fan motor
H7	Drive desynchronizing protection
HC	PFC protection
Lc	Start-up failure
Ld	Compressor phase protection
LF	Power protection
Lp	Models of indoor unit and outdoor unit do not match with each other
U7	Direction changing malfunction of 4-way valve
P0	Drive reset protection
P5	Overcurrent protection
P6	Communication malfunction between main control and drive
P7	Malfunction of drive module sensor
P8	High temperature protection of drive module
P9	Zero-cross protection
PA	AC current protection
PC	Malfunction of drive current
Pd	Sensor connection protection
PE	Temperature excursion protection
PL	Low voltage protection of bus bar
PH	High voltage protection of bus bar
PU	Charging circuit malfunction
PP	Abnormity of input voltage
ee	Malfunction of outdoor drive memory chip
oE	Malfunctions of outdoor unit, please refer to status of error indicator in outdoor unit

When there is a malfunction during operation, error will be displayed on the temperature displaying zone of LCD. When several malfunctions occur at the same time, these error code will be displayed circularly.

When there is a malfunction, please turn off the unit and ask the professional for maintenance.  
 For example, E1 means high pressure protection during operation.

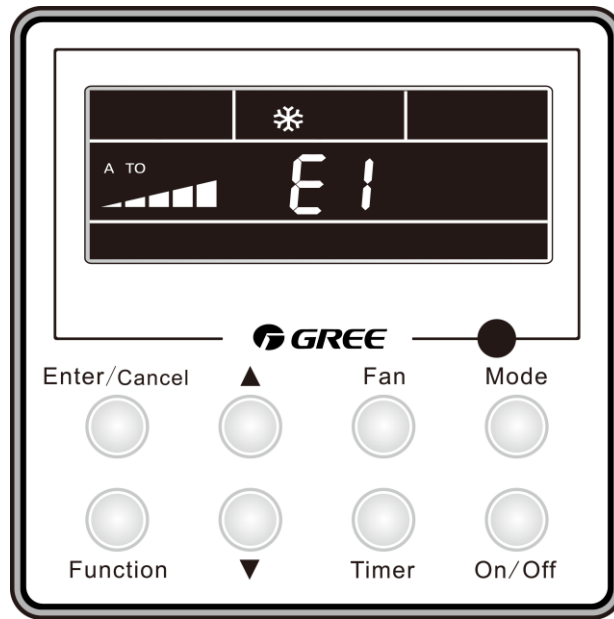

Figure 2-6-1

## 7 CENTRALIZED CONTROLLER

### 7.1 Smart Zone Controller

#### 7.1.1 Function

The smart zone controller can directly control up to 16 sets of indoor units in a control network and is available to check the running status of any unit through the LCD, including running mode, timer, fan speed, centralized control and shielding setting etc.

#### 7.1.2 Outline Drawing of Press Buttons



Figure 2-7-1

### 7.1.3 Functions of Press Buttons

Table 2-7-1 Functions of Press Buttons

No.	Name	Function Description
1	Mode	It is used for the switchover among different modes.
2	Fan	It is used to set the fan speed, <i>high</i> , <i>medium</i> , <i>low</i> or <i>auto</i> .
3	On/Off	It is used to set the on/off status of the indoor unit.
4	▲	1. Under the single/centralized control status: It is used to set the running temperature of the indoor unit with max.30°C anmin.16°C; 2. Under the timing setting status: It is used to set the timing period with max.24 hours and min.0 hour; 3. Under the clock setting status: it is used to set the hour (max.:23, min.: 0) and minute (max.:59, min.: 0) of the clock.
5	▼	
6	Mon 1/9	It is used for the switchover between unit 1 and unit 9; Under the timing or clock setting status, it indicates Monday.
7	Tue 2/10	It is used for the switchover between unit 2 and unit 10; Under the timing or clock setting status, it indicates Tuesday.
8	Wed 3/11	It is used for the switchover between unit 3 and unit 11; Under the timing or clock setting status, it indicates Wednesday.
9	Thu 4/12	It is used for the switchover between unit 4and unit 12; Under the timing or clock setting status, it indicates Thursday.
10	Fri 5/13	It is used for the switchover between unit 5and unit 13; Under the timing or clock setting status, it indicates Friday.
11	Sat 6/14	It is used for the switchover between unit 6 and unit 14; Under the timing or clock setting status, it indicates Saturday.
12	Sun 7/15	It is used for the switchover between unit 7 and unit 15; Under the timing or clock setting status, it indicates Sunday.
13	8/16	It is used for the switchover between unit 8 and unit 16.
14	Timer/Time	It is used to set the timing or on/off time of the selected indoor unit as well as to set the clock of the system.
15	Central	It is used for the switchover between single and centralized control modes.
16	Shield	It is used to deactivate some or all functions of a single or a group the indoor unit(s).
17	All on/off	It is used to start/stop all indoor units.

### 7.1.4 LCD of the Controller

#### 7.1.4.1 Outline Drawing of the LCD

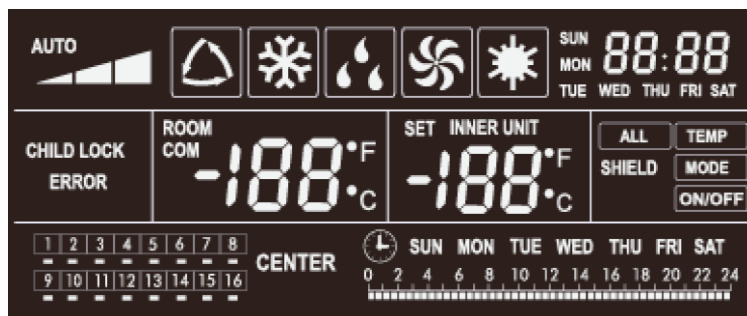

Figure 2-7-2

### 7.1.4.2 Introduction to Symbols on the LCD



Figure 2-7-3

Table 2-7-2 Introduction to the Symbols on the LCD

No.	Name	Description
1	Fan speed	It displays the fan speed of the indoor unit, high, medium, low and auto.
2	Running mode	It displays the running mode of the indoor unit, auto, cool, dry, fan and heat.
3	System clock	It displays the current time (hour and minute) in 24-hour time system and also the week day.
4	Shield	It displays the shield status, "ALL", "TEMP", "MODE" and 'On/Off'.
5	Weekly timer	It displays the timing period (unit: 0.5 hour) which will circulate every week.
6	Set temperature Indoor unit code	It displays the set temperature, indoor unit code (01-16), and symbols of Celsius and Fahrenheit scale.
7	Control mode	It displays "CENTER" under the centralized control mode and no display under the single control mode.
8	Ambient temperature Serial port	It displays the ambient temperature, serial port as well as symbols of Celsius and Fahrenheit scale.
9	Indoor unit code On/off status	Numbers indicate the indoor unit codes which will be displayed when the corresponding indoor unit is online; "" indicates the on/off status of the indoor unit, its flashing for "on" or else for "off"
10	Error Child lock	It displays the error codes when some error(s) arises and also "CHILD LOCK" when this function is activated.

### 7.1.4.3 Network Topology

#### Network Connection of the Smart Zone Controller

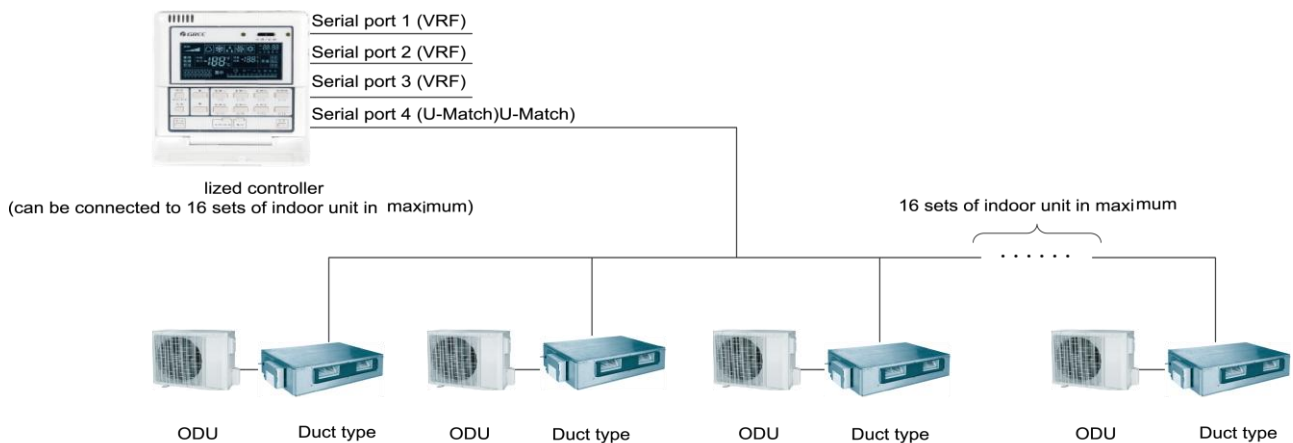

Figure 2-7-4

### 7.1.4.4 Dimensions

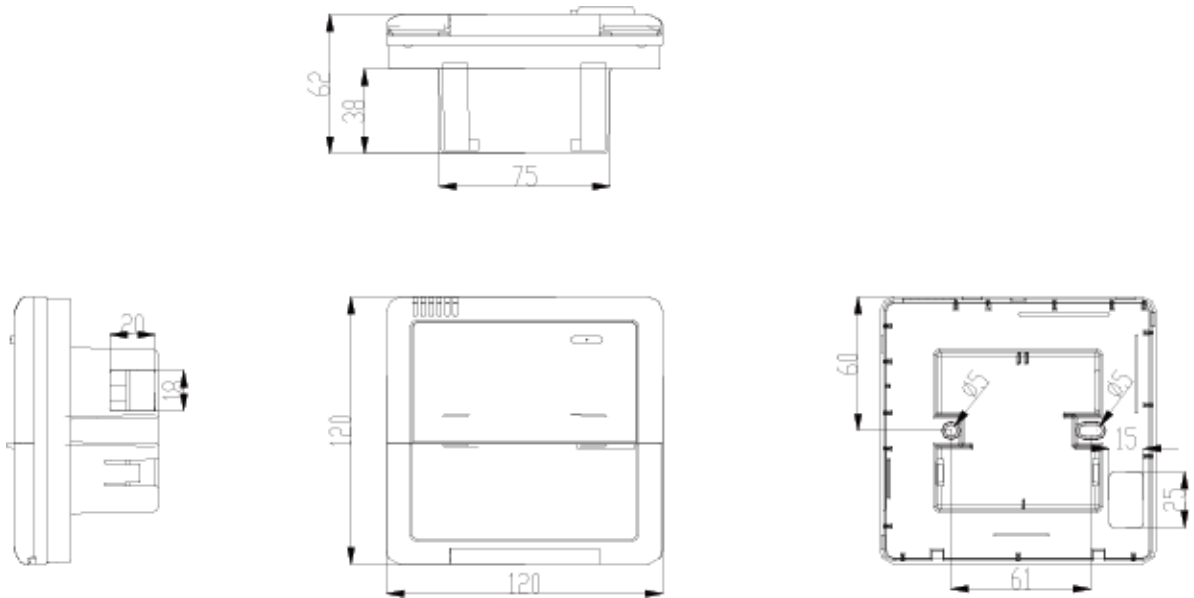

Figure 2-7-5

## 7.2 Additional Special Functions

### 7.2.1 Door control function

Door control function is available for this series. In order to achieve this function, please select the door control accessories from Gree.

(1) Interface instructions

1) The interface printing is DOOR-C and the type is B2B-XH-B. The wires of door control accessories must be connected to this interface;

2) Electrical characteristic: none;

3) Working principle: when the card is inserted, this interface is short-circuited; when the card is not inserted, this interface is cut off;

Connect the door control detection port of indoor mainboard with the interface of door control board (CN1 in the following Figure); connect the door control signal to the door control signal input port (X1 and X2 in the following Figure). X1 is AC 220V signal input and X2 is DC +5V to 24V. You can only choose X1 or X2. Definition of interface is as shown in Figure below:

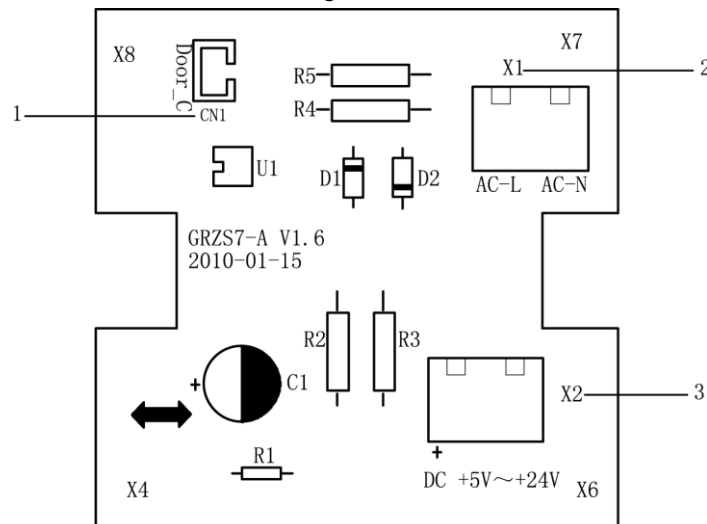



Figure 2-7-6 Illustration of door control port

Table 2-7-3 Door control wiring port

No.	Terminal name	Terminal instruction
1	CN1	CN1 wiring terminal and door control interface of indoor mainboard
2	X1(AC-L, AC-N)	X1(AC-L, AC-N) wiring terminal, connected to door control input signal, rated voltage 220V.
3	X2	X2 wiring terminal, connected to door control input signal

## (2) Function instructions:

In order to achieve this function, set it through wired controller and refer to the following operation method. It is defaulted that this function is not activated; if this function is set and door control accessories are connected, the unit will control the ON/OFF of unit according to the card state detected by door control detection board. When the card is not connected, the unit will turn to standby state. If the unit is with wired controller,  icon will be displayed on the wired controller.

If the unit is without wired controller, there will be no display. The unit will control the ON/OFF of unit according to the detected information.

## (3) Setting method:

Under off state of the unit, press Function and Timer buttons at the same time for 5s to go to the debugging menu. Press Mode button to adjust to "08" in temperature displaying zone. Timer zone displays setting state and press ▲ or ▼ button to adjust. There are 2 selections:

- 1) Without door control function (LCD displays 00)
- 2) With door control function (LCD displays 01)

Choose the second selection and then press Enter/Cancel button to save and exit setting. Now, door control function is activated. The unit will memorize this setting status. The setting value will be memorized after power failure. The detailed setting is as shown in the Figure below:



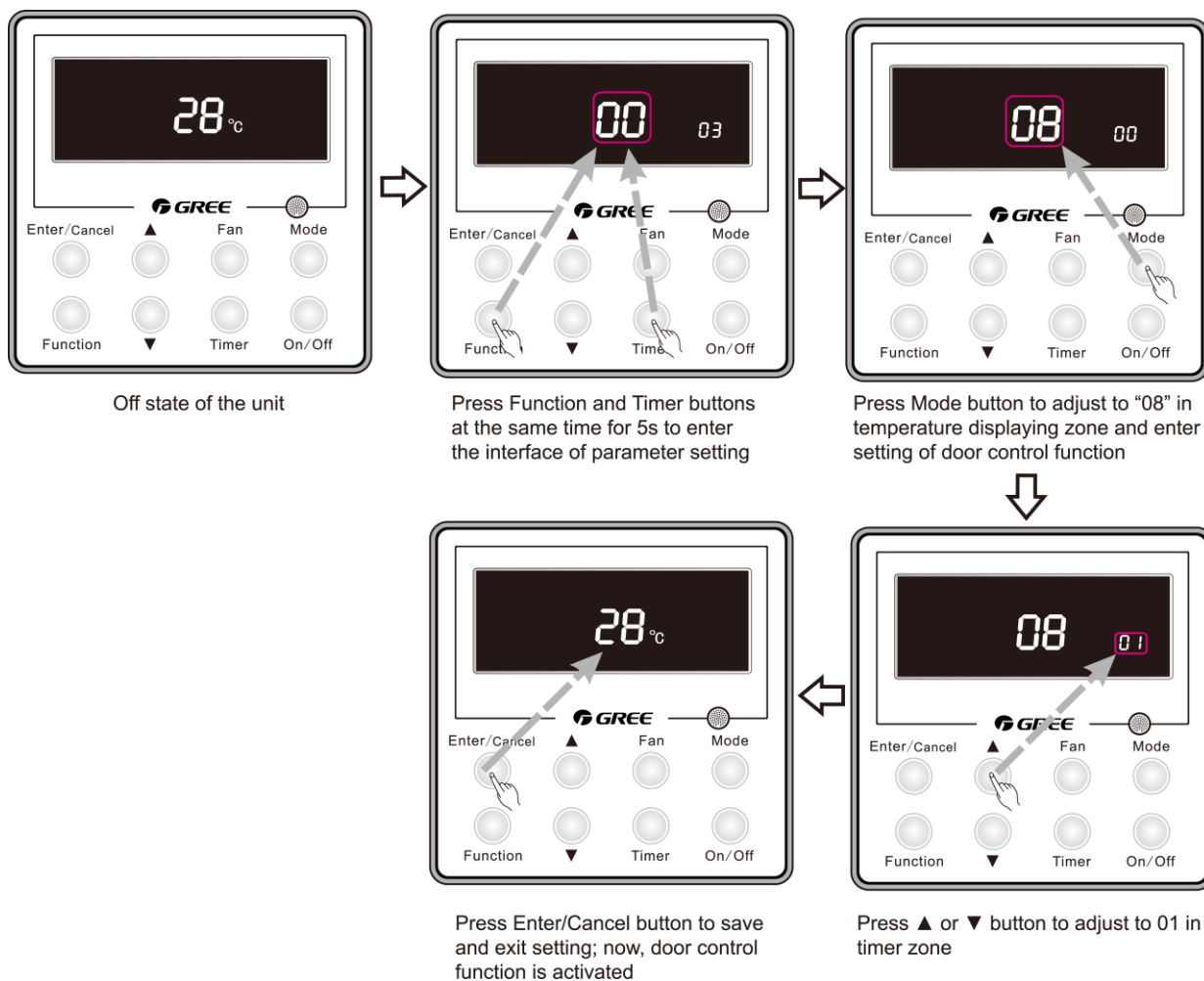

Figure 2-7-7

**Note:**

You can purchase the accessory from Gree. The information is as below:

Name	Product code	Remark
Controller for door control function (MK03)	MC207022	One controller for one unit

**7.2.2 Human sensitive function**

You can purchase the module of human sensitive function for this series. An interface for this module is reserved on the mainboard of indoor unit.

(1) Interface instruction:

- 1) The printing is CN23 and the interface type is JST B3B-PH-K-S;
- 2) Electrical characteristic: 1-pin: +12V; 2-pin: detection port; 3-pin: GND; current: 150mA;
- 3) Working principle: when the module detects there is nobody in the room, 2-pin and 3-pin are short-circuited and they are low electrical level; when there are somebody in the room, 2-pin output is high electrical level.

(2) Function instructions:

In order to achieve this function, set it through wired controller and refer to the following operation method. It is defaulted that this function is not activated; if this function is set and human sensitive module is connected, the unit will control the ON/OFF of unit according to the signal detected by human sensitive module. When there is nobody in the room and the unit is with wired controller,  icon will be

displayed on the wired controller; if the unit is without wired controller, there will be no display. The unit will control the ON/OFF of unit according to the detected information.

(3) Setting method:

Under off state of the unit, press Function and Timer buttons at the same time for 5s to go to the debugging menu. Press Mode button to adjust to “09” in temperature displaying zone. Timer zone displays setting state and press ▲ or ▼ button to adjust. There are 2 selections:

- 1) Without human sensitive function (LCD displays 00)
- 2) With human sensitive function (LCD displays 01)

Choose the second selection and then press Enter/Cancel button to save and exit setting. Now, human sensitive function is activated. The unit will memorize this setting status. The setting value will be memorized after power failure. The detailed setting is as shown in the Figure below:

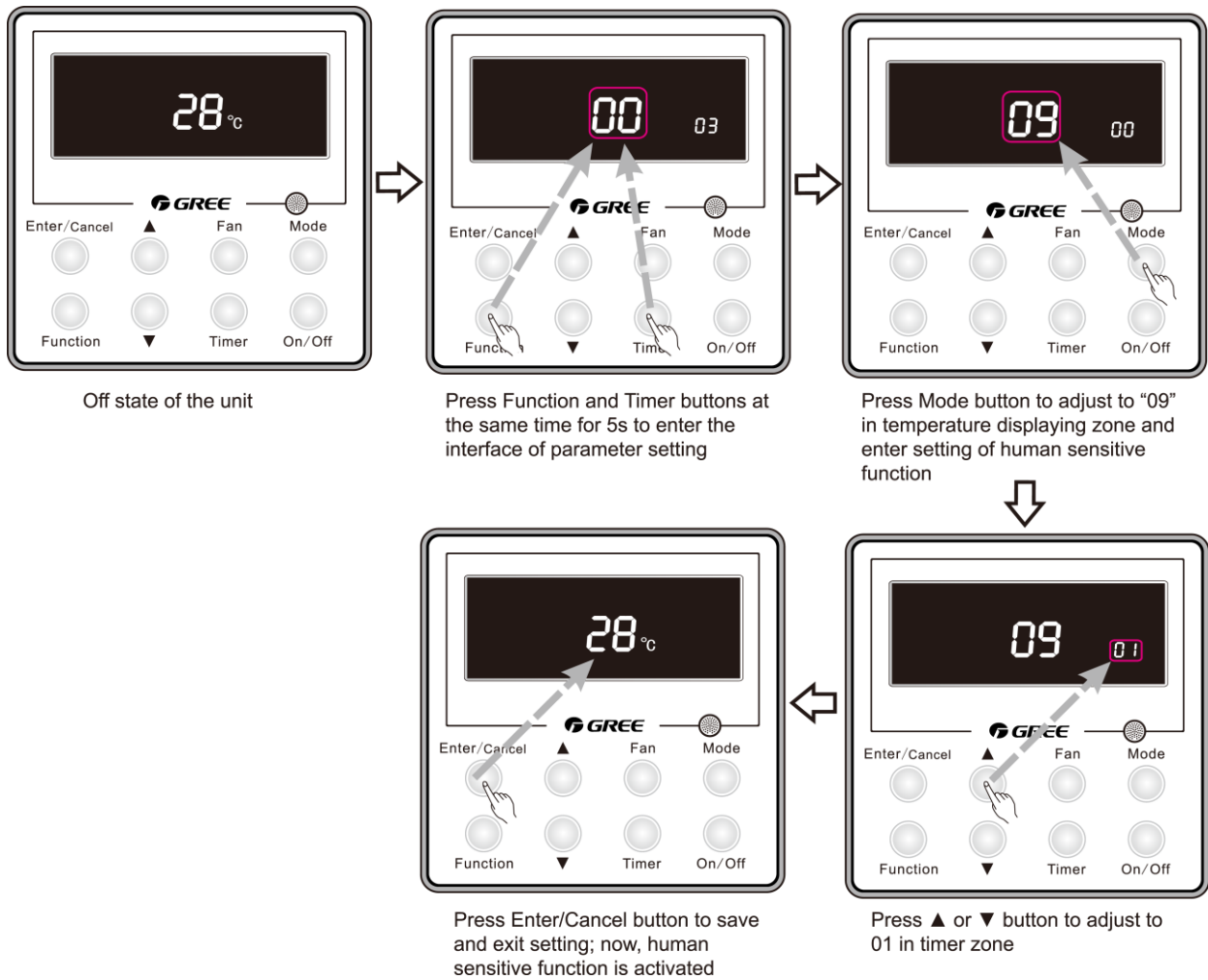

Figure 2-7-8

**Note:**

When door control function and human sensitive function have been set at the same time, it is defaulted that door control function is valid and human sensitive function is invalid.

The user can purchase the human sensitive module by himself. Please pay attention to the following notes:

- ①. There is the needle stand interface on the mainboard. The interface model inserted into this needle stand must be PH-3P-K;

②. The current consumption of module can not exceed the current capacity provided by this interface.

### 7.2.3 MODBUS interface

The indoor unit of this series has MODBUS interface. If the user needs to connect the unit to the management system of the building, please enquire Gree for the MODBUS protocol.

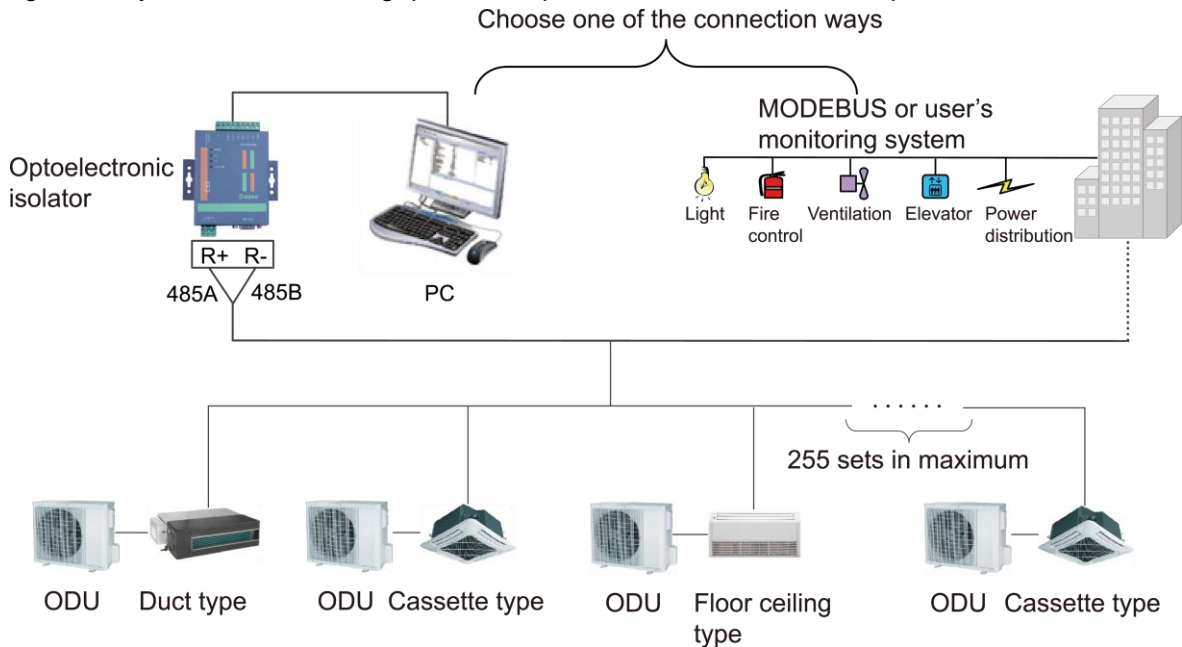

Figure 2-7-9

(1) Interface instruction:

- 1) The printing is COM-BMS1 and the interface type is B4B-XH-K3;
- 2) Electrical characteristic: baud rate: 9600bps; standard: RS485;
- 3) Working principle:

4) The indoor mainboard can send out the unit operation state through this interface and receive logical control information to realize control and monitor of the unit.

(2) Function instructions:

In order to achieve this function, set the address mode and address through wired controller. Please refer to Point 3 for the setting method. You must set the address mode into long-distance control address mode.

The address mode is defaulted to be connecting to centralized controller mode and the defaulted address is 1.

(3) Setting method:

1) Firstly, set the address mode of wired controller into centralized controller address mode. The setting method is:

Under off state of the unit, press Function and Timer buttons at the same time for 5s to go to the debugging menu. Press Mode button to adjust to "10" in temperature displaying zone. Timer zone displays setting state and press ▲ or ▼ button to adjust. There are 2 selections:

- ①. Centralized controller address mode (LCD displays 00)
- ②. Long-distance control address mode (LCD displays 01)

Choose the second selection and then press Enter/Cancel button to save and exit setting. Now, the

address of wired controller is set to match the address of long-distance control. The unit will memorize this setting status. The setting value will be memorized after power failure. The detailed setting is as shown in the Figure below:

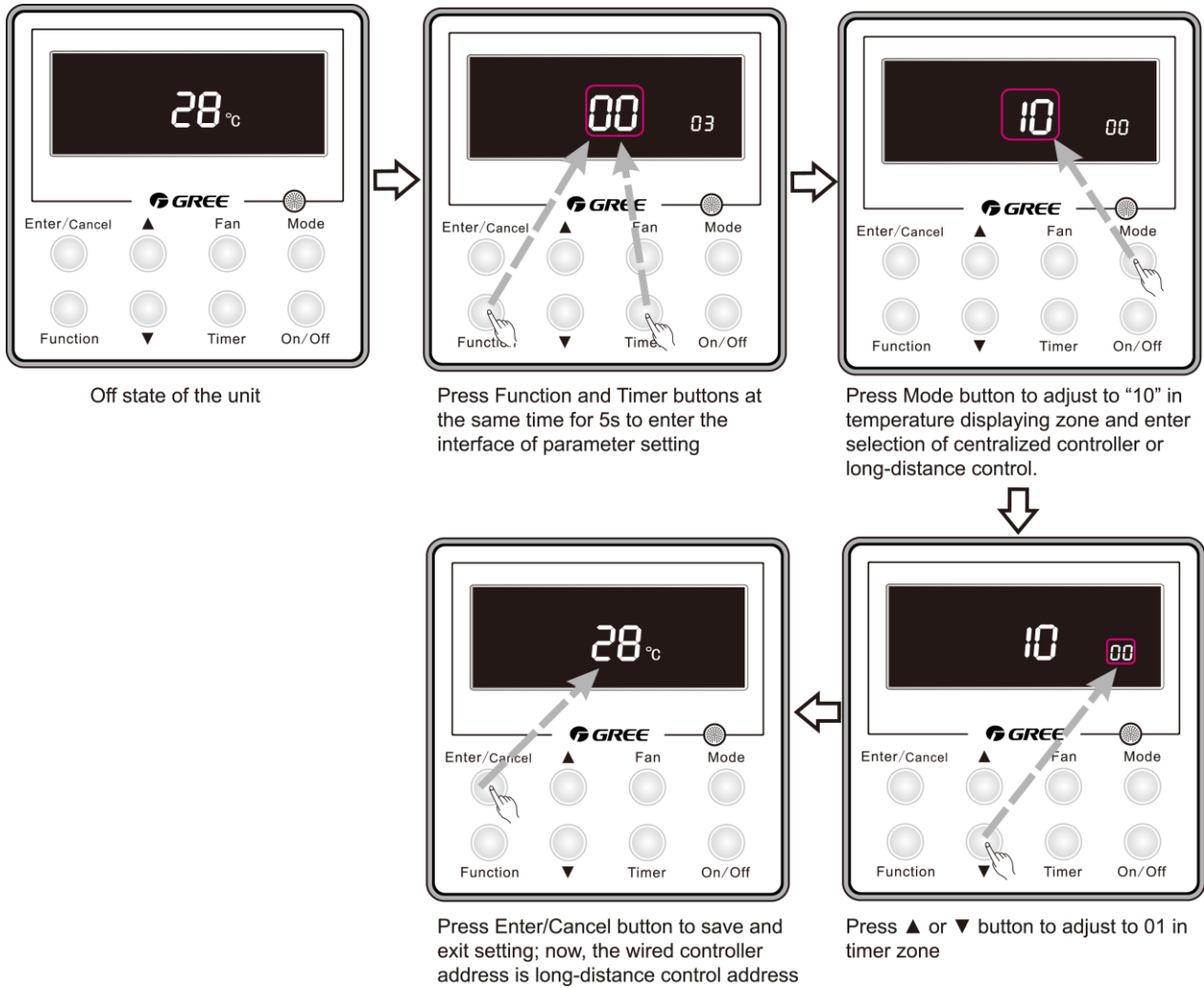

Figure 2-7-10

2) Address setting of each unit: when the address mode is set to be long-distance control address mode. The address setting value range is 01~255. The setting method is:

Under off state of the unit, press Function and Mode buttons at the same time for 5s to enter setting interface of wired controller address. LCD displays address sequence. Press ▲ or ▼ button to adjust the address sequence and then press Enter/Cancel button to confirm. The setting value will be memorized after power failure. The detailed setting is as shown in the Figure below:

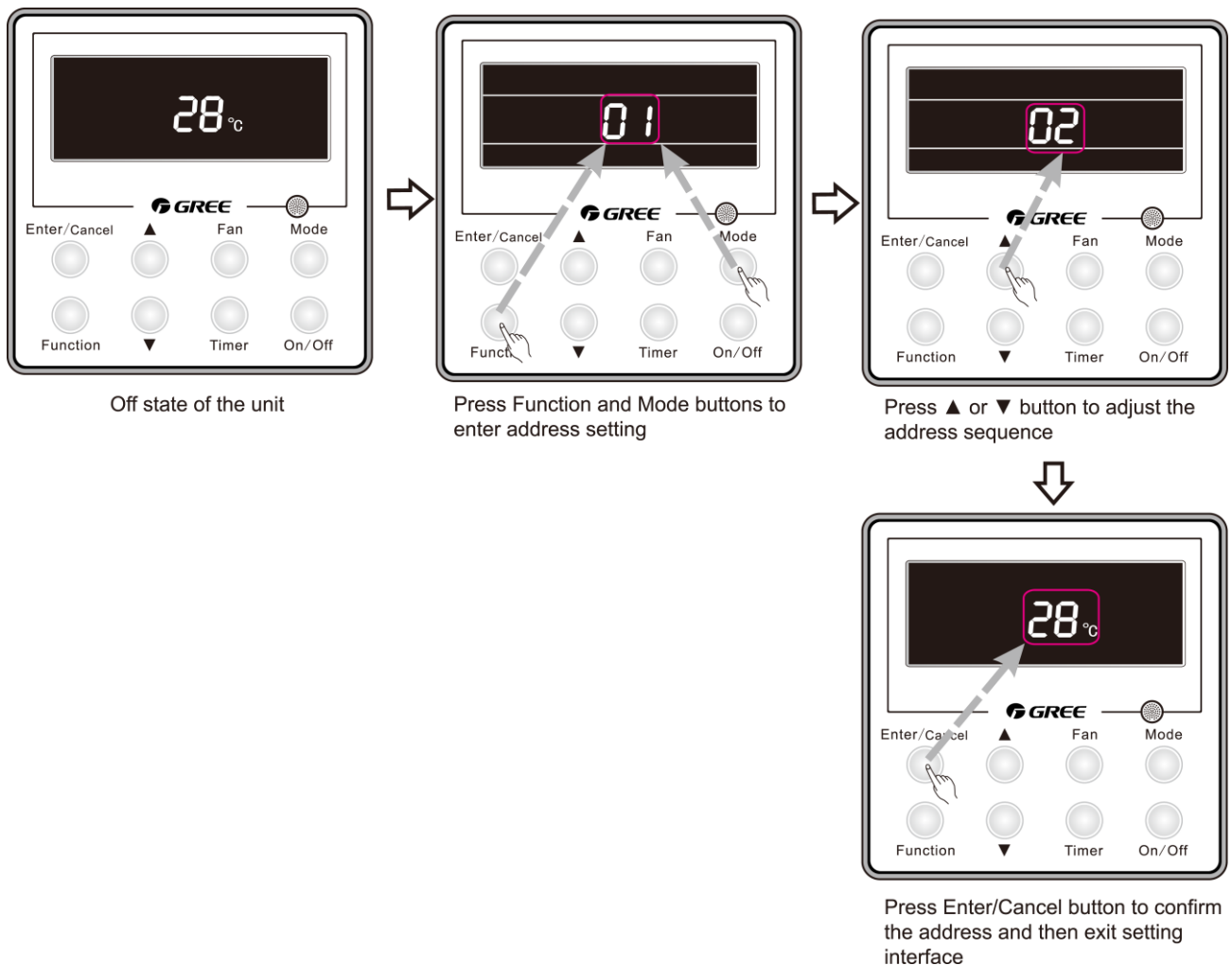

Figure 2-7-11

**Note:**

- ①. In order to realize the MODBUS interface function, the address mode of the unit must be set into long-distance control address mode; you can not set it into centralized control address mode, otherwise, this function can not be realized;
- ②. The unit can not be connected to MODBUS and centralized controller at the same time; only one of them can be selected;
- ③. 255 sets of unit in maximum can be connected in the same network; the unit addresses in the same network must be different, otherwise, the unit control will be affected;
- ④. Perform wiring when the unit power is cut off.

**7.2.4 Connect to interface of centralized controller:**

The indoor unit is with the interface of centralized controller. When centralized controller is connected, centralized control of unit can be realized when the wired controller is not connected;

(1) Interface instruction:

- 1) The printing is COM-BMS2, COM-BMS3 and the interface type is B2B-XH-K3;
- 2) Electrical characteristic: none;
- 3) Working principle: centralized control the communication of indoor mainboard and realize the unit control;

(2) Function instructions:

In order to achieve this function, set the address mode and address through wired controller. Please refer to Point 3 for the setting method. The address mode is defaulted to be connecting to centralized controller mode and the defaulted address is 1;

When the centralized controller is connected, centralized control of the unit can be realized to control unit ON/OFF, operation mode, set fan speed/temperature and weekly timer.

(3) Setting method:

Firstly, set the address mode of wired controller into centralized controller address mode. The setting method is:

1) Under off state of the unit, press Function and Timer buttons at the same time for 5s to go to the debugging menu. Press Mode button to adjust to “10” in temperature displaying zone. Timer zone displays setting state and press ▲ or ▼ button to adjust. There are 2 selections:

- ①. Centralized controller address mode (LCD displays 00)
- ②. Long-distance control address mode (LCD displays 01)

Choose the first selection and then press Enter/Cancel button to save and exit setting. Now, the address of wired controller is set to match the address of centralized controller. The unit will memorize this setting status. The setting value will be memorized after power failure. The detailed setting is as shown in the Figure below:

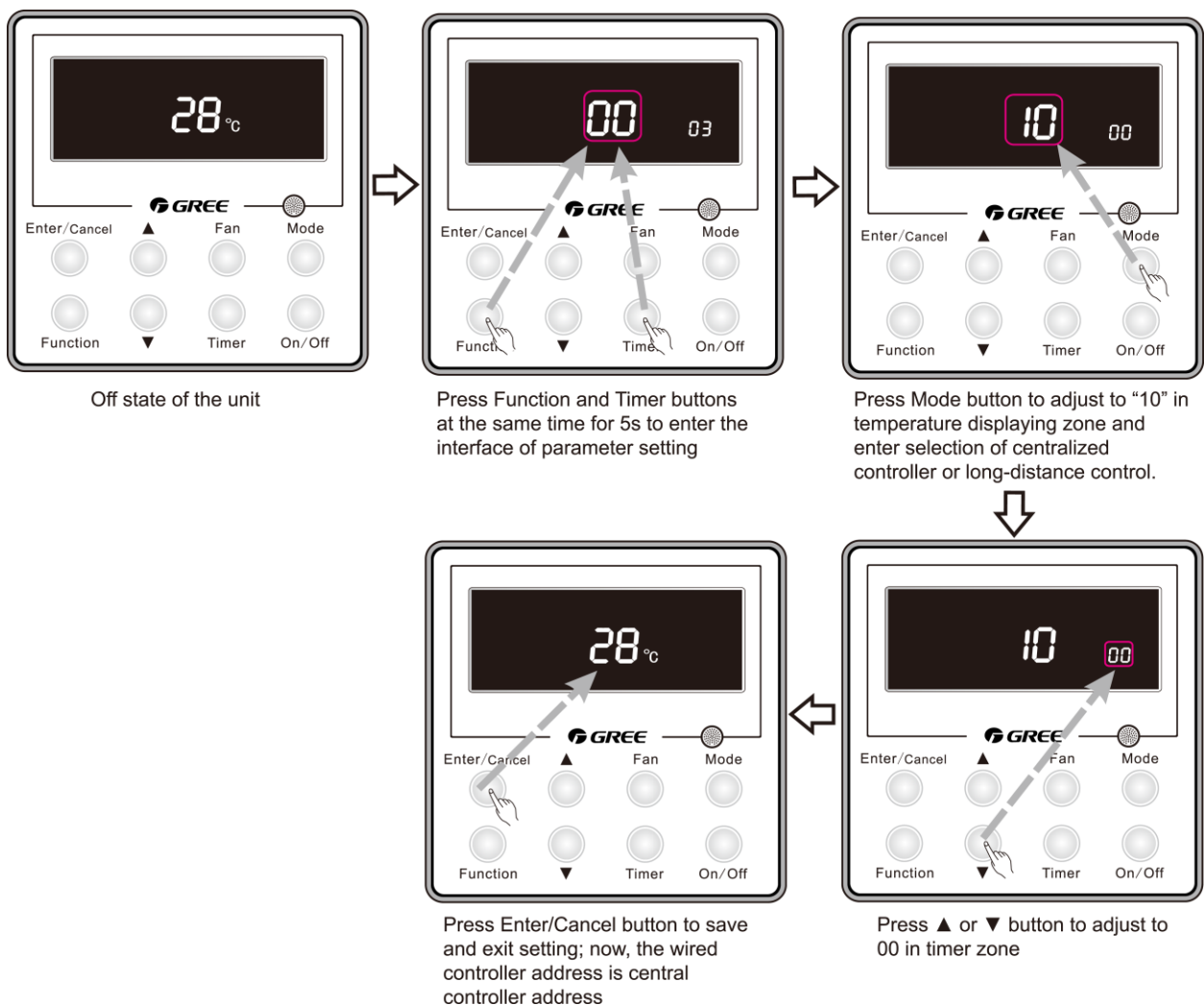

Figure 2-7-12

2) Address setting of each unit: when the address mode is set to be centralized controller address mode. The address setting value range is 01~16. The setting method is:

Under off state of the unit, press Function and Mode buttons at the same time for 5s to enter setting interface of wired controller address. LCD displays address sequence. Press ▲ or ▼ button to adjust the address sequence and then press Enter/Cancel button to confirm. The setting value will be memorized after power failure. The detailed setting is as shown in the Figure below:

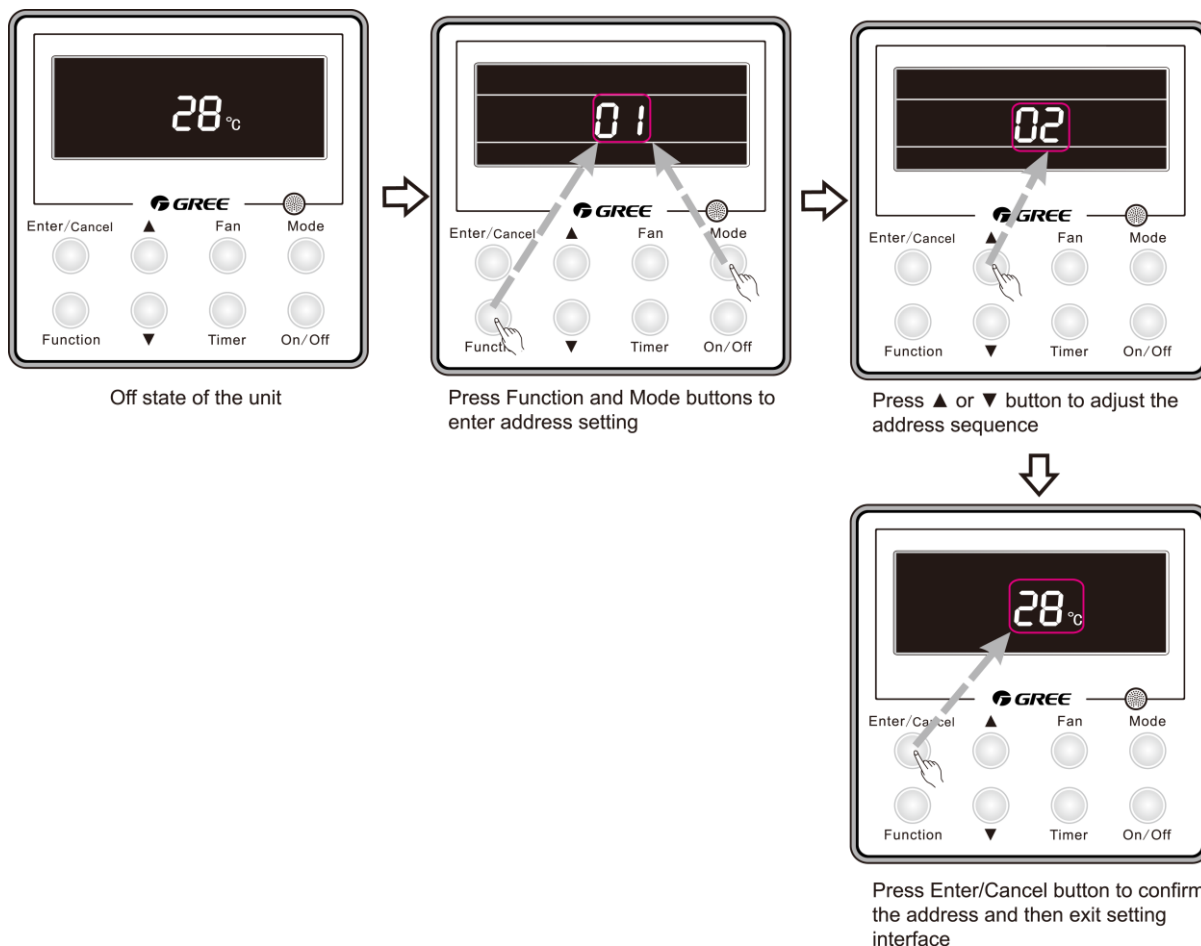

Figure 2-7-13

When the address is set, the wired controller can be removed and connect the centralized controller to the indoor mainboard. Then connect the required units to realize centralized control of these units;

**Note:**

- ①. When centralized controller is to be connected, set the address mode into centralized controller address mode through wired controller. Long-distance control address mode can not be set;
- ②. The unit addresses in the same network must be different, otherwise, communication malfunction will occur and the unit can not work normally;
- ③. When centralized controller is to be connected, the unit address range is 1-16. Only 16 sets of unit in maximum can be connected
- ④. The code and model of wired controller is as below:

Name	Product code	Remark
Centralized controller CE50-24/E	MC207025	Only 16 sets of unit in maximum can be connected to this controller

## 7.2.5 Light board control:

Light board interface is reserved on the mainboard of duct type unit. You can purchase Gree light board to realize control of the unit. When wired control is also connected, you can realize control of the unit through light board and wired controller.

Light board information:

Name	Product code	Remark
Receiving board Z6L	30260000001	Only for duct type unit

There are two buttons on the light board to control ON/OFF of cooling and heating. There are also other indicators and nixie tube display.

Cooling: set temperature 26°, low fan speed; heating: set temperature 20°, low fan speed

Function instructions: under OFF state, pressing Cool/Heat button can turn on cooling/heating mode. Under unit ON state, pressing Cool/Heat button can turn off the unit. When the unit is in cooling/heating mode, pressing any button can turn off the unit.

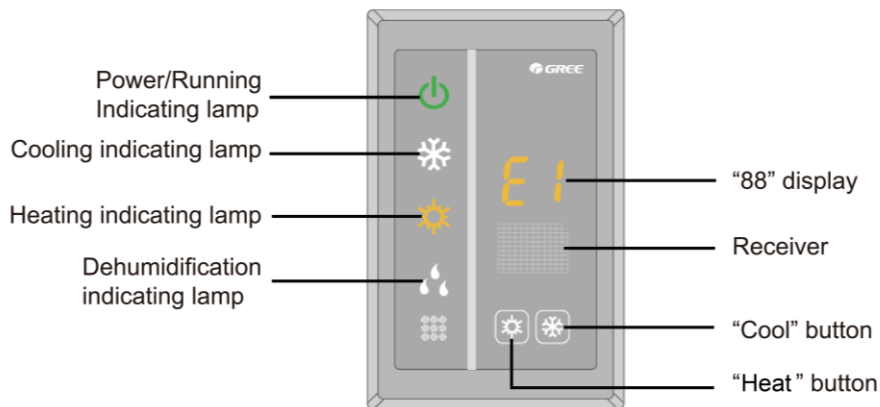

Figure 2-7-14

## 7.2.6 Malfunction output of relay:

There is malfunction outlet signal on the mainboard of indoor unit; when the unit occurs unrecovered malfunction, this signal will be output.

(1) Interface instruction:

1) Printing: X5, ERROR

2) Electrical characteristic OF malfunction indicator or electric bell: 220V~AC, power  $\leq 10W$

3) Working principle: when the unit occurs unrecovered malfunction, the relay will suck and 220V AC signal will be output.

(2) Function instructions:

When the user needs centralized control over several units, malfunction signals can be connected to control room through this malfunction output interface. The user can indicate the unit malfunction through malfunction indicator or electric bell, so the management people can go to check the malfunction unit directly.

If dry contact detection of unit malfunction is needed, please connect this interface into the monitoring system. When the closed signal is detected when malfunction occurs, this signal can be seen in monitoring system.



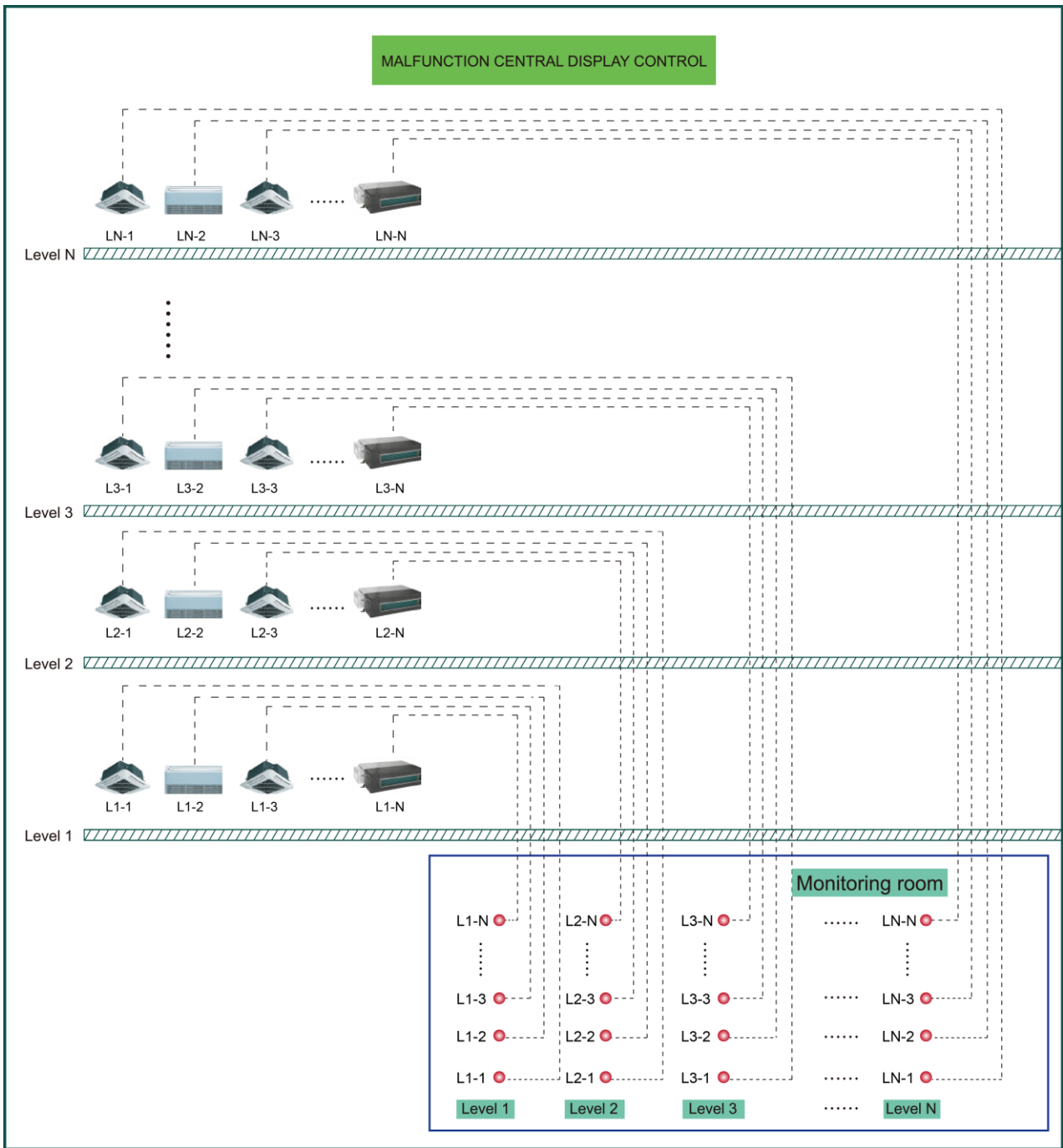

Figure 2-7-15 Malfunction output

(3) Setting method:

Do not need to set this function

**Notes:**

- ①. The interface voltage should be 220V AC intense current;
- ②. If malfunction light is connected, please make sure its power is not too big (it should be within 10W), otherwise, the relay on mainboard will be burnt.

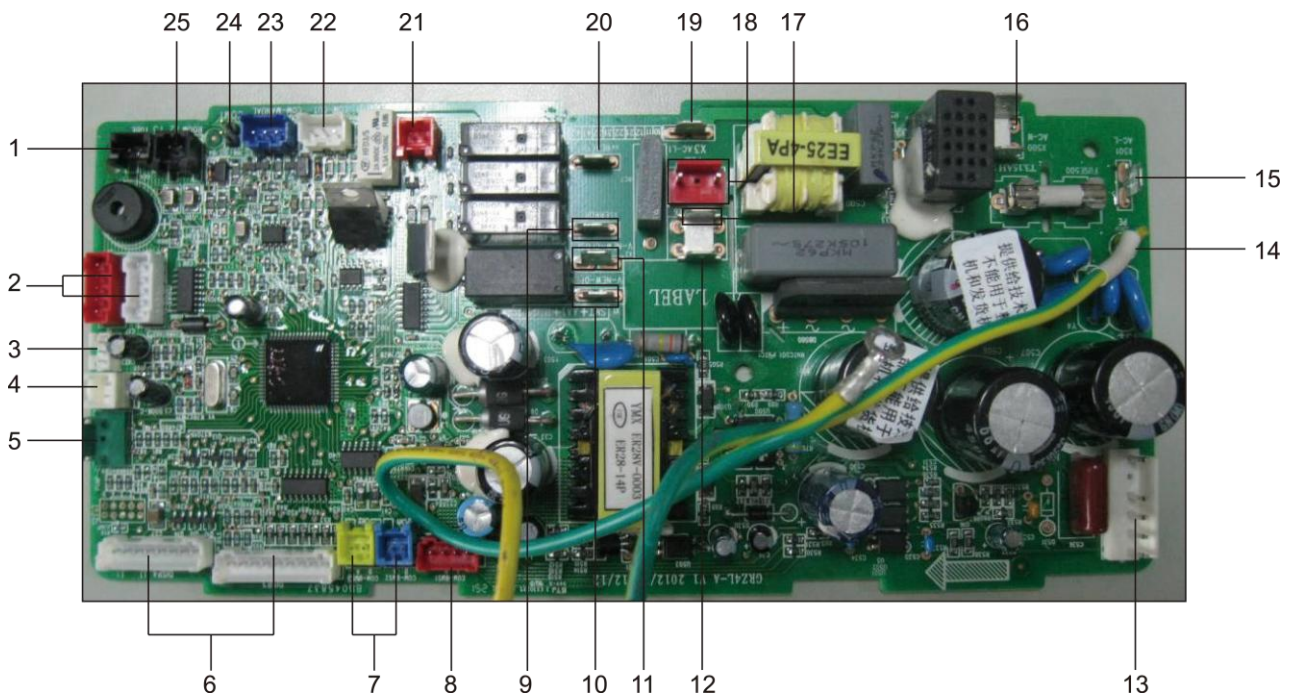

Figure 2-7-15

Table 2-7-4 Corresponding interfaces of mainboard

No.	Interface
1	Evaporator temperature sensor
2	Swing motor
3	Human sensitive
4	Door control
5	Full water detection
6	Interface of light board
7	Communication port of centralized controller
8	MOUDBUS interface
9	Interface of annunciator live wire
10	ON interface of fresh air valve
11	OFF interface of fresh air valve
12	Interface of annunciator neutral wire
13	Interface of DC motor
14	Mainboard grounding wire
15	Power live wire
16	Power neutral wire
17	Neutral wire of fresh air valve
18	Water pump interface
19	Live wire of fresh air valve
20	Interface of anion generator
21	Interface of auxiliary heating board
22	Interface of outdoor unit
23	Interface of wired controller
24	Monitor interface
25	Ambient temperature sensor

### 7.2.7 Reserved fresh air valve interface for duct type unit

For the reserved connection way of air valve performer, connect it to F, C, O of wiring board according to the wiring diagram. Connect the public port of air valve to F, connect CLOSE to C and connect OPEN to O.

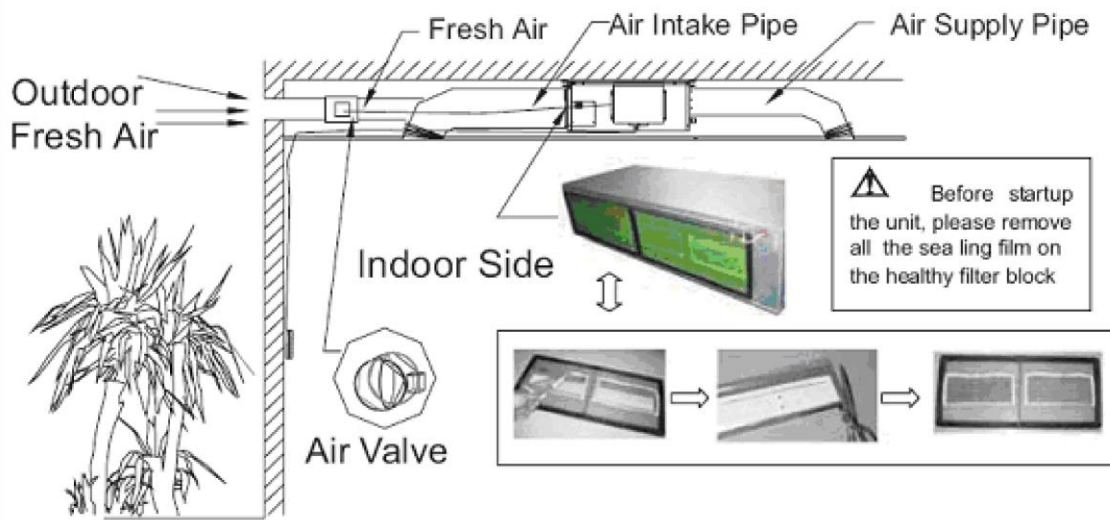

Figure 2-7-16

### 7.2.8 Interface of anion generator

For the cold plasma anion generator, connect the red line to HEALTH (X4) and the blue line to N2(X6) according to the principle circuit. The detector of cold plasma anion generator should be places at the air return. The distance between two detectors should be  $10\text{mm} \leq L \leq 25\text{mm}$ .

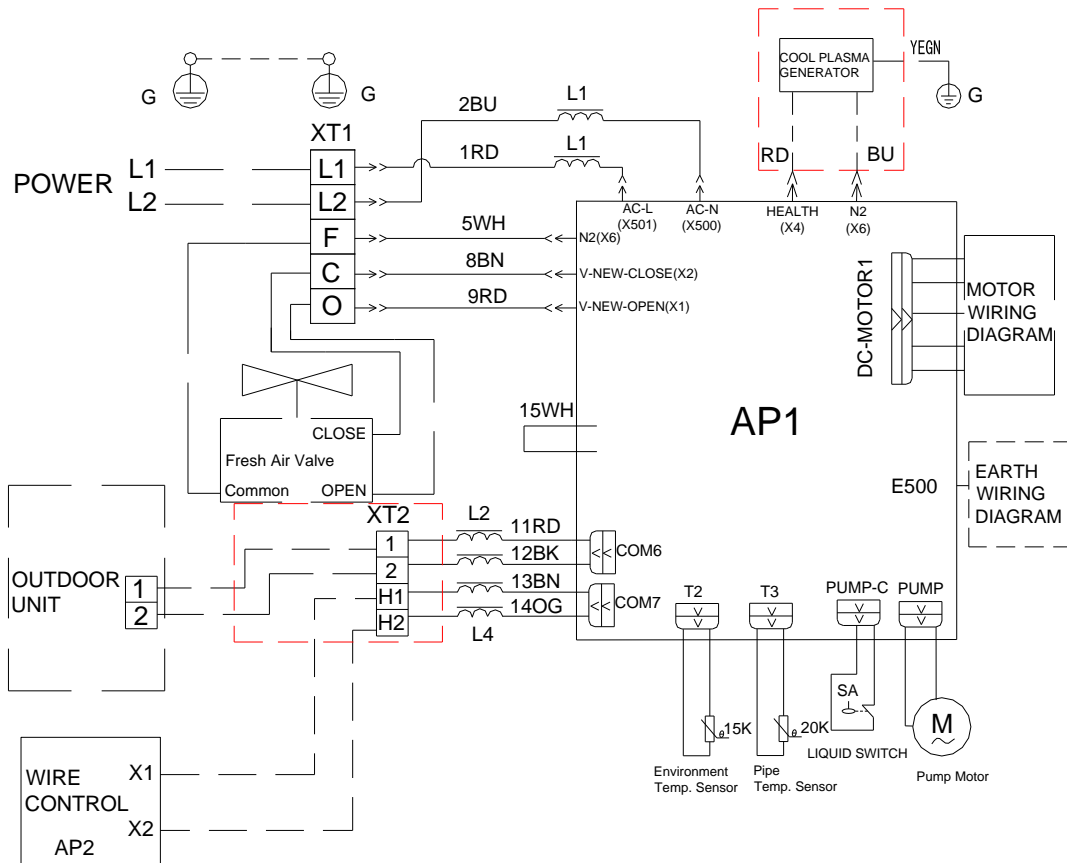

Figure 2-7-17

### 7.2.9 Chassis electric heating belt of outdoor unit is optional

When outdoor ambient temperature is very low, electric heating belt can be equipped on the chassis to prevent freezing of the chassis.

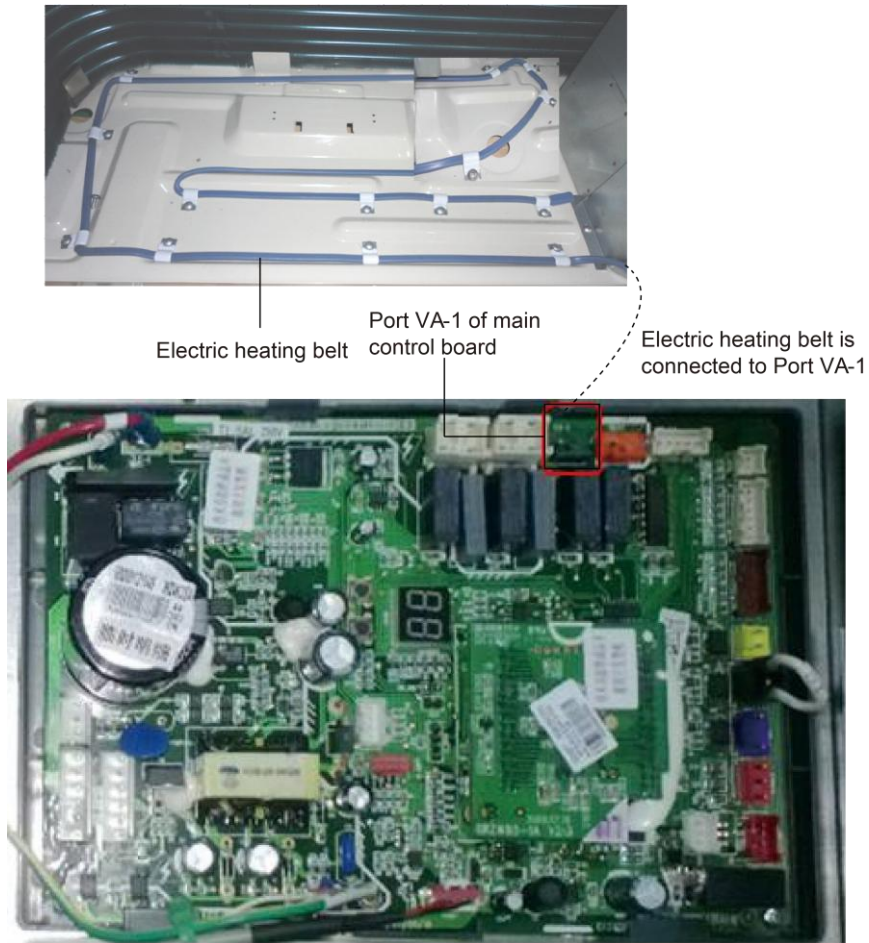

Figure 2-7-18

# INSTALLATION

# INSTALLATION

## 1 INDOOR UNIT INSTALLATION

### 1.1 Installation of Duct Type

#### 1.1.1 Before Installation

After receiving the machine, please check for any transport damage. If finding any surface or internal damage, please immediately report to the transport company or equipment company in writing.

After receiving the machine, please check the unit and accessories in reference to the packing list. Ensure that the model is correct and the machine is in good condition. Please also check if the specification and quantity of accessory parts are correct.

Determine the correct handling route and methods, thus to avoid damaging the unit or causing possible hazard. For the sake of protection and safety, it is suggested to move the unit with the packaging box. Even though it is not permitted to do like this under special occasions, do not remove the packaging box, thus to avoid loosening or falling during handling.

Confirm if the installing foundation is solid. When this unit is to be installed on the metal section of the building, make sure that the electrical insulation must comply with applicable standards.

Ensure that the place of installation is far from the area where the inflammable or explosive substances are stored, thus to avoid possible explosion or fire due to leakage.

#### 1.1.2 Installation Site

Ensure the top hanging piece has strong strength to withstand the weight of the unit.

The drainage pipe has convenient flow of water.

There is no obstacle blocking the return air inlet and exhaust outlet, so as to ensure sound air circulation.

The installation spaces required by the drawing must be ensured, so as to provide enough space for the service and maintenance.

The installation site must be far away from heat source, leakage of inflammable gas or smoke.

The indoor unit is of ceiling mount (indoor unit is hidden inside the ceiling).

The indoor and outdoor units, the power cable and the connecting electrical lines must be at least 1 meter from any TV set or radio. This is to avoid image interference or noise of the TV set or radio. (Even if the distance is 1 meter, noise can also exist if there is strong electric wave.)

#### 1.1.3 Caution for Installation

Generally, the unit is installed indoor on ceiling. For ceiling mounting, ensure that the hangers on ceiling have adequate strength to support the weight of the unit.

To meet the noise and vibration requirements, the unit shall be installed by using rubber pad (thickness  $\geq 20\text{mm}$ ) and rubber connector.

Insert a M10 expansion bolt into the hole. Drive a nail into the bolt. Refer to the profile dimensions drawing of the indoor unit for the distance between the holes. Refer to Figure 3-1-1 for the installation of the expansion bolt.

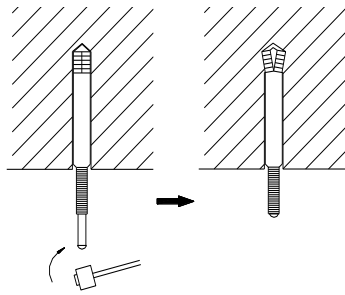

Figure 3-1-1

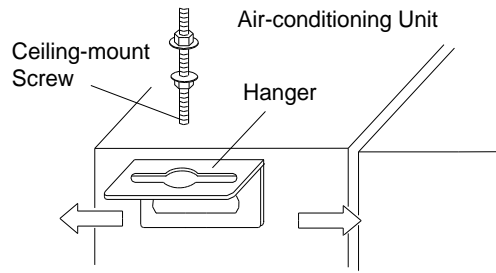

Figure 3-1-2

Install the hanger onto the indoor unit as Figure 3-1-2 shows.

Install the indoor unit at the ceiling as Figure Figure 3-1-3 shows.

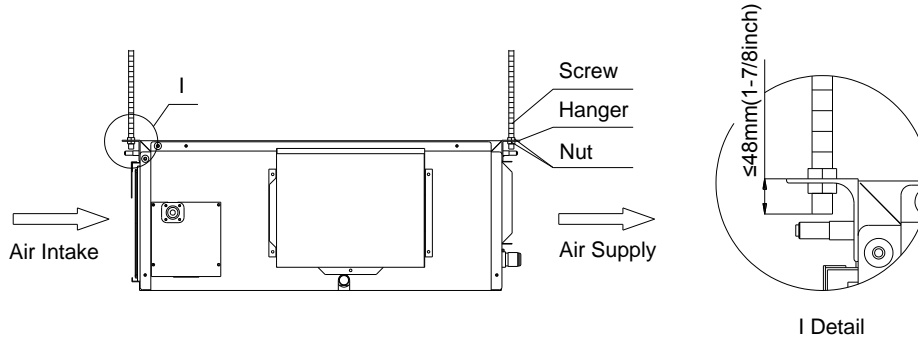

Figure 3-1-3

Precautions for unfavorable installation:

The preparation of all pipes (connecting pipes and drainage pipes) and cables (connecting lines of wire controller, indoor unit and outdoor unit) must be ready before the installation, so as to achieve smooth installation.

Drill an opening on the ceiling. Maybe it is required to support the ceiling to ensure the evenness of it and avoid the vibration of it. Consult with the user or a construction company for details.

In case the strength of ceiling is not enough, use angle iron sections to set up a beam support. Place the unit at the beam and fix it.

Level inspection of the indoor unit

After the indoor unit is installed, it is required to check the level of the whole unit. The unit must be placed horizontally, but the condensate pipe shall be installed obliquely, so as to facilitate the drainage of condensate.

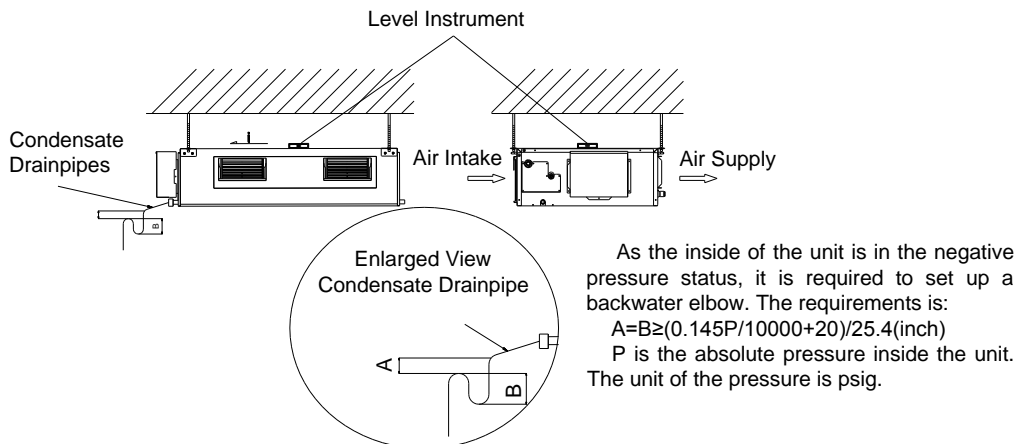
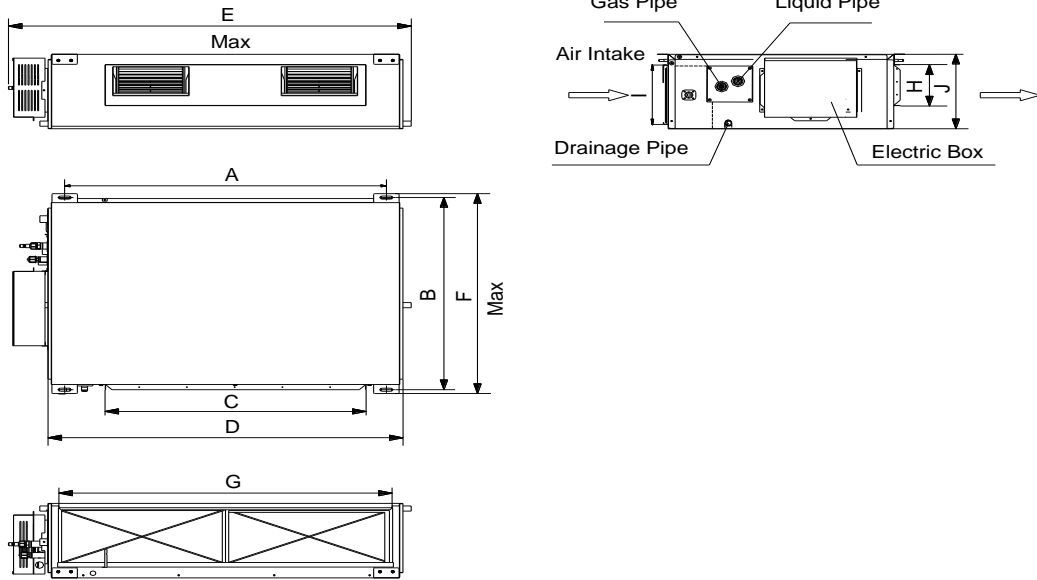

Figure 3-1-4

### 1.1.4 Dimension Data

For the units: GFH24S3GI, GFH24S3G1I



For the units: GFH36S3GI, GFH36S3G1I, GFH42S3GI, GFH42S3G1I, GFH48S3GI, GFH48S3G1I

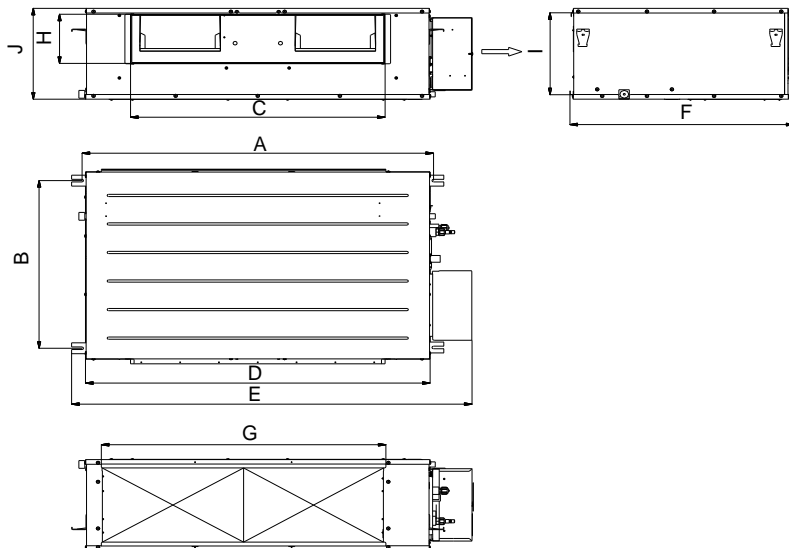

For the units: GFH60S3GI, GFH60S3G1I

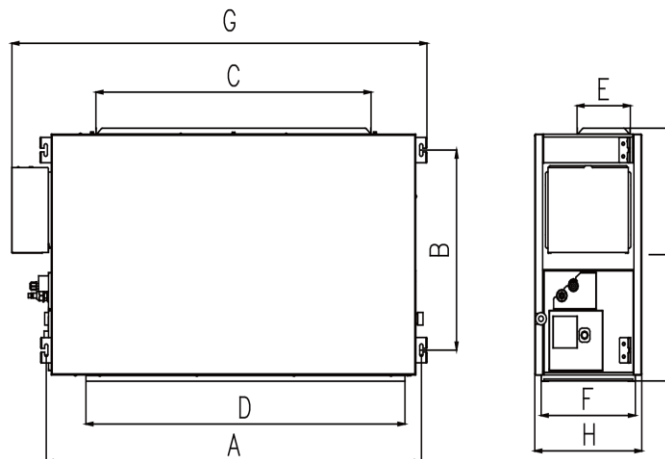

Figure 3-1-5



Table 3-1-1

Item Model	A	B	C	D	E	F	G	H	I	J
GFH24S3GI GFH24S3G1I	1010	750	820	1115	1225	775	980	160	230	290
GFH36S3GI GFH36S3G1I	1175	645	850	1150	1340	750	950	190	315	350
GFH42S3GI GFH42S3G1I										
GFH48S3GI GFH48S3G1I										
GFH60S3GI GFH60S3G1I	1350	630	990	1150	190	340	1500	390	800	--

Table 3-1-2 Installation Accessories List for Duct-type Indoor Unit

Name & Shape	QTY	Notes
Installation and Operating Instructions	1	
Insulation materials for gas pipe	1	Used for gas pipe connector on indoor unit.
Insulation materials for liquid pipe	1	Used for liquid pipe connector on indoor unit.
Insulation materials for drainage pipe	2	Used for wrapping the condensate pipe and rubber plug.
Nut	1	To connect liquid pipe.
Nut	1	To connect gas pipe.
Nut M6 with gasket	8	Use for fixing the hanger hook.
Nut M10 with gasket	4	Use for fixing the hanger hook.
Nut M10	4	4 sets, used for ceiling mounting of the indoor unit.
spring gasket	4	
Hook	4	Used for ceiling mounting of the indoor unit.
Wired controller	1	
Screw M4	2	To fix the base plate of wired controller and installation hole of the wall together.

### 1.1.5 Installation Clearance Data

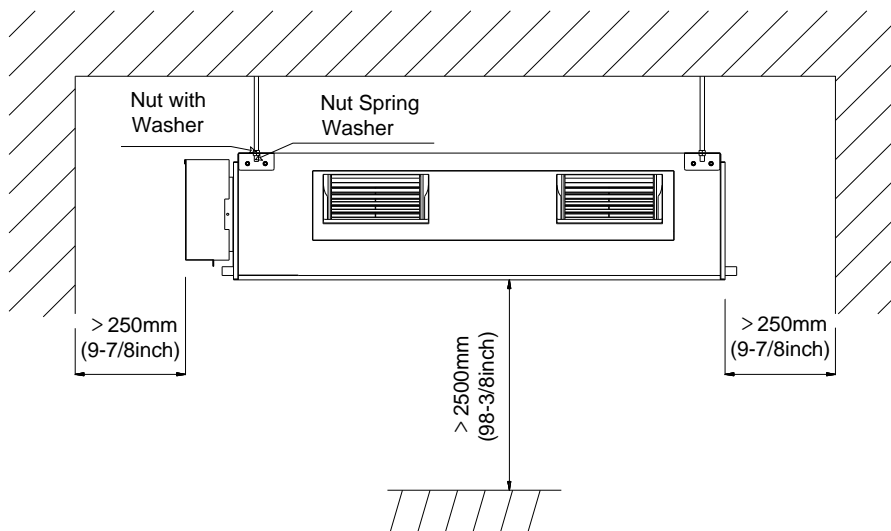



Figure 3-1-6

Warning: The height of installation for the indoor unit should be 2.5m above.

### 1.1.6 Drain Piping Work

Installation of Drainage Pipeline:

**CAUTION!**

Install the drain hose in accordance with the instructions in this installation manual and keep the area warm enough to prevent condensation. Problems with the piping may lead to water leaks.

- (1) Install the drain hose with downward gradient (1/50 to 1/100) and no risers or traps are used for the hose. (Figure 3-1-7)
- (2) Be sure there is no crack or leak on the drain hose to avoid the formation of air pocket. (Figure 3-1-7)
- (3) When the hose is long, install supporters. (Figure 3-1-8)
- (4) Always use the drain hose which has been insulated properly.

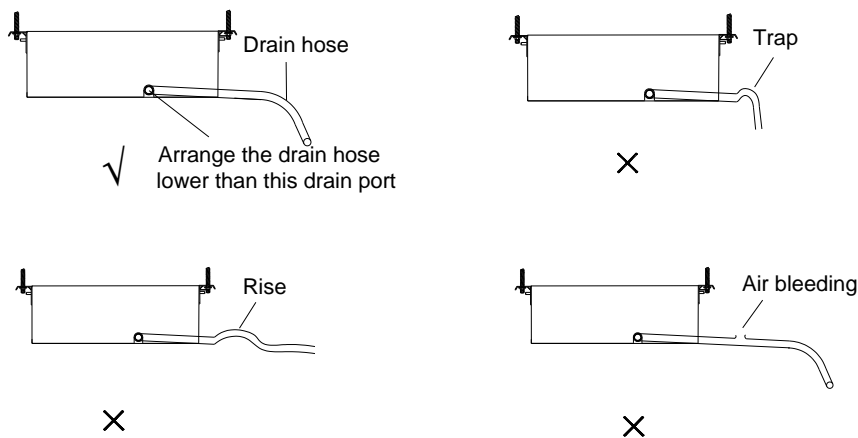

Figure 3-1-7

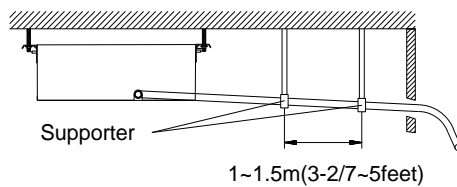
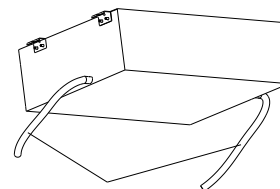

Figure 3-1-8



Drain hose  
Figure 3-1-9

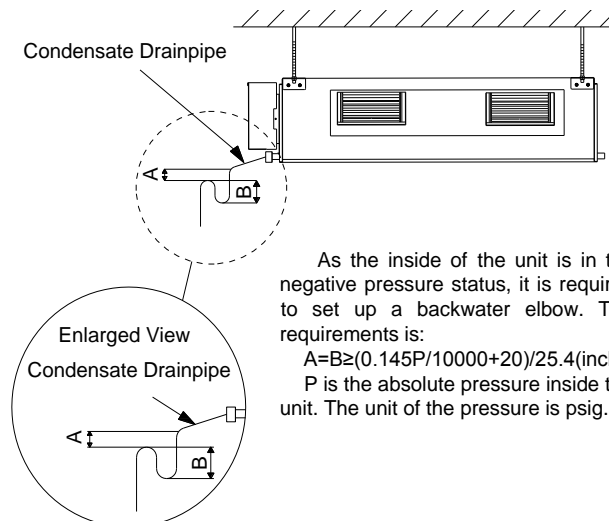

Figure 3-1-10

(5) Use a suitable drain hose, and see Table 3-2-4 for its size.

(6) There is a drain port on both the left and right sides. Select the drain port to match the local conditions. (Figure 3-1-9)

(7) When the unit is shipped from the factory, the drain port is defaulted to be the one on the left side (electric box side), the port on right side has been plugged.

(8) When using the drain port on the right side of the unit, reinstall the drain cap to the left side drain port. (Figure 3-1-11)

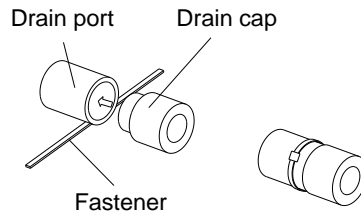

Figure 3-1-11

<b>CAUTION!</b>
<p>Always check that the drain cap is installed to the unused drain port and is fastened with the nylon fastener. If the drain cap is not installed, or is not sufficiently fastened by the nylon fastener, water may drip during the cooling operation.</p>

(9) Be sure to insulate where the drain port and the drain hose is connected. (Figure 3-1-12 )

(10) The unused drain port also should be insulated properly. ( Figure 3-1-13)

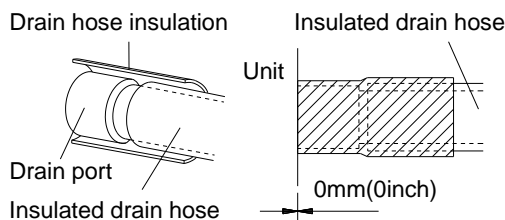

Figure 3-1-12

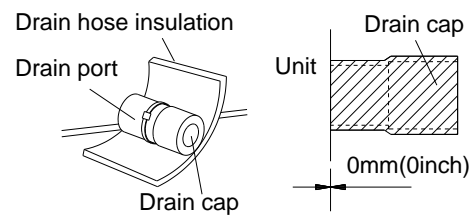

Figure 3-1-13

(11) There is adhesive on one side of the insulation so that after removing the protective paper over it the insulation can be directly attached to the drain hose.

(12) Considerations for the unit with the condensate pump:

1) For the unit with the condensate pump, only one drain port at the side close to the electric box is prepared and only through it the drain hose can be connected.

2) See table 3 for the size of the drain port of the unit with the condensate pump, which is different from that of the unit without the condensate pump.

3) For the unit with the condensate pump, two drain ports at the bottom are defaulted to be factory plugged with drain caps. After the installation of the drain hose, these two drain ports also need to be insulated properly with the same way aforementioned.

4) The drain hose for the unit with the condensate pump should be arranged as shown in the figure below.

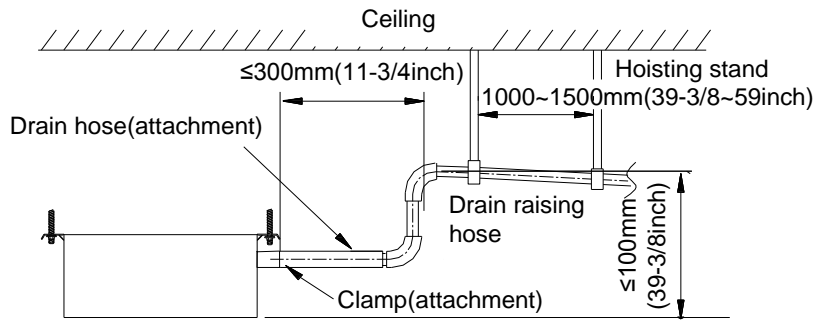

Figure 3-1-14

a. The vertical height of the drain hose should be 75mm or less so that it is unnecessary for the drain port to withstand additional force.

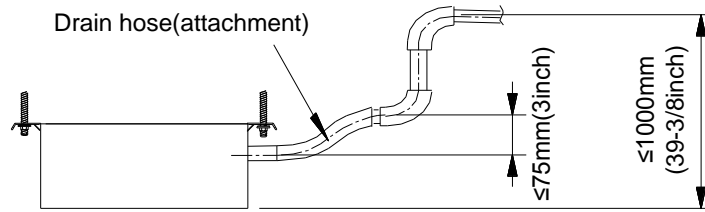

Figure 3-1-15

b. When multiple drain hoses are used, their installation should be performed as shown in the figure below.

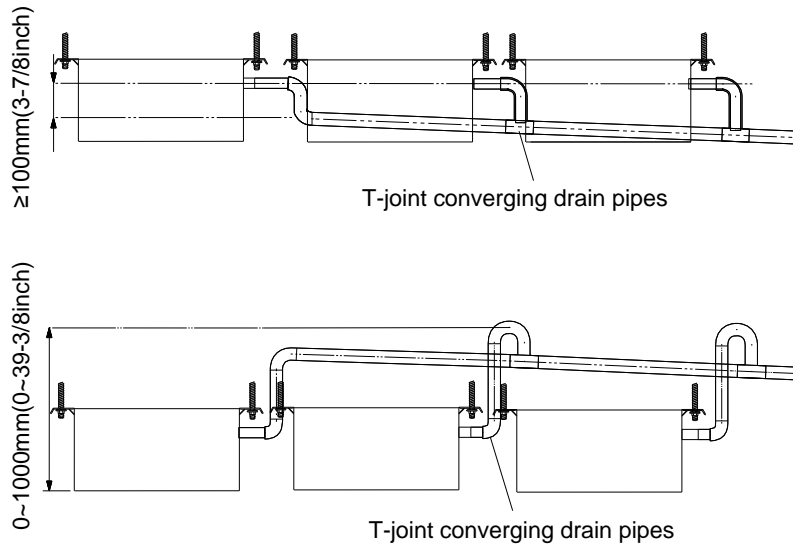

Figure 3-1-16

### 1.1.7 Installation of air duct

Dimensions of the Supply Air Outlet/Return Air Inlet

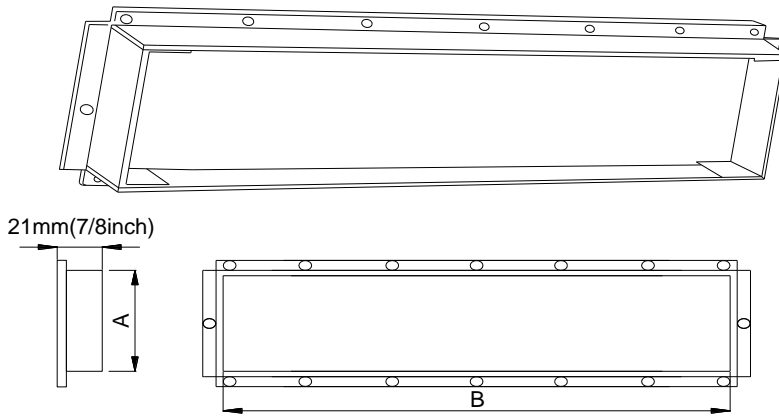

Figure 3-1-17 Supply Air Outlet

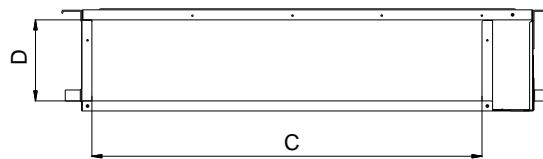

Figure 3-1-18 Return Air Inlet

Table 3-1-3

Model	Item	Supply Air Outlet		Return Air Inlet	
		A	B	C	D
GFH24S3GI GFH24S3G1I		158	818	950	206
GFH36S3GI GFH36S3G1I		190	850	941	286
GFH42S3GI GFH42S3G1I		190	850	941	286
GFH48S3GI GFH48S3G1I		190	850	941	286
GFH60S3GI GFH60S3G1I		190	990	1108	288

### 1.1.8 Installation of the Supply Air Duct

(1) Installation of the Rectangular Duct.

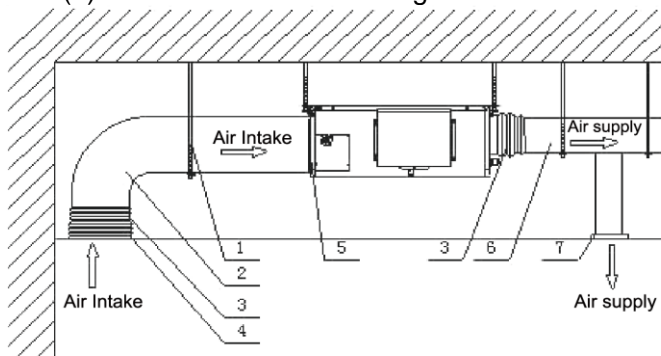

No.	Name	No.	Name
1	Hanger	5	Filter
2	Air Intake Pipe	6	Main Air Supply Pipe
3	Canvas Air Pipe	7	Air Supply Outlet
4	Air Intake		

Figure 3-1-19

 <b>CAUTION!</b>	
①.	The maximum length of the duct means the maximum length of the supply air duct plus the maximum length of the return air duct.
②.	The duct is rectangular and connected with the air inlet/outlet of the indoor unit. Among all supply air outlets, at least one should be kept open.

(2) The default installation location of the rectangular flange is at the back and the return air cover plate is at the bottom, as shown in Figure 3-1-20.

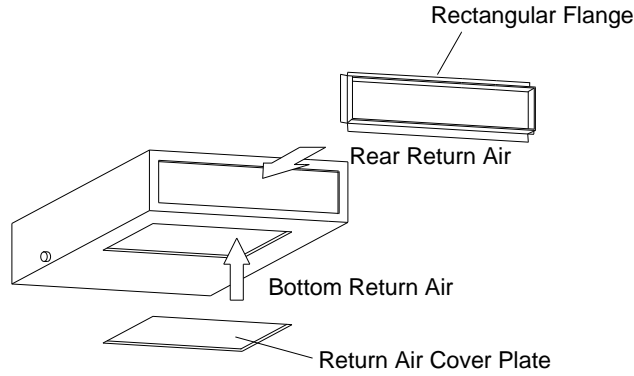

Figure 3-1-20

(3) If the bottom return air is desired, just change the place of the rectangular flange and the return air cover plate.

(4) Connect one end of the return air duct to the return air outlet of the unit by rivets and the other to the return air louver. For the sake of the convenience to freely adjust the height, a cutting of canvas duct will be helpful, which can be reinforced and folded by 8# iron wire

(5) More noise is likely to be produced in the bottom return air mode than the backward return air mode, so it is suggested to install a silencer and a static pressure box to minimize the noise.

(6) The installation method can be chosen with considering the conditions of the building and maintenance etc., as shown in Figure 3-1-21.

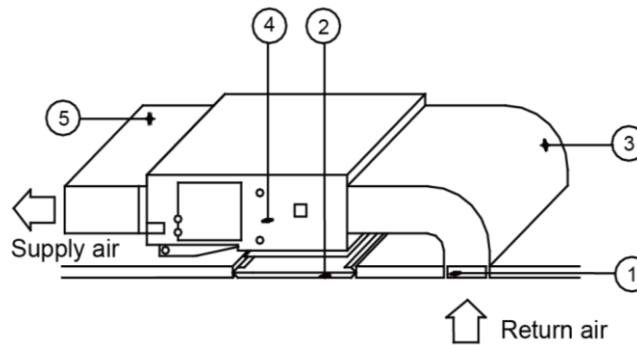

Install the return air duct(b)

Figure 3-1-21

Table 3-1-4 Installation of the return air duct

No.	Name	No.	Name
1	Return Air Inlet (with filter)	4	Indoor unit
2	Grille	5	Supply Air Duct
3	Return Air Duct		

## 1.2 Installation of Cassette Type

### 1.2.1 Before Installation

After receiving the machine, please check for any transport damage. If finding any surface or internal damage, please immediately report to the transport company or equipment company in writing.

After receiving the machine, please check the unit and accessories in reference to the packing list. Ensure that the model is correct and the machine is in good condition. Please also check if the specification and quantity of accessory parts are correct.

Determine the correct handling route and methods, thus to avoid damaging the unit or causing possible hazard. For the sake of protection and safety, it is suggested to move the unit with the packaging box. Even though it is not permitted to do like this under special occasions, do not remove the packaging box, thus to avoid loosening or falling during handling.

Confirm if the installing foundation is solid. When this unit is to be installed on the metal section of the building, make sure that the electrical insulation must comply with applicable standards.

Ensure that the place of installation is far from the area where the inflammable or explosive substances are stored, thus to avoid possible explosion or fire due to leakage.

### 1.2.2 Installation Site

Select an installation site where the following conditions are fulfilled and that meets your customer's approval.

Obstruct should be put away from the intake or outlet vent of the indoor unit so that the airflow can be blown through all the room.

Make sure that the installation meets the requirement of the schematic diagram of installation spaces.

Select the place where can stand 4 times of the weight of the indoor unit and would not increase the operating noise and vibration.

The horizontality of the installation place should be guaranteed.

Select the place where is easy to drain out the condensate water, and connect with outdoor unit.

Make sure that there are enough space for care and maintenance, and the height fall between the indoor unit and ground is above 1800mm (6ft).

When installing the suspension bolt, check if the installation place can stand 4 times of the weight of the unit. If not, reinforce it before installation.



**Note:** There will be large amount of greasy dirt accumulated on the fan, heat exchanger and water pump located in the dining room and kitchen, which would reduce the capacity of the heater exchanger, lead to leakage and abnormal operation of the water pump.

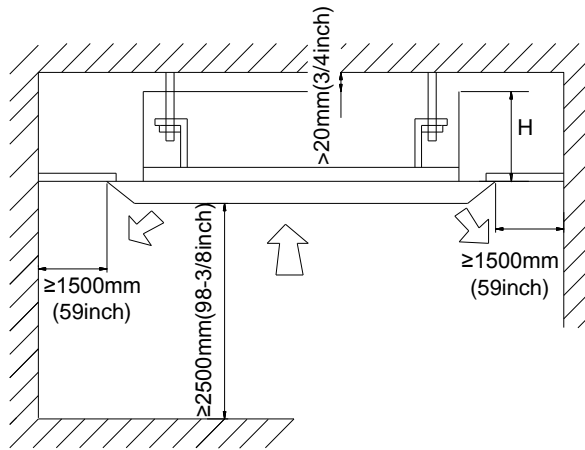

Figure 3-1-24

Table 3-1-5

Models	H mm (inch)
GKH24S3GI	260(10-1/4)
GKH36S3GI	340(13-3/8)
GKH42S3GI	340(13-3/8)
GKH48S3GI	320(12-5/8)

### 1.2.3 Installing the Main Body Unit

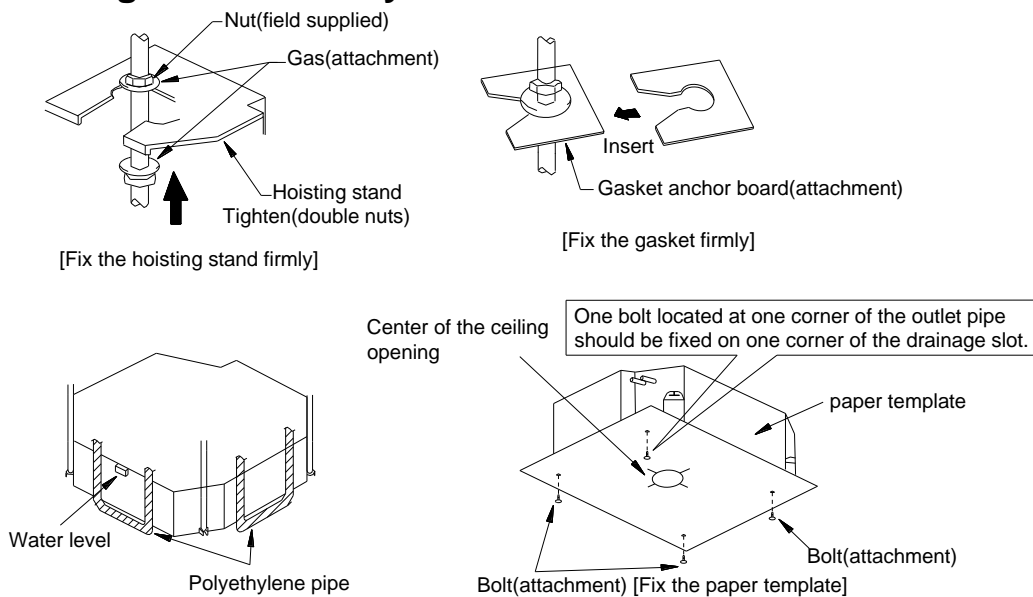

Figure 3-1-39

- (1) Install the hoisting stand on the hoisting screw by using nuts and gaskets at both the upper and lower sides of the hoisting stand. To prevent the gasket from breaking off, a gasket anchor board can be helpful.
- (2) Install the paper template on the unit, and fix the drain pipe at the outlet vent.
- (3) Adjust the unit to the best position.
- (4) Check if the unit is installed horizontally at four directions. If not, the water pump and the float switch would function improperly and even lead to water leakage.
- (5) Remove the gasket anchor board and tighten the nut remained.
- (6) Remove the paper template.



### 1.2.4 Installing the Suspension Bolts

(1) Using the installation template, drill holes for bolts (four holes) (Figure 3-1-40).

(2) Install the bolts to the ceiling at a place strong enough to hang the unit. Mark the bolt positions from the installation template. With a concrete drill, drill for 12.7mm (1/2inch) diameter holes (Figure 3-1-41).

(3) Insert the anchor bolts into the drilled holes, and drive the pins completely into the anchor bolts with a hammer (Figure 3-1-42).

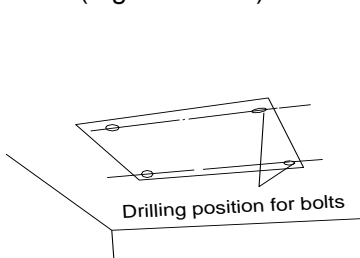

Figure 3-1-40

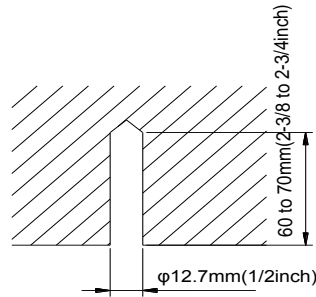

Figure 3-1-41

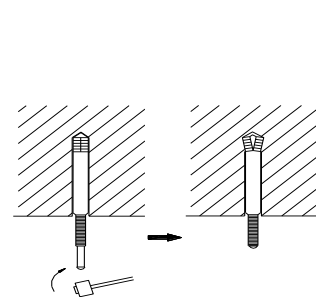

Figure 3-1-42

### 1.2.5 Leveling

The water level test must be done after installing the indoor unit to make the unit is horizontal, as shown below.

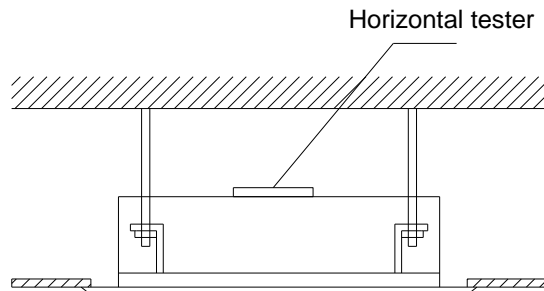

Figure 3-1-43

### 1.2.6 The Panel Installation

(1) See the figure below for the relationship of the front panel and the connecting pipe.

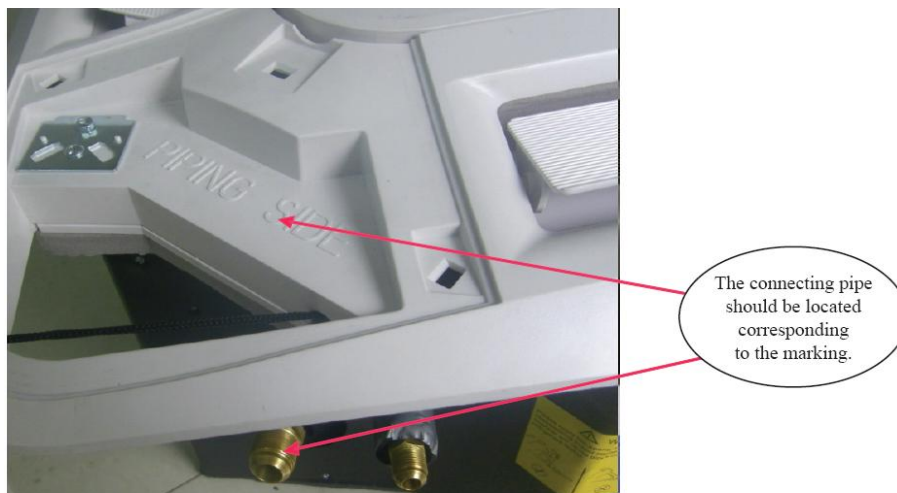

Figure 3-1-44

- (2) Place the panel at the unit, and latch the hooks beside and opposite the swing flap motor.
- (3) Latch other two hooks.
- (4) Tighten four hexagonal screws under the latches about 15mm (5/8inch).
- (5) Adjust the panel along the direction indicated by the arrow as shown in Figure 3-1-45.
- (6) Tighten the screws until the thickness of the sealing material between the panel and the indoor unit reduces to 5~8mm (1/4~3/8inch).

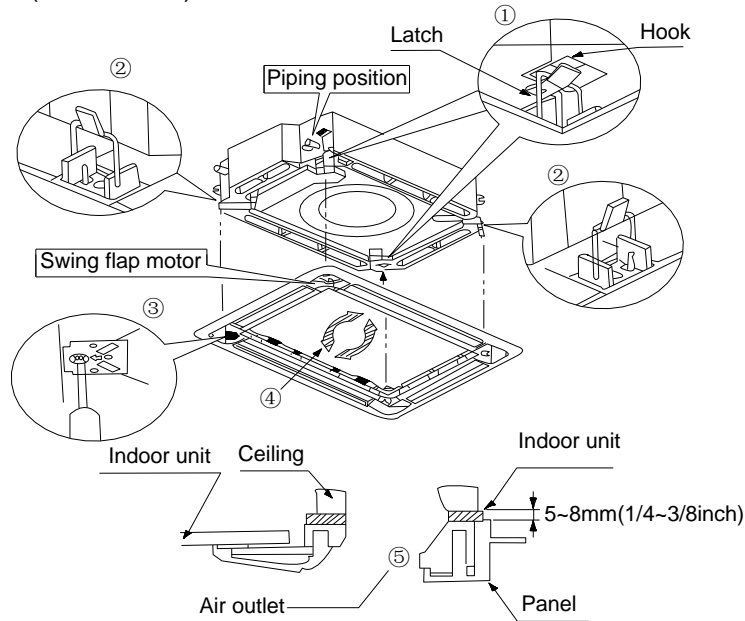

Figure 3-1-45

- (7) Improper screwing of the screws may cause the troubles shown in Figure 3-1-46.

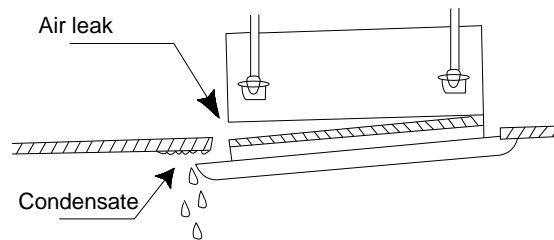

Figure 3-1-46

- (8) If gap still exists between ceiling and decoration panel after tightening the screws, readjust the height of the indoor unit (Figure 3-1-47).

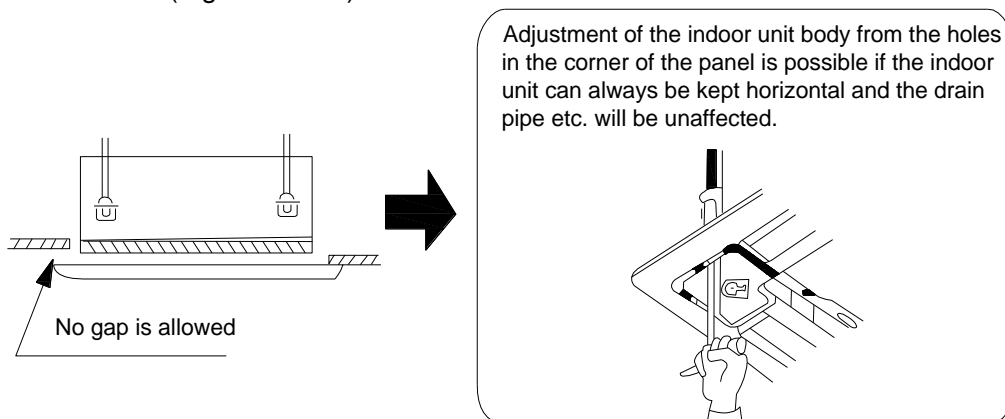

Figure 3-1-47

(9) Wire the swing flap motor as shown in Figure 3-1-48.

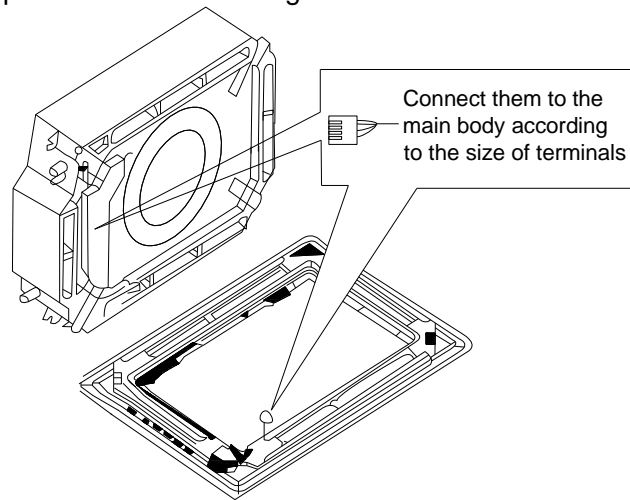

Figure 3-1-48

### 1.2.7 Dimension Data

For the units: 24k~48k

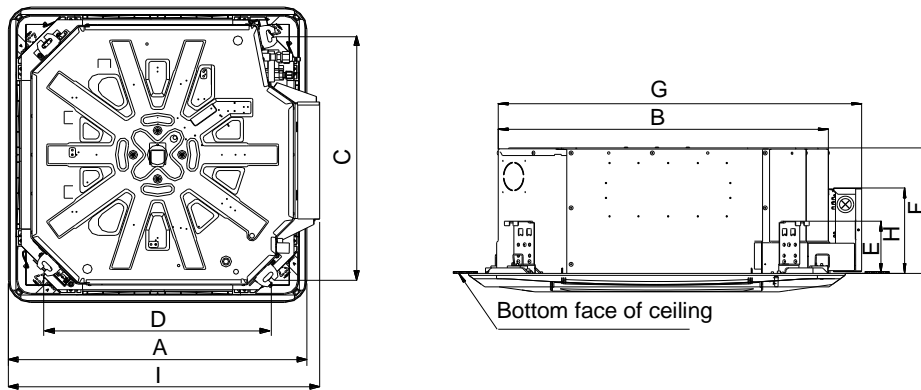

Table 3-1-49

Item	A	B	C	D	E	F
Model						
GKH24S3GI	950	840	770	680	134	240
GKH36S3GI	950	840	770	680	134	290
GKH42S3GI						
GKH48S3GI	1040	910	842	788	170	290

### 1.2.8 Installation of Drain Piping

(1) Keep piping as short as possible and slope it downwards at a gradient of at least 1/100 so that air may not remain trapped inside the pipe.

(2) Keep pipe size equal to or greater than that of the connecting pipe.

(3) Install the drain piping as shown and take measures against condensation. Improperly rigged piping could lead to leaks and eventually wet furniture and belongings.

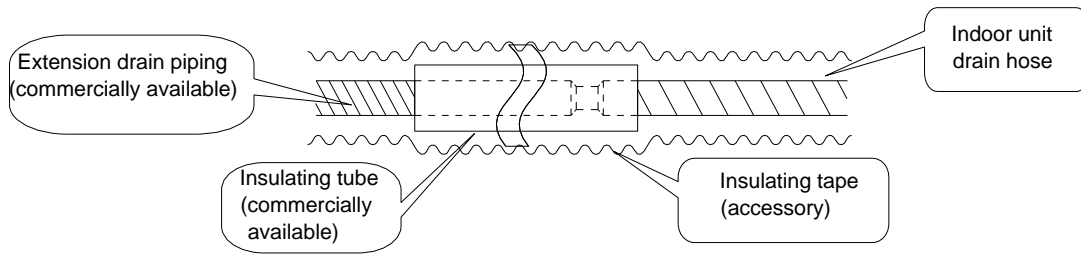

Figure 3-1-50

### 1.2.9 Installing the Drain Pipes

- (1) Insert the drain pipe to the drain outlet of the unit and then tighten the clamp securely with tape.
- (2) Connect the extension drain pipe to the drain pipe and then tighten the clamp with tape.

<p>During the installation, distance from soft drain pipe to the gasket is <math>15 \pm 3\text{mm}</math> when the bolt is tightened. It is not allowed to apply PVC or other related glue in the joints of two ends of drain pipe.</p> <ol style="list-style-type: none"> <li>①. Metal clamp (accessory)</li> <li>②. Insulation sponge (accessory)</li> </ol>	<p>Insulate the pipe clamp and the drain hose using heat insulation sponge.</p> <ol style="list-style-type: none"> <li>①. Metal clamp</li> <li>②. Drain hose (accessory)</li> <li>③. Grey tape (accessory)</li> </ol>

(3) When unifying multiple drain pipes, install the pipes as Figure 3-1-51. Select converging drain pipes whose gauge is suitable for the operating capacity of the unit (take the cassette type unit for example).

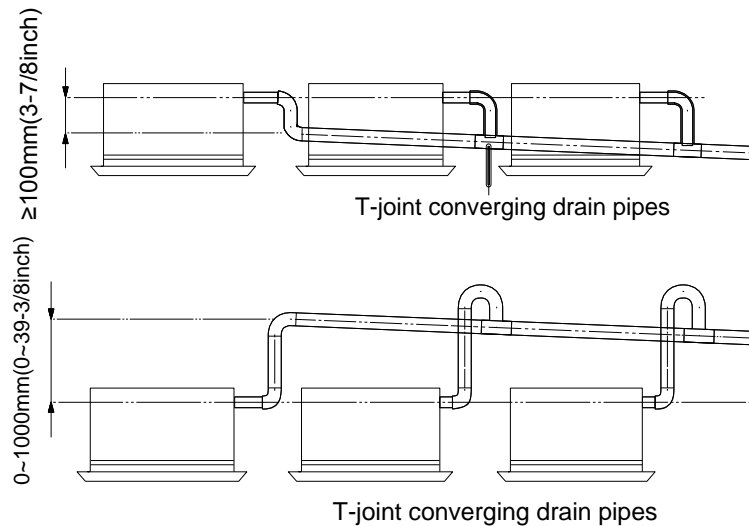

Figure 3-1-51

(4) When the drain hose cannot keep a sufficient gradient, it is necessary to fit a riser pipe (field supplied) to it.

(5) If the air flow of indoor unit is high, this might cause negative pressure and result in return suction of outdoor air. Therefore, U-type water trap shall be designed on the drainage side of each indoor unit (Figure 3-1-52).

- (6) Install one water trap for each unit.
- (7) Installation of water trap shall consider easy cleaning in the future.

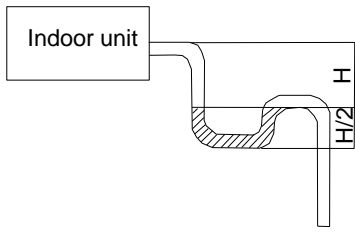

Figure 3-1-52

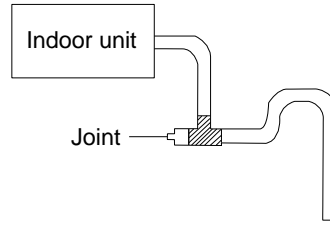

Figure 3-1-53

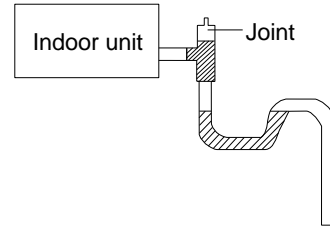

Figure 3-1-54

(8) Connection of drainage branch pipe to the standpipe or horizontal pipe of drainage main pipe.

(9) The horizontal pipe cannot be connected to the vertical pipe at a same height. It can be connected in a manner as shown below:

NO.1: Attach the 3-way connection of the drainage pipe joint as shown in Figure 3-1-55.

NO.2: Attach the drain elbow as shown in Figure 3-1-56.

NO.3: Attach the horizontal pipe as shown in Figure 3-1-57.

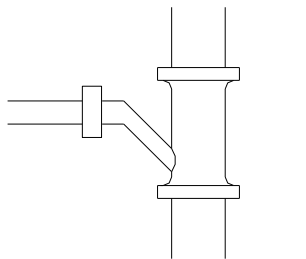

3-way connection of drainage pipe joint

Figure 3-1-55

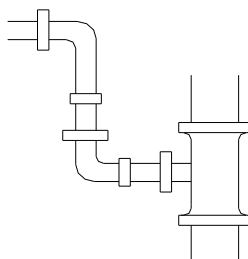

Connection of drain elbow

Figure 3-1-56

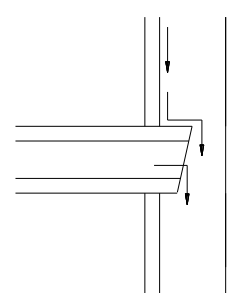

Connection of horizontal pipe

Figure 3-1-57

### 1.2.10 Precautions When Doing Riser Piping Work

(1) Make sure that heat insulation work is executed on the following 2 spots to prevent any possible water leakage due to dew condensation.

- ◆ Connect the drain hose to the drain lift pipe, and insulate them.
- ◆ Connect the drain hose to the drain outlet on the indoor unit, and tighten it with the clamp.

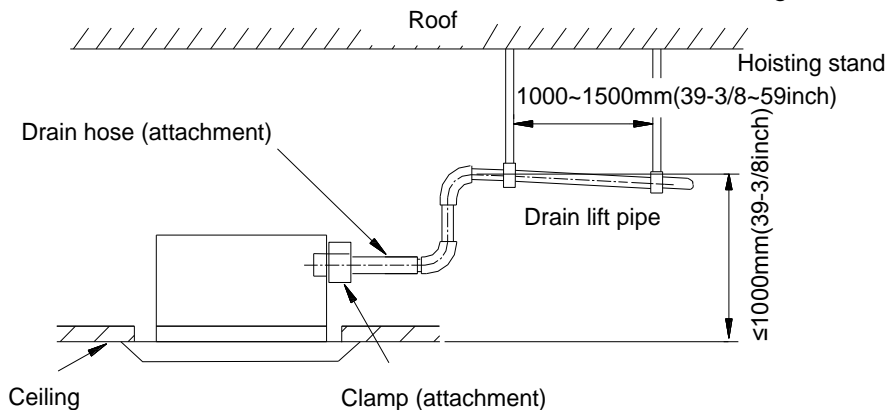

Figure 3-1-58

(2) Secure a downward gradient of 1/100 or more for the drain pipe. To accomplish this mount supporting brackets at an interval of 1~1.5m (3-2/7~5feet).

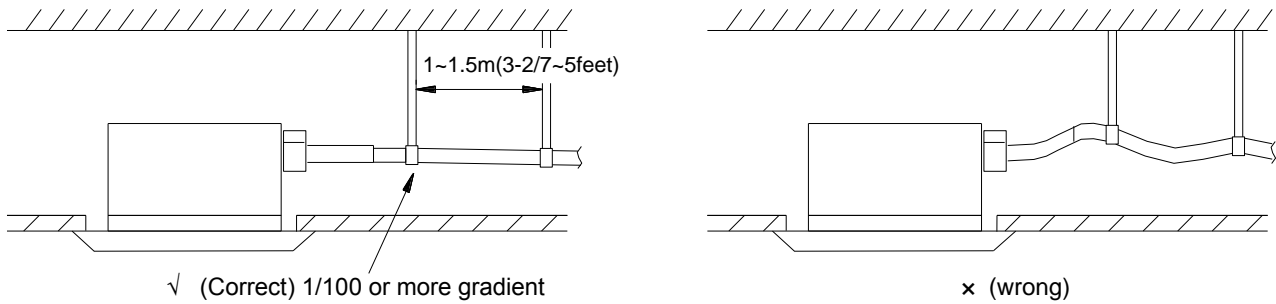

Figure 3-1-59

### 1.2.11 Testing of Drain Piping

After piping work is finished, check if drainage flows smoothly. Shown in the Figure 3-1-61, Add approximately 1liter of water slowly into the drain pan and check drainage flow during COOL running.

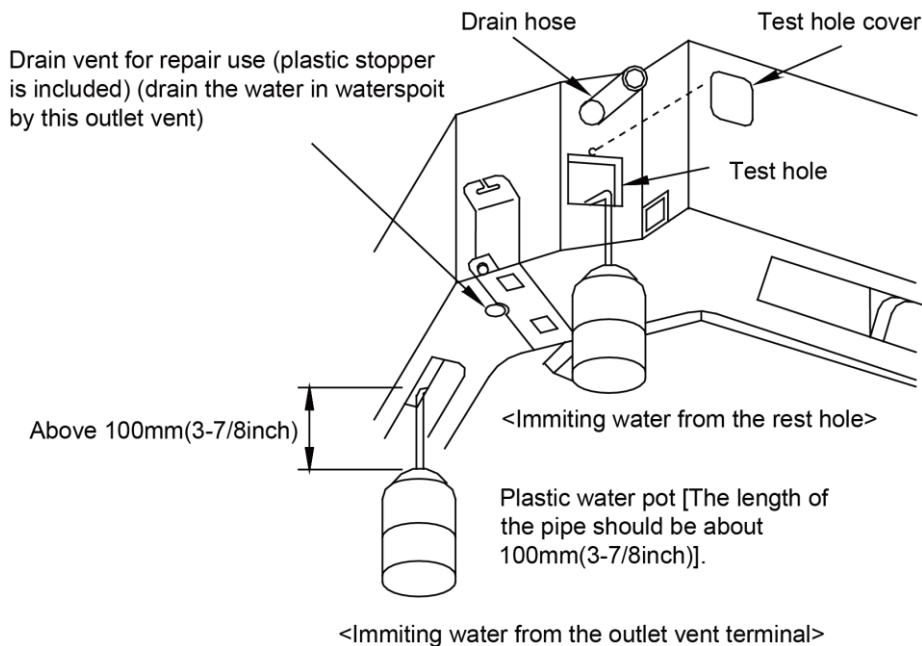

Figure 3-1-60

## 2 OUTDOOR UNIT INSTALLATION

### 2.1 Before Installation

After receiving the machine, please check for any transport damage. If finding any surface or internal damage, please immediately report to the transport company or equipment company in writing.

After receiving the machine, please check the unit and accessories in reference to the packing list. Ensure that the model is correct and the machine is in good condition. Please also check if the specification and quantity of accessory parts are correct.

Determine the correct handling route and methods, thus to avoid damaging the unit or causing possible hazard. For the sake of protection and safety, it is suggested to move the unit with the packaging box. Even though it is not permitted to do like this under special occasions, do not remove the packaging box, thus to avoid loosening or falling during handling.

Confirm if the installing foundation is solid. When this unit is to be installed on the metal section of the building, make sure that the electrical insulation must comply with applicable standards.

Ensure that the place of installation is far from the area where the inflammable or explosive substances are stored, thus to avoid possible explosion or fire due to leakage.

## 2.2 Installation Site

 <b>WARNING</b>
①. Install the unit where it will not be tilted by more than 5°.
②. During installation, if the outdoor unit has to be exposed to strong wind, it must be fixed securely.

If possible, do not install the unit where it will be exposed to direct sunlight. (If necessary, install a blind that does not interfere with the air flow.)

(1) Install the outdoor unit in a place where it will be free from being dirty or getting wet by rain as much as possible.

(2) Install the outdoor unit where it is convenient to connect with the indoor unit.

(3) Install the outdoor unit where the condensate water can be drained out freely during heating operation.

(4) Do not place animals and plants in the path of the warm air.

(5) Take the air conditioner weight into account and select a place where noise and vibration are small.

(6) Install the outdoor unit where is capable of withstanding the weight of the unit and generates as less noise and vibration as possible.

(7) Provide the space shown in Figure 3-2-1, so that the air flow is not blocked. Also for efficient operation, leave three of four directions of peripheral constructions open.

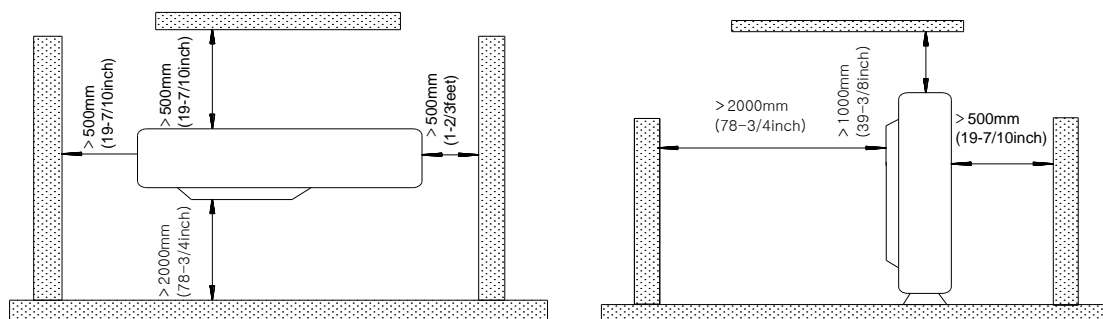

Figure 3-2-1

## 2.3 Caution for Installation

The outdoor unit shall be so installed that the air discharged out of the outdoor unit will not flow back and that enough space shall be maintained around the machine for repair;

The installing position shall be in good ventilation, so that the machine can breathe and exhaust enough air. Ensure that there is no obstruction at the inlet and outlet of the machine. If any, please remove the obstructions blocking the air inlet and outlet.

If the outdoor unit is installed on concrete or solid ground, it shall be fixed by using M10 bolts and nuts. And ensure that the machine is kept vertical and horizontal.

The outdoor unit must be lifted by using the designated lift hole. During lifting, take care to protect the air conditioner and avoid knocking the metal parts, thus to prevent rusting in the future.

To meet the noise and vibration requirements, the outdoor unit shall be installed by using rubber

damping pad or spring damper.

To install the drainage pipe, please insert the drainage joint to the drainage hole on the outdoor chassis and connect a drainage pipe on the drainage joint. (The installing height of outdoor unit shall be at least 5cm if drainage joint is to be used).

To insert the pipe through the wall, the wall-cross tube must be installed.

The installing dimension shall comply with the installation requirements in these instructions. The outdoor unit must be fixed at the installing position.

The installation shall be done by specialist technicians.

## 2.4 Dimension Data

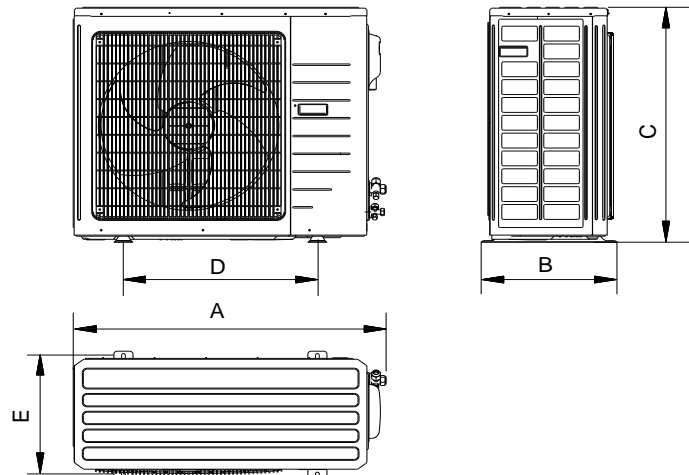

Figure 3-2-2

Table 3-2-1

Unit: mm

Model \ Item	A	B	C	D	E
GUHD24NS3GO	980	425	790	610	390
GUHD36NS3GO	1105	440	1100	630	400
GUHD42NS3GO					
GUHD48NS3GO	1085	425	1365	620	395
GUHD60NS3GO					

# 3 REFRIGERATION PIPING WORK

## 3.1 Refrigeration Piping Work Procedures and Caution in Connecting

### 3.1.1 Flare Processing

- (1) Cut the connection pipe with the pipe cutter and remove the burrs.
- (2) Hold the pipe downward to prevent cuttings from entering the pipe.
- (3) Remove the flare nuts at the stop valve of the outdoor unit and inside the accessory bag of the indoor unit, then insert them to the connection pipe, after that, flare the connection pipe with a flaring tool.



(4) Check if the flare part is spread evenly and there are no cracks (see Figure 3-2-3).

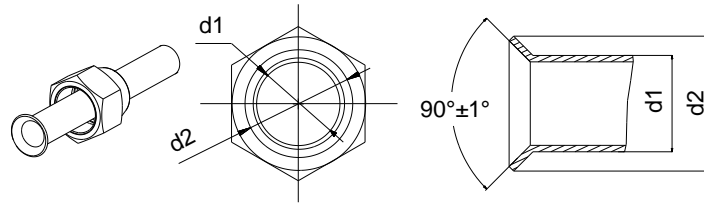

Figure 3-2-3

### 3.1.2 Bending Pipes

(1) The pipes are shaped by your hands. Be careful not to collapse them.

(2) Do not bend the pipes in an angle more than 90°.

(3) When pipes are repeatedly bent or stretched, the material will harden, making it difficult to bend or stretch them any more. Do not bend or stretch the pipes more than three times.

(4) When bending the pipe, do not bend it as is. The pipe will be collapsed. In this case, cut the heat insulating pipe with a sharp cutter as shown in Figure 3-2-4, and bend it after exposing the pipe. After bending the pipe as you want, be sure to put the heat insulating pipe back on the pipe, and secure it with tape.

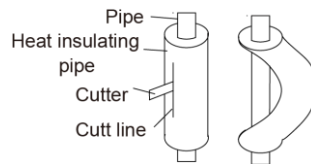



Figure 3-2-4

 <b>CAUTION!</b>
①. To prevent breaking of the pipe, avoid sharp bends. Bend the pipe with a radius of curvature of 150mm or over.
②. If the pipe is bent repeatedly at the same place, it will break.

### 3.1.3 Connecting the Pipe at the Indoor Unit Side

Detach the caps and plugs from the pipes.

 <b>CAUTION!</b>
①. Be sure to apply the pipe against the port on the indoor unit correctly. If the centering is improper, the flare nut cannot be tightened smoothly. If the flare nut is forced to turn, the threads will be damaged.
②. Do not remove the flare nut until the connection pipe is to be connected so as to prevent dust and impurities from coming into the pipe system.

When connecting the pipe to the unit or removing it from the unit, please do use both the spanner and the torque wrench. (Figure 3-2-5)

When connecting, smear both inside and outside of the flare nut with refrigeration oil, screw it hand tight and then tighten it with the spanner.

Refer to Table 10 to check if the wrench has been tightened properly (too tight would mangle the nut and lead to leakage).

Examine the connection pipe to see if it leaks, then take the treatment of heat insulation, as shown in the Figure 3-2-5.

Use the medium-sized sponge to insulate the coupler of the gas pipe.

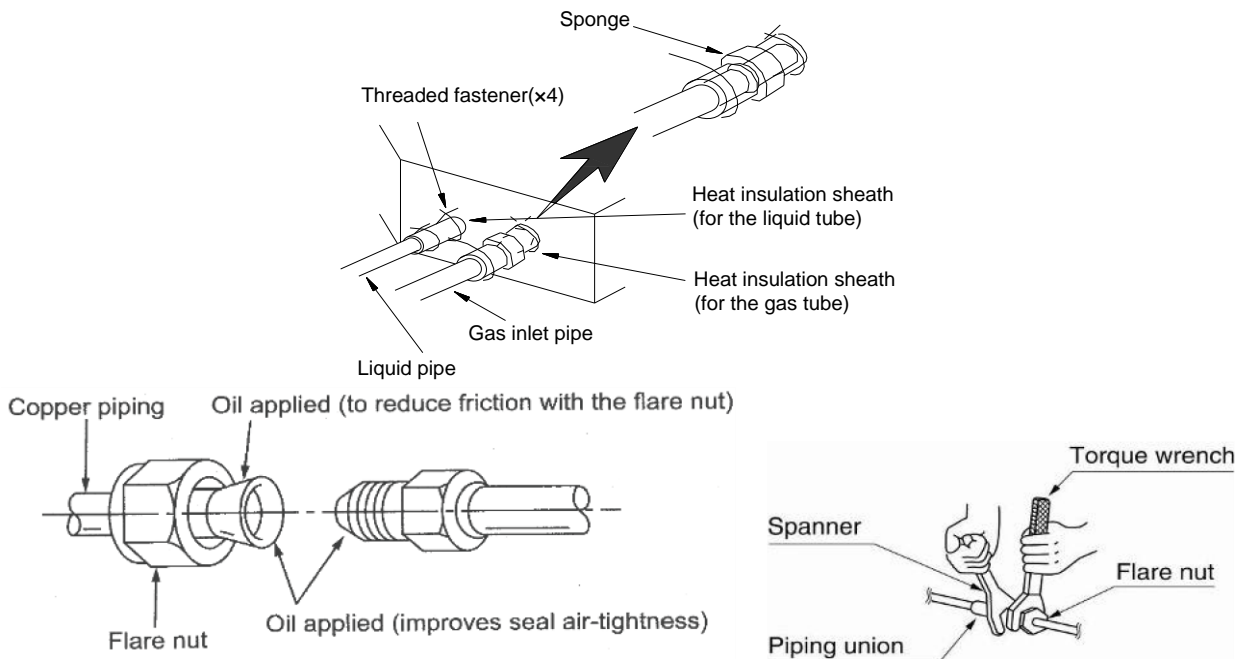

Figure 3-2-5

Table 3-2-2 Flare nut tightening torque

Pipe Diameter	Tightening Torque
1/4" (Inch)	15-30 (N·m)
3/8" (Inch)	35-40 (N·m)
1/2" (Inch)	45-50 (N·m)
5/8" (Inch)	60-65 (N·m)
3/4" (Inch)	70-75 (N·m)
7/8" (Inch)	80-85 (N·m)



**CAUTION!**

Be sure to connect the gas pipe after connecting the liquid pipe completely.

### 3.1.4 Connecting the Pipe at the Outdoor Side Unit

Tighten the flare nut of the connection pipe at the outdoor unit valve connector. The tightening method is the same as that as at the indoor side.

### 3.1.5 Checking the Pipe Connections for Gas Leaking

For both indoor and outdoor unit side, check the joints for gas leaking by the use of a gas leakage detector without fail when the pipes are connected.

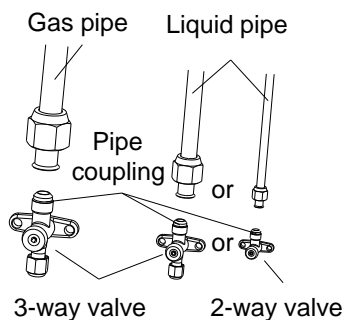

Figure 3-2-6

### 3.1.6 Heat Insulation on the Pipe Joints (Indoor Side Only)

Stick coupler heat insulation (large and small) to the place where connecting pipes.

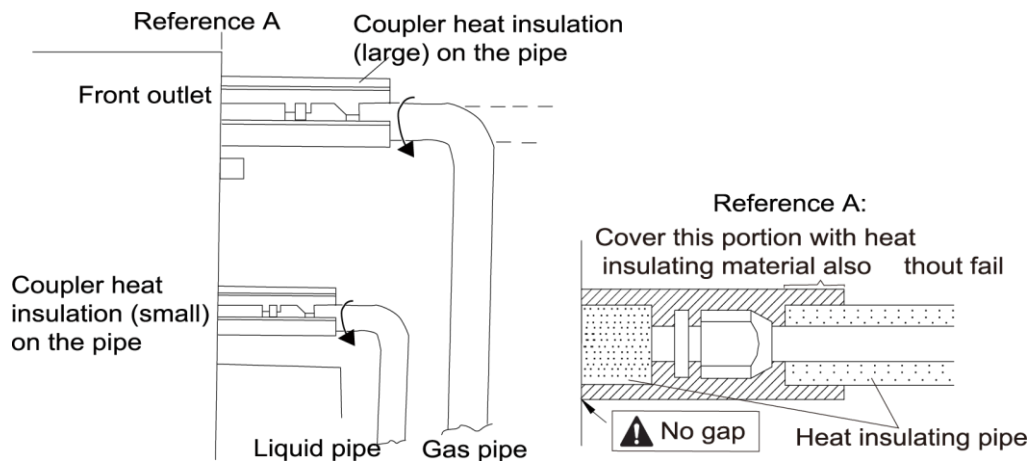

Figure 3-2-7

### 3.1.7 Vacuum and Gas Leakage Inspection



Do not purge the air with refrigerants but use a vacuum pump to vacuum the installation! There is no extra refrigerant in the outdoor unit for air purging!

#### 3.1.7.1 Vacuum

- (1) Remove the caps of the liquid valve, gas valve and also the service port.
- (2) Connect the hose at the low pressure side of the manifold valve assembly to the service port of the unit's gas valve, and meanwhile the gas and liquid valves should be kept closed in case of refrigerant leak.
- (3) Connect the hose used for evacuation to the vacuum pump.
- (4) Open the switch at the lower pressure side of the manifold valve assembly and start the vacuum pump. Meanwhile, the switch at the high pressure side of the manifold valve assembly should be kept closed, otherwise evacuation would fail.
- (5) The evacuation duration depends on the unit's capacity, generally, 30 minutes for the 24/36k units, 45 minutes for the 42/48/60 units. And verify if the pressure gauge at the low pressure side of the manifold valve assembly reads -1.0Mp (-75cmHg), if not, it indicates there is leak somewhere. Then, close the switch fully and then stop the vacuum pump.
- (6) Wait for some time to see if the system pressure can remain unchanged, 5 minutes for the 24/36k units, 10 minutes for the units more than 42k. During this time, the reading of the pressure gauge at the low pressure side can not be larger than 0.005Mp (0.38cmHg).
- (7) Slightly open the liquid valve and let some refrigerant go to the connection pipe to balance the pressure inside and outside of the connection pipe, so that air will not come into the connection pipe when removing the hose. Note that the gas and liquid valve can be opened fully only after the manifold valve assembly is removed.
- (8) Place back the caps of the liquid valve, gas valve and also the service port.

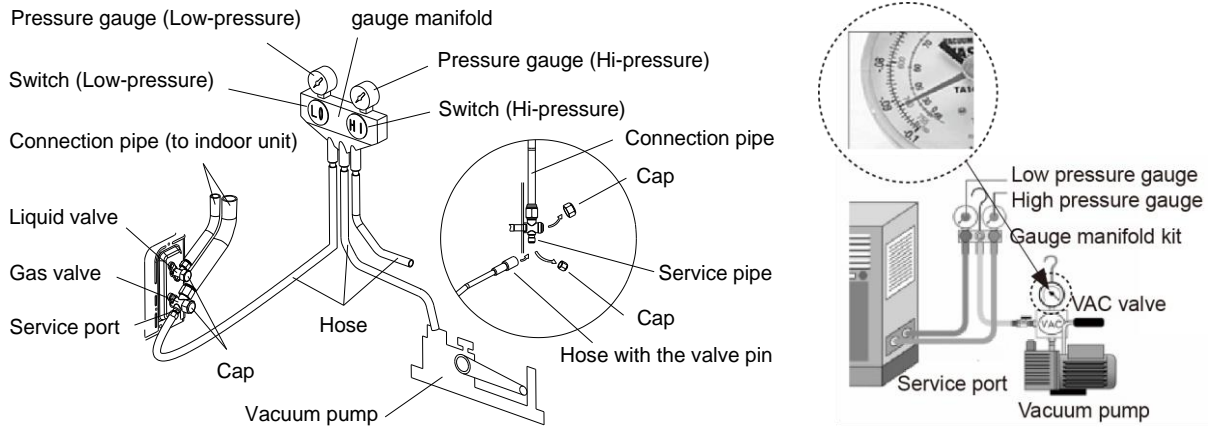

Figure 3-2-8

Note: For the large-sized unit, it has the service port for both the gas valve and the liquid valve. During evacuation, it is available to connect two hoses of the manifold valve assembly to two service ports to quicken the evacuating speed.

### 3.1.7.2 Additional Charge

Refrigerant suitable for a piping length of 7.5m is charged in the outdoor unit at the factory.

When the piping is longer than 9.5 m, additional charging is necessary.

For the additional amount, see Table 3-2-3.

Table 3-2-3

Model Item	Additional Refrigerant Amount for Extra Pipe
24-60k	60g/m

When the height difference between the indoor unit and outdoor unit is larger than 10 meters, an oil bend should be employed for every 6 meters.

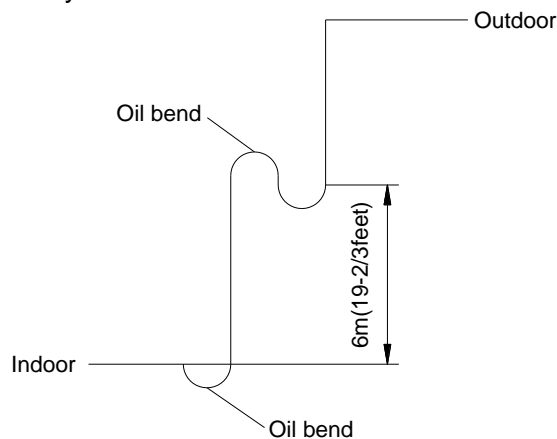

Figure 3-2-9

## 3.2 Specification of Connection Pipe

### 3.2.1 Duct Type

Table 3-2-4

Item Model		Size of Fitting Pipe (inch)		Max. Pipe Length (m)	Max. Height Difference between Indoor Unit and Outdoor Unit (m)	Drainage pipe(Outer Diameter x wall thickness) (mm)
		Liquid	Gas			
GFH24S3GI GFH24S3G1I	GUHD24NS3GO	3/8	5/8	50	15	Φ20×1.2
GFH36S3GI GFH36S31I	GUHD36NS3GO	3/8	5/8	50	15	Φ20×1.2
GFH42S3GI GFH42S3G1I	GUHD42NS3GO	3/8	5/8	50	30	Φ20×1.2
GFH48S3GI GFH48S3G1I	GUHD48NS3GO	3/8	5/8	50	30	Φ20×1.2
GFH60S3GI GFH60S3G1I	GUHD60NS3GO	3/8	3/4	50	30	Φ30×1.5

### 3.2.2 Cassette Type

Table 3-2-4

Item Model		Size of Fitting Pipe (inch)		Max. Pipe Length (m)	Max. Height Difference between Indoor Unit and Outdoor Unit (m)	Drainage pipe(Outer Diameter x wall thickness) (mm)
		Liquid	Gas			
GKH24S3GI	GUHD24NS3GO	3/8	5/8	50	15	Φ31.5×2.3
GKH36S3GI	GUHD36NS3GO				15	Φ31.5×2.3
GKH42S3GI	GUHD42NS3GO				30	Φ31.5×2.3
GKH48S3GI	GUHD48NS3GO				30	Φ31.5×2.3

The connection pipe should be insulated with proper water-proof insulating material.

The pipe wall thickness shall be 0.5-1.0 mm and the pipe wall shall be able to withstand the pressure of 6.0 MPa. The longer the connecting pipe, the lower the cooling and heating effect performs.

## 4 ELECTRIC WIRING WORK

### 4.1 Wiring Precautions

 WARNING
①. Before obtaining access to terminals, all supply circuits must be disconnected.
②. The rated voltage of the unit is as shown as Table 1-4-1 and Table 1-4-2
③. Before turning on, verify that the voltage is within the 198~264V range (for single phrase unit) .
④. Always use a special branch circuit and install a special receptacle to supply power to the air conditioner.
⑤. Use a special branch circuit breaker and receptacle matched to the capacity of the air conditioner.
⑥. The special branch circuit breaker is installed in the permanent wiring. Always use a circuit that can trip all the poles of the wiring and has an isolation distance of at least 3 mm between the contacts of each pole.
⑦. Perform wiring work in accordance with standards so that the air conditioner can be operated safely and positively.
⑧. Install a leakage special branch circuit breaker in accordance with the related laws and regulations and electric company standards.



- ①. The power source capacity must be the sum of the air conditioner current and the current of other electrical appliances. When the current contracted capacity is insufficient, change the contracted capacity.
- ②. When the voltage is low and the air conditioner is difficult to start, contact the power company to raise the voltage.

## 4.2 Electrical Wiring

(1) For solid core wiring (Figure 3-2-10)

- 1) Cut the wire end with a wire cutter or wire-cutting pliers, then strip the insulation about 25 mm (15/16").
- 2) Using a screwdriver, remove the terminal screw(s) on the terminal board.
- 3) Using pliers, bend the solid wire to form a loop suitable for the terminal screw.
- 4) Shape the loop wire properly, place it on the terminal board and tighten securely with the terminal screw using a screwdriver.

(2) For strand wiring (Figure 3-2-10)

- 1) Cut the wire end with a wire cutter or wire-cutting pliers, then strip the insulation about 10 mm (3/8")
- 2) Using a screwdriver, remove the terminal screw (s) on the terminal board.
- 3) Using a round terminal fastener or pliers, securely clamp a round terminal to each stripped wire end.
- 4) Position the round terminal wire, and replace and tighten the terminal screw with a screwdriver.( Figure 3-2-11)

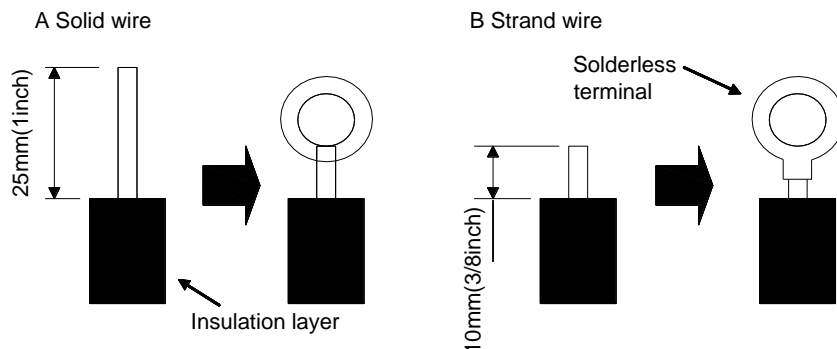

Figure 3-2-10

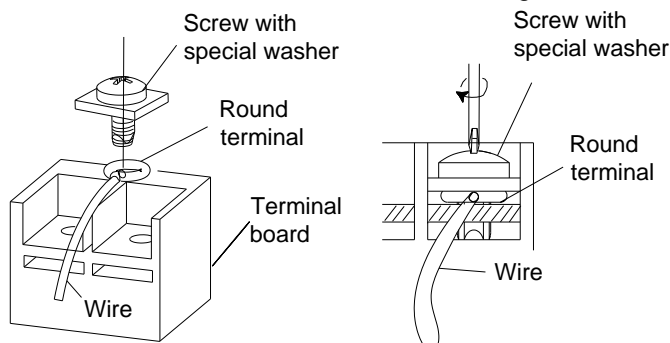

Figure 3-2-11

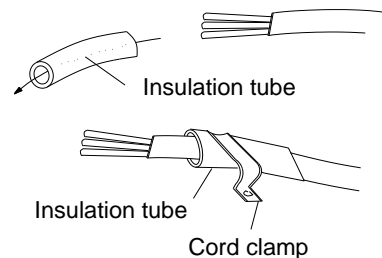

Figure 3-2-12

(3) How to fix connection cord and power cord by cord clamp

After passing the connection cord and power cord through the insulation tube, fasten it with the cord clamp. (Figure 3-2-12)



- ①. Before starting work, check that power is not being supplied to the indoor unit and outdoor unit.
- ②. Match the terminal block numbers and connection cord colors with those of the indoor unit side.
- ③. Erroneous wiring may cause burning of the electric parts.
- ④. Connect the connection cords firmly to the terminal block. Imperfect installation may cause a fire.
- ⑤. Always fasten the outside covering of the connection cord with cord clamps. (If the insulator is not clamped, electric leakage may occur.)
- ⑥. Always connect the ground wire.

(4) Electric wiring between the indoor and outdoor units

◆ Single-phase units

Separate Power Supply for indoor unit and outdoor unit:

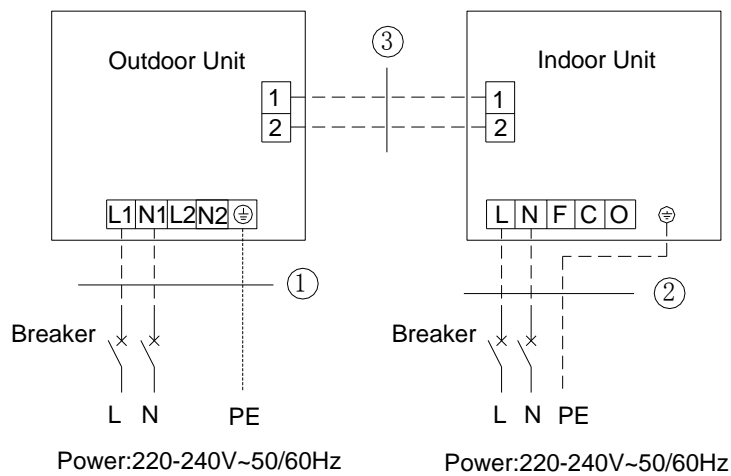

24~60k

GUHD24NS3GO+GFH24S3GI/GFH24S3G1I/GKH24S3GI
①. Power cord 3×2.5mm <sup>2</sup> (H07RN-F)
②. Power cord 3×1.0mm <sup>2</sup> (H05RN-F)
③. Communication Cords 2×0.75mm <sup>2</sup> (H05RN-F)

GUHD36NS3GO+GFH36S3GI/GFH36S3G1I/GKH36S3GI
GUHD42NS3GO+GFH42S3GI/GFH42S3G1I/GKH42S3GI
①. Power cord 3×4.0mm <sup>2</sup> (H07RN-F)
②. Power cord 3×1.0mm <sup>2</sup> (H05RN-F)
③. Communication Cords 2×0.75mm <sup>2</sup> (H05RN-F)

GUHD48NS3GO+GFH48S3GI/GFH48S3G1I/GKH48S3GI
GUHD60NS3GO+GFH60S3GI/GFH60S3G1I
①. Power cord 3×6.0mm <sup>2</sup> (H07RN-F)
②. Power cord 3×1.0mm <sup>2</sup> (H05RN-F)
③. CommunicationCords 2×0.75mm <sup>2</sup> (H05RN-F)

- ◆ The Power supply for indoor units from outdoor unit.

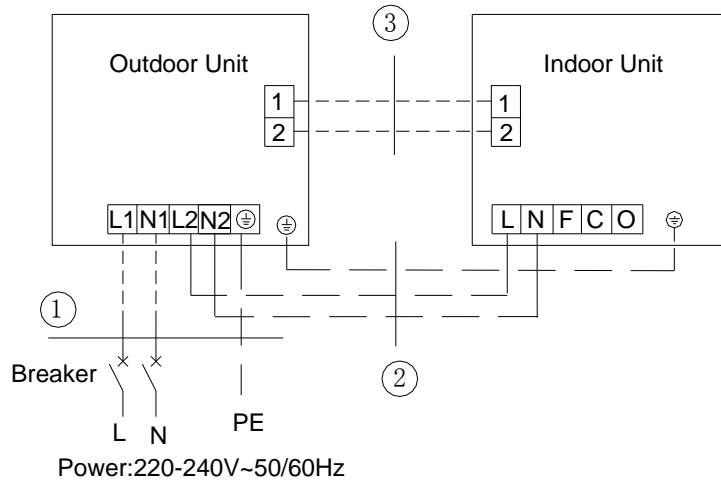

24~60k

Figure 3-2-13

(5) Electric wiring of indoor unit side

Remove the electric box cover from the electric box sub-assy and then connect the wire.

- ◆ Duct Type Unit:

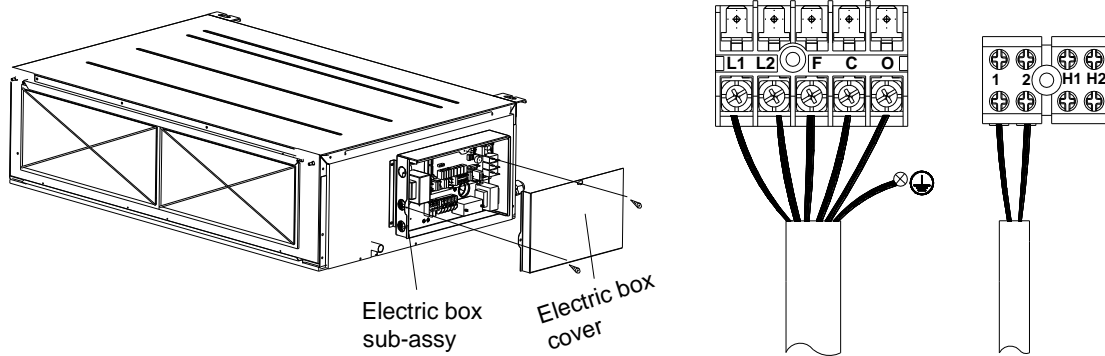

Figure 3-2-14

The F, C, O connect to the COMMOM, CLOSE and OPEN terminal of the fresh air valve respectively.

- ◆ Cassette Type Unit:

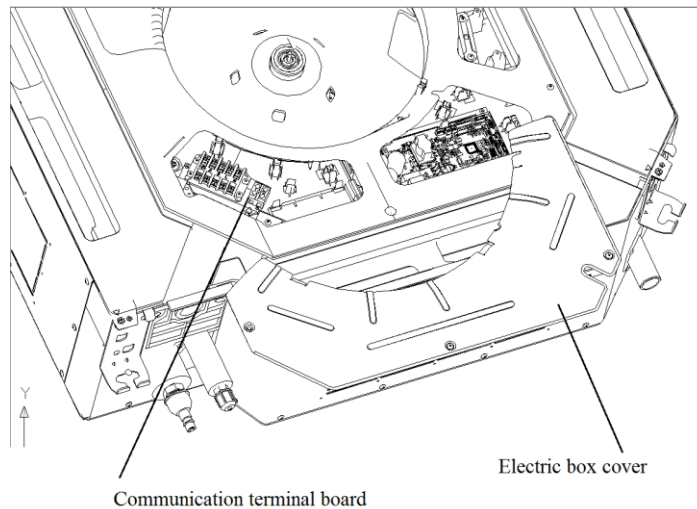

Figure 3-2-15



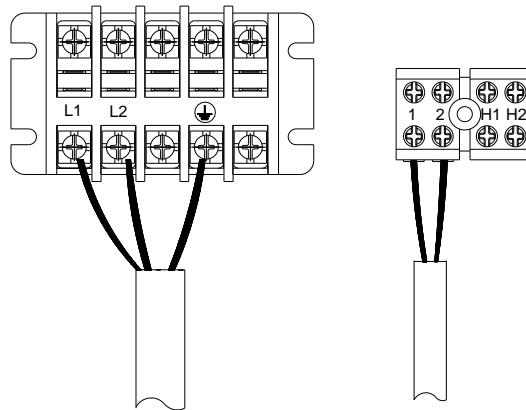



Figure 3-2-16

 <b>CAUTION!</b>	
①	The power cord and the wire of the fresh air valve are high-voltage, while the communication cord and connection wire of the wired controller are low-voltage. They should run separately against electromagnetic interference.
②	The high-voltage and low-voltage lines should pass through the rubber rings at different electric box covers.
③	Do not bundle the connection wire of the wired controller and the communication cord together, or arrange them in parallel, otherwise improper operation would occur.
④	The high-voltage and low-voltage lines should be fixed separately and securely, with internal big clamps for the former and small clamps for the latter.
⑤	Tighten the indoor/outdoor connection cord and power cord respectively on the terminal boards with screws. Faulty connection may cause a fire.
⑥	If the indoor unit connection cord (to the outdoor unit) and power supply are wired incorrectly, the air conditioner may be damaged.
⑦	Connect the indoor unit connection cord properly based on the corresponding marks as shown in Figure 3-2-9.
⑧	Ground both the indoor and outdoor units by attaching a ground wire.
⑨	Unit shall be grounded in compliance with the applicable local and national codes.

(6) Electric wiring of outdoor unit side

**Note:** When connecting the power supply cord, make sure that the phase of the power supply matches with the exact terminal board. If not, the compressor will rotate reversely and run improperly.

Remove the big handle 24k /front board (36-60k) of the outdoor unit and insert the end of the communication cord and the power cable into the terminal board.

◆ Single phase:

- 1) Separate Power Supply for indoor unit and outdoor unit:

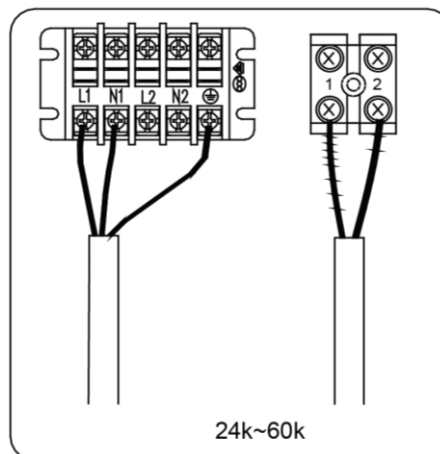

Figure 3-2-17

2) The Power supply for indoor units from outdoor unit.

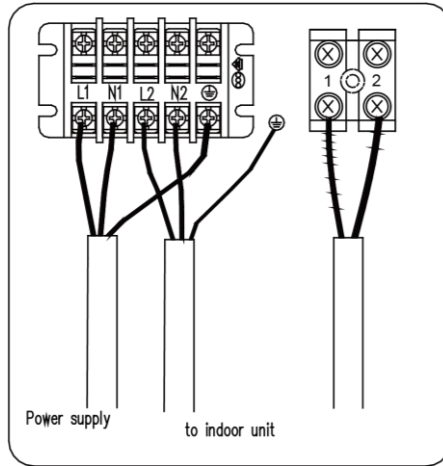

Figure 3-2-18

Power lines should go along the right side plate. Communication lines between indoor and outdoor units also should go along the right side plate and keep away from power lines.

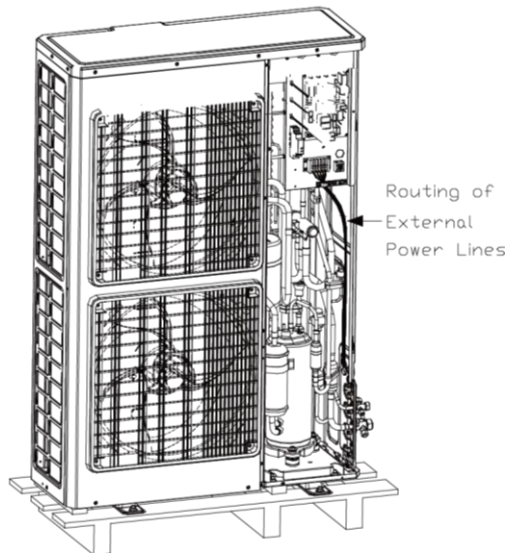

Figure 3-2-19

# MAINTENANCE

# MAINTENANCE

## 1 TROUBLE TABLE

### 1.1 Main Control Malfunction

Table 1 Fault Display on Indoor Wired Controller

No.	Error code	Malfunction name	Origin of malfunction signal	Control description
1	E1	High pressure protection	High pressure switch	When outdoor unit detects the high pressure switch is cut off for 3s successively, high pressure protection will occur. All the loads (except the 4-way valve in heating mode) will be switched off. In this case, all the buttons and remote control signals except ON/OFF button will be disabled and cannot be recovered automatically. Switch off the unit or re-energize the unit after cutting off power to eliminate this protection.
2	E2	Freeze protection	Indoor evaporator temperature sensor	If detecting that the evaporator temperature is lower than protective temp. Value after the unit has been running for a period of time under cooling or dry mode, the unit will report this fault, in which case the compressor and outdoor fan motor will be stopped. The unit will not run until evaporator temperature is higher than the protective temp. value and the compressor is stopped for 3min.
3	E3	Low pressure protection	Low pressure switch	If it is detected within 30s successively that the low-pressure switch is cut off under ON or standby state, the unit will report low pressure protection. If the fault occurs successively 3 times within 30min, the unit cannot be recovered automatically.
		Refrigerant lacking protection		If the unit reports system refrigerant lacking within 10min after turning on the unit, the unit will stop operation. If the fault occurs successively 3 times, the unit cannot be recovered automatically.
		Refrigerant recycling mode		If enter refrigerant recycling mode through special operation, E3 will be displayed. After exiting refrigerant recycling mode, the code will disappear.
4	E4	Compressor high discharge temperature protection	Compressor discharge temperature is high	If outdoor unit detects that the discharge temperature is higher than protective temp. Value, the unit will report high discharge temperature protection. If the protection occurs over 6 times, the unit cannot be recovered automatically. Switch off the unit or re-energize the unit after cutting off power to eliminate this protection.
6	E6	Communication malfunction	Communication between indoor and outdoor mainboard	If the outdoor unit does not receive data from indoor unit, communication malfunction will be reported. If there is communication abnormality between display board and indoor unit, communication malfunction will be reported too.
8	E8	Malfunction of indoor fan motor	Indoor fan motor	If the indoor unit does not receive signal from indoor fan motor for 30s successively when the fan motor is operating, indoor fan motor malfunction will be reported. In this case, the unit can automatically resume operation after stopping. If the malfunction occurs 6 times within one hour, the unit cannot be recovered automatically. Switch off the unit or re-energize the unit after cutting off power to eliminate this malfunction.
9	E9	Full water protection	Water level switch	If cut-off of water level switch is detected for 8s successively once energized, the system will enter full water protection. In this case, switch off the unit and then switch it on to eliminate this malfunction.
10	F0	Malfunction of indoor ambient temperature sensor at air return port	Indoor ambient temperature sensor	If the indoor ambient temperature sensor is detected of open circuit or short circuit for 5s successively, indoor ambient temperature sensor malfunction will be reported. The unit can automatically resume operation after the malfunction disappears. If indoor ambient temperature sensor malfunction occurs in fan mode, only the error code is displayed and the indoor unit can work normally.

No.	Error code	Malfunction name	Origin of malfunction signal	Control description
11	F1	Malfunction of evaporator temperature sensor	Evaporator temperature sensor	If the indoor evaporator temperature sensor is detected of open circuit or short circuit for 5s successively, evaporator temperature sensor malfunction will be reported. The unit can automatically resume operation after the malfunction disappears. If evaporator temperature sensor malfunction occurs in fan mode, only the error code is displayed and the indoor unit can work normally.
12	F2	Malfunction of condenser temperature sensor	Condenser temperature sensor	If the outdoor condenser temperature sensor is detected of open circuit or short circuit for 5s successively, condenser temperature sensor malfunction will be reported. The unit can automatically resume operation after the malfunction disappears. If condenser temperature sensor malfunction occurs in fan mode, only the error code is displayed and the indoor unit can work normally.
13	F3	Malfunction of outdoor ambient temperature sensor	Outdoor ambient temperature sensor	If the outdoor ambient temperature sensor is detected of open circuit or short circuit for 5s successively, outdoor ambient temperature sensor malfunction will be reported. The unit can automatically resume operation after the malfunction disappears. If outdoor ambient temperature sensor malfunction occurs in fan mode, only the error code is displayed and the indoor unit can work normally.
14	F4	Malfunction of discharge temperature sensor	Discharge temperature sensor	If the outdoor discharge temperature sensor is detected of open circuit or short circuit for 5s successively after the compressor has been operating for 3min, outdoor discharge temperature sensor malfunction will be reported. The unit can automatically resume operation after the malfunction disappears.
15	F5	Malfunction wired controller temperature sensor	Wired controller	If the wired controller detects open circuit or short circuit of its temperature sensor for 5s successively, wired controller temperature sensor malfunction will be reported.
18	ee	Malfunction of outdoor drive memory chip	Outdoor drive board	If the memory chip of outdoor drive board is broken, the unit cannot be started. The unit cannot be recovered automatically. If the malfunction cannot be eliminated after switching off the unit and then energizing the unit for several times, please replace the outdoor drive board.
20	H3	Compressor overload protection	Compressor overload switch	If it is detected within 3s successively that the overload switch is cut off under ON or standby state, the unit will report overload protection. If the fault occurs successively 3 times, the unit cannot be recovered automatically. Switch off the unit or re-energize the unit after cutting off power to eliminate this protection.
21	H4	Overload protection	Evaporator temperature, condenser temperature	If outdoor unit detects that the tube temperature is higher than protective temp. Value, the unit will report overload protection. The unit will not restart operation until tube temperature is lower than the protective temp. Value and the compressor is stopped for 3min. If the protection occurs over 6 times, the unit cannot be recovered automatically. Switch off the unit or re-energize the unit after cutting off power to eliminate this protection.
23	H6	Malfunction of outdoor fan motor	Outdoor fan motor	If the outdoor unit does not receive signal from outdoor fan motor for 30s successively when the fan motor is operating, outdoor fan motor malfunction will be reported. In this case, the unit can automatically resume operation after stopping. If the malfunction occurs 6 times within one hour, the unit cannot be recovered automatically. Switch off the unit or re-energize the unit after cutting off power to eliminate this malfunction.

No.	Error code	Malfunction name	Origin of malfunction signal	Control description
32	U7	Direction changing malfunction of 4-way valve	4-way valve	After the compressor starts operation in heating mode, if the outdoor unit detects the difference between evaporator temperature and indoor ambient temperature is lower than the protective value for 10min successively, direction changing malfunction of 4-way valve will be reported and the outdoor unit will stop operation. The unit can automatically resume operation in the first two malfunctions. If the malfunction occurs 3 times, the unit cannot be recovered automatically. Switch off the unit or re-energize the unit after cutting off power to eliminate this malfunction.
35	P6	Communication malfunction between main control and drive	Communication between main control board and drive board	If the outdoor main control board does not receive data from drive board, communication malfunction between main control and drive will be reported. This malfunction can be eliminated automatically.
47	EE	Malfunction of outdoor main control memory chip	Outdoor main control board	If the memory chip of outdoor main control board is broken, the unit cannot be started. The unit cannot be recovered automatically. If the malfunction cannot be eliminated after switching off the unit and then energizing the unit for several times, please replace the outdoor main control board.
48	oE	/	/	Malfunctions of outdoor unit, please refer to status of error indicator in outdoor unit

## 1.2 Description of Drive Malfunction

Main board dual 8 numeral tube Display Codes for Outdoor Unit of 24~60k

Malfunction Item	Indoor Unit Display	Outdoor unit display of dual 8 numeral tube
DC busbar over-voltage protection	PH	PH
IPM or PFC over-temperature protection	P8	P8
Current sense circuit error	Pc	Pc
IPM or PFC temperature sensor error	P7	P7
Compressor current protection	P5	P5
DC busbar under-voltage protection	PL	PL
Compressor startup failure	Lc	Lc
Drive module reset	P0	P0
Compressor motor desynchronizing	H7	H7
Phase loss	Ld	Ld
Drive-to-main-control communication error	P6	P6
IPM protection	H5	H5
Compressor overload protection	H3	H3
AC current protection (input side)	PA	PA
Charging circuit error	PU	PU
PFC protection	HC	HC
DC fan error	H6	H6
Input AC voltage abnormality	PP	PP
Driving board memory chip error	ee	ee

# 2 FLOW CHART OF TROUBLESHOOTING

## 2.1 Troubleshooting Flow Chart of Main Control Malfunction

### ◆ E1 High Pressure Protection

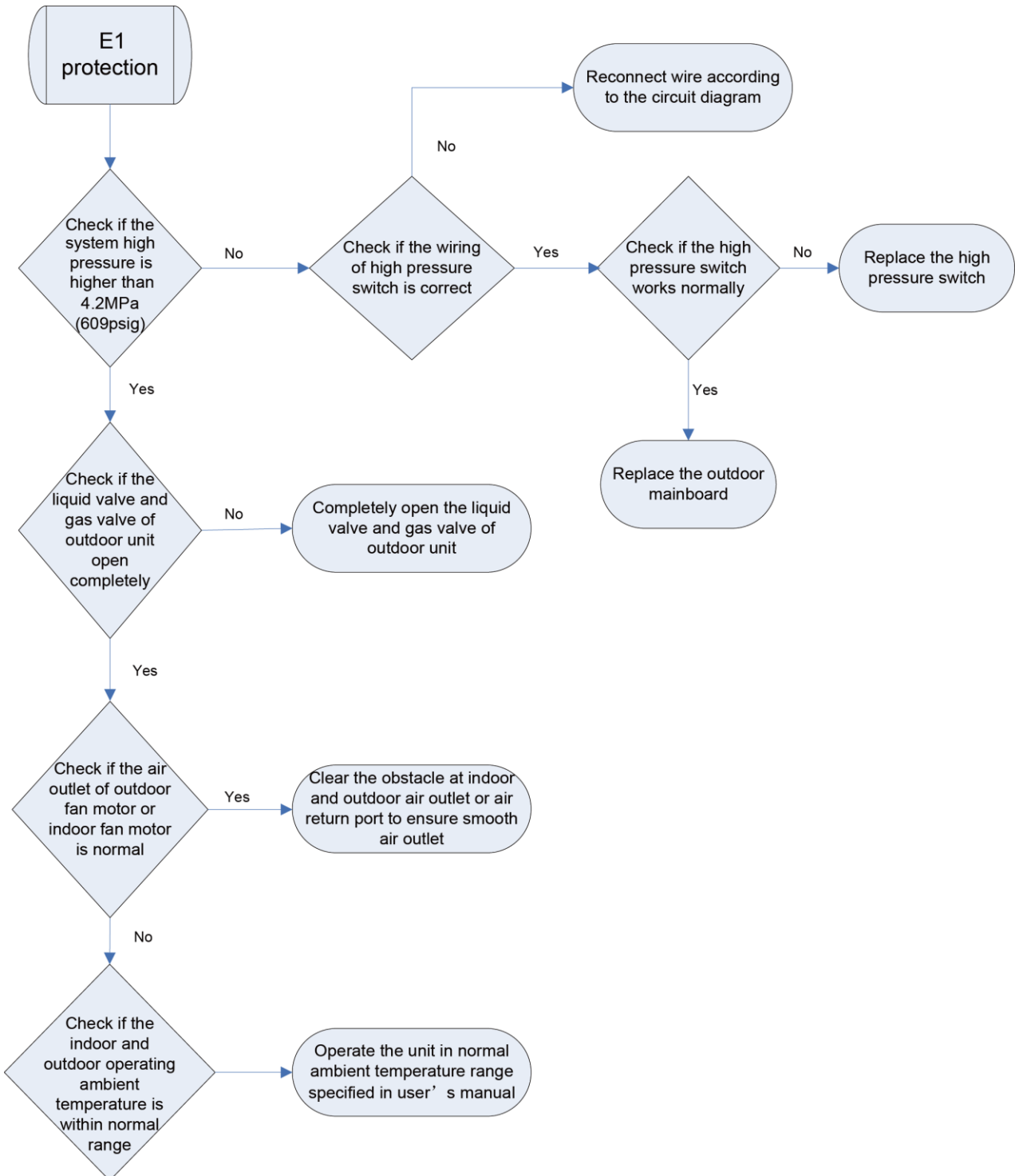

### ◆ E2 Freeze Protection

Freeze protection is normal protection but not abnormal malfunction. If freeze protection occurs frequently during operation, please check if the indoor filter is with filth blockage or if the indoor air outlet is abnormal. The user is required to clean the filter, check the air outlet and air return pipe periodically to ensure smooth air return and air outlet.

◆ E3 stands for three statuses:

- (1) Low pressure protection;
- (2) Refrigerant lacking protection;
- (3) Refrigerant recycling mode;

1) If enter refrigerant recycling mode through special operation, the displayed E3 is not an error code. It will be eliminated when exiting refrigerant recycling mode.

2) If you do not want to have refrigerant lacking protection, you can enter the debugging mode through wired controller and then cancel the refrigerant lacking protection mode.

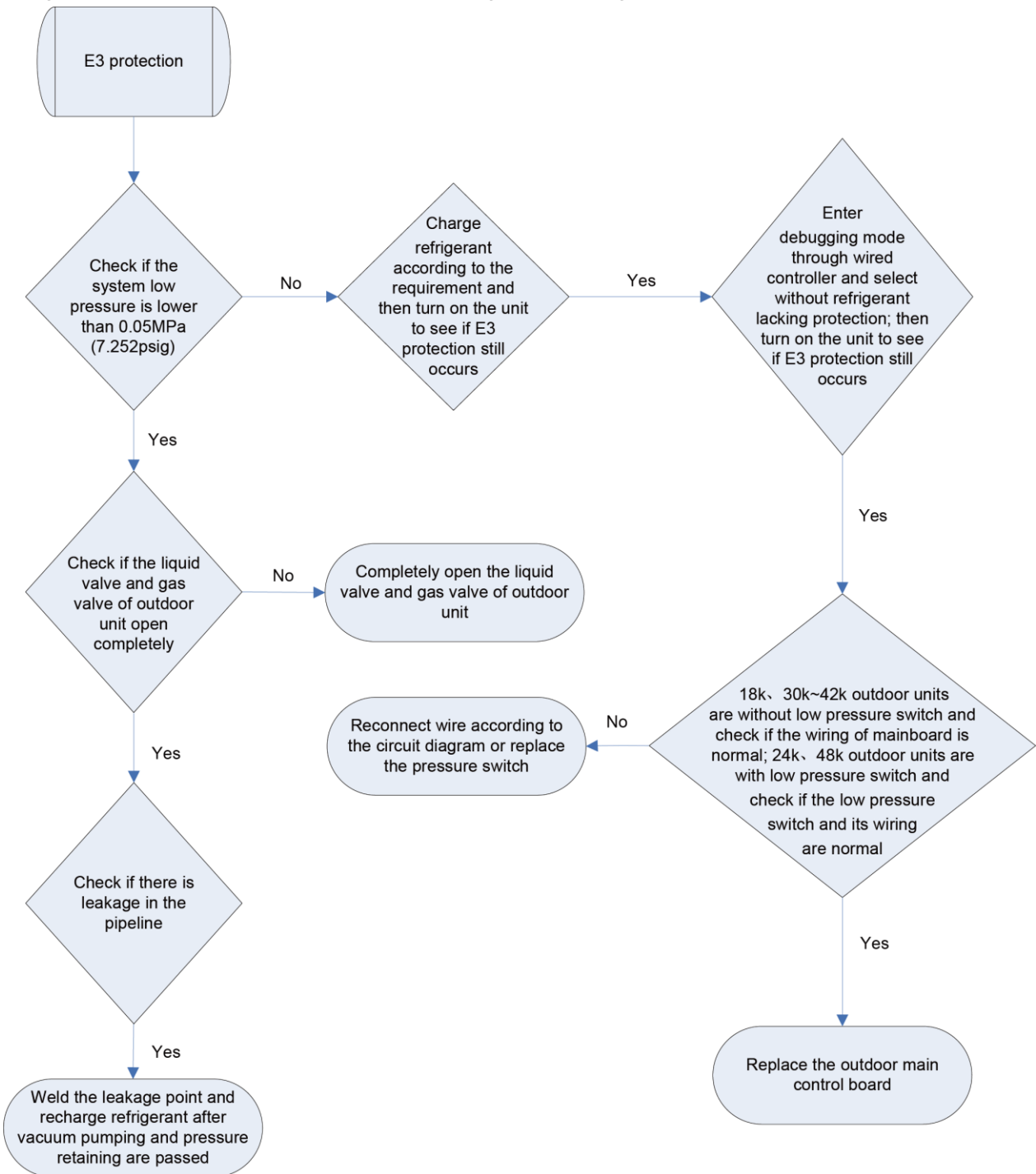



◆ E4 Discharge Protection

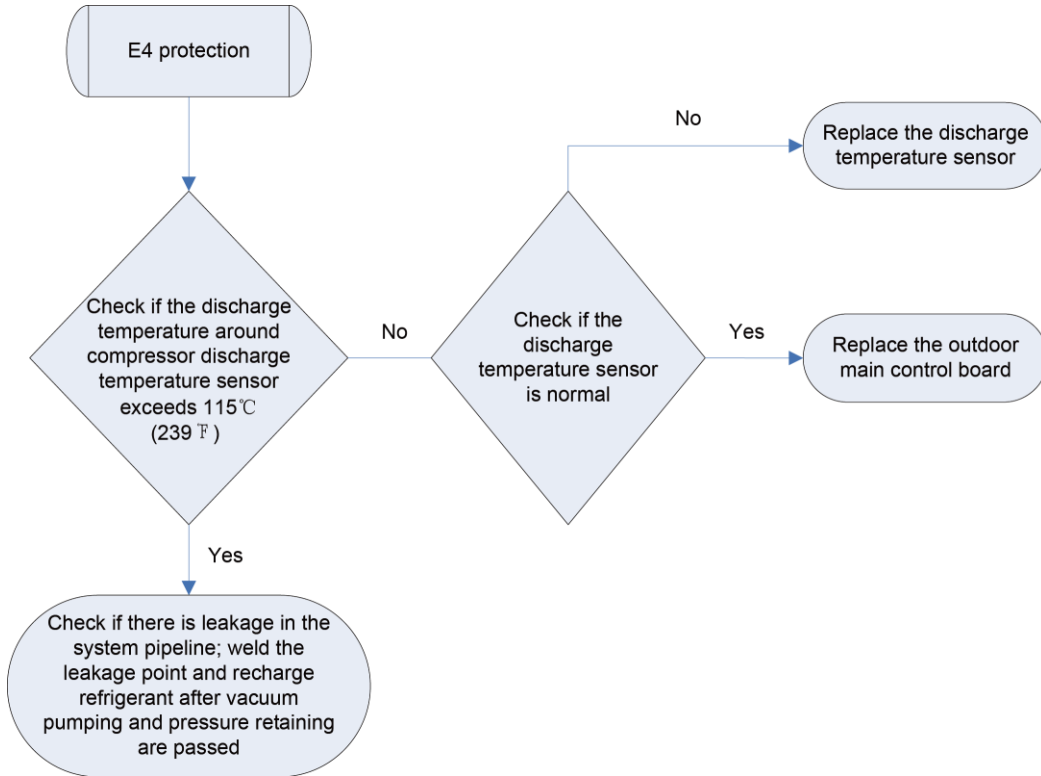

◆ E6 Communication Malfunction

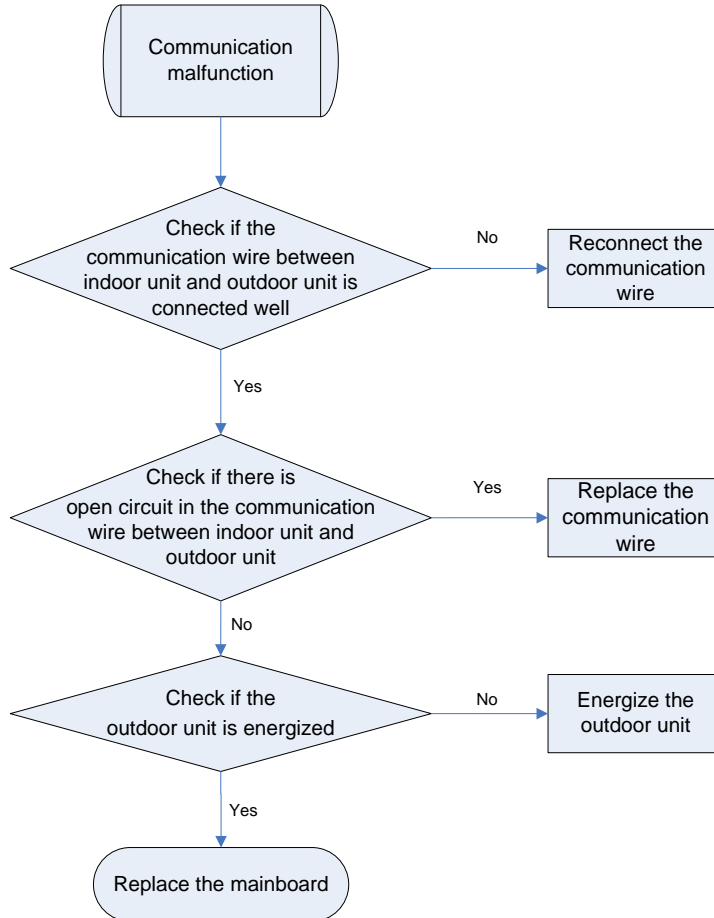

◆ E9 Full Water Protection

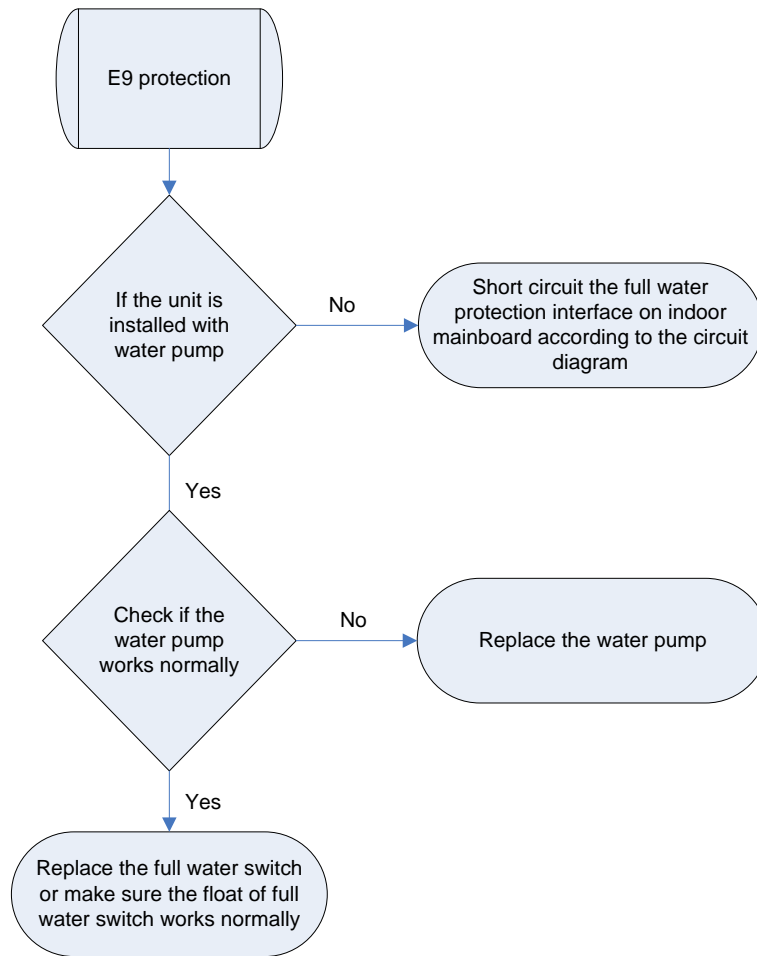

◆ F0 Malfunction of Indoor Ambient Temperature Sensor

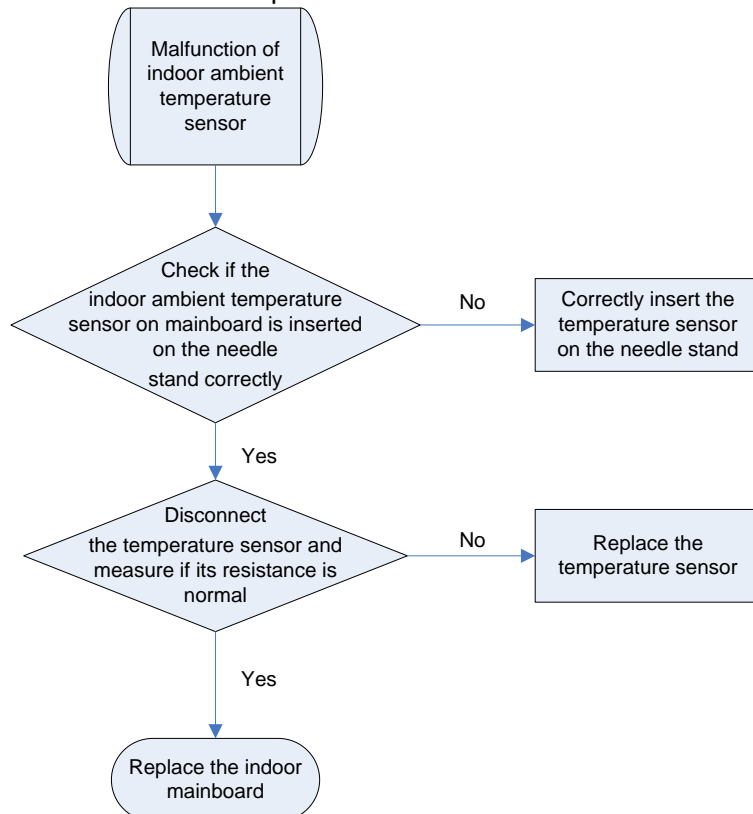

◆ F1 Malfunction of Evaporator Temperature Sensor

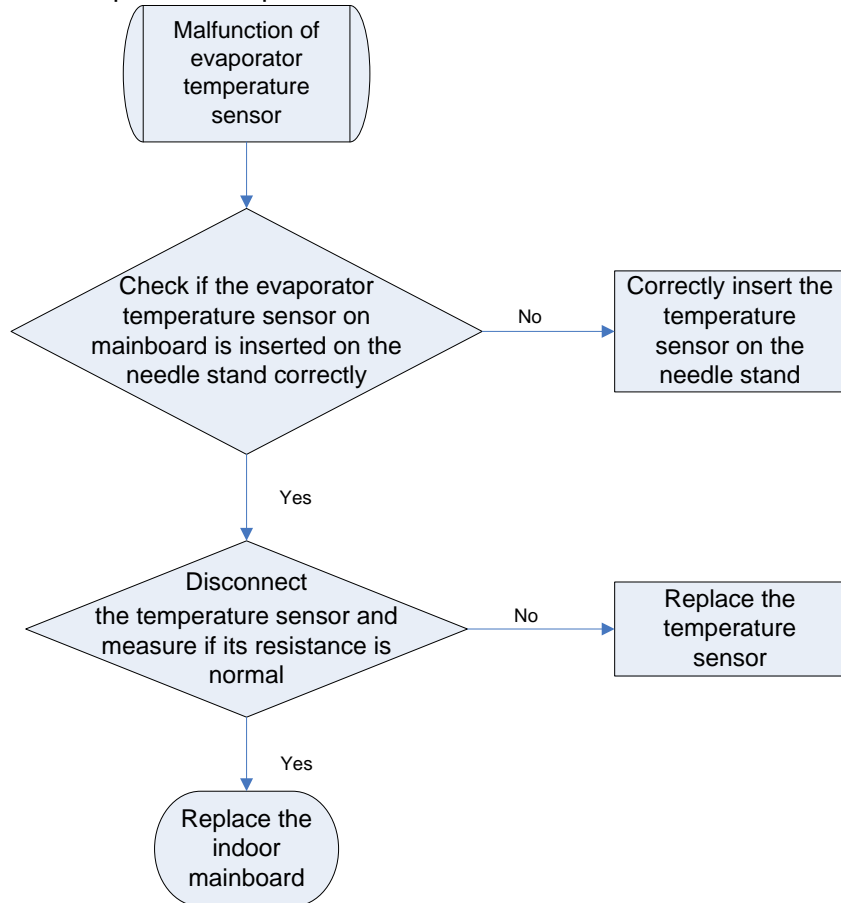

◆ F2 Malfunction of Condenser Temperature Sensor

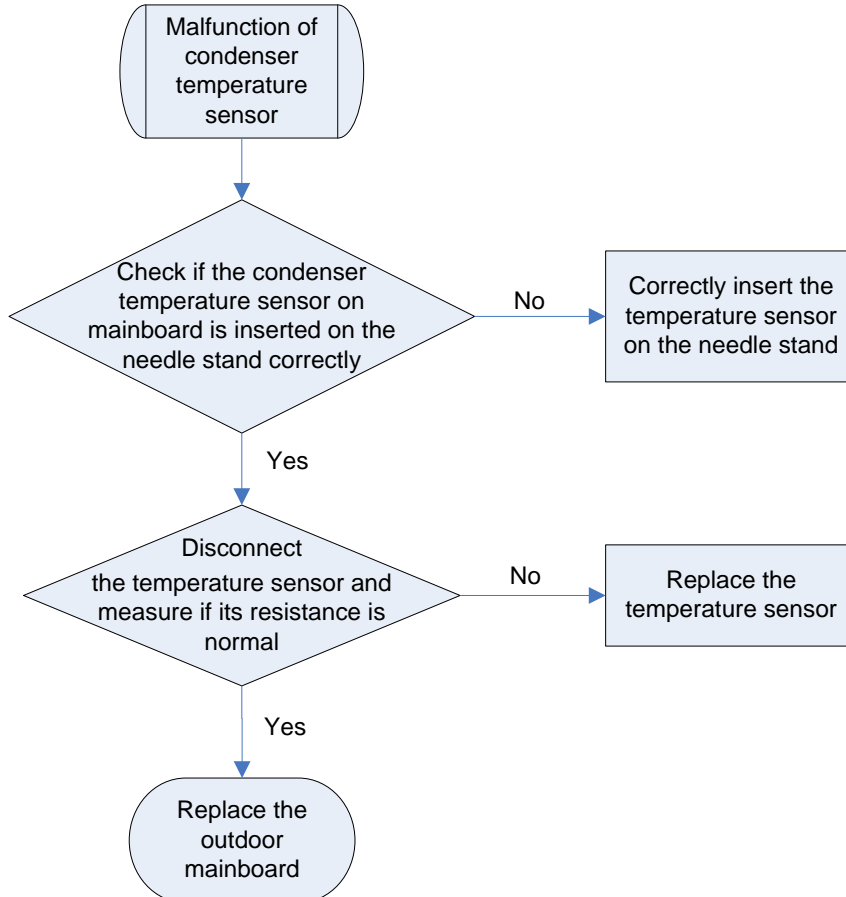

◆ F3 Malfunction of Outdoor Ambient Temperature Sensor

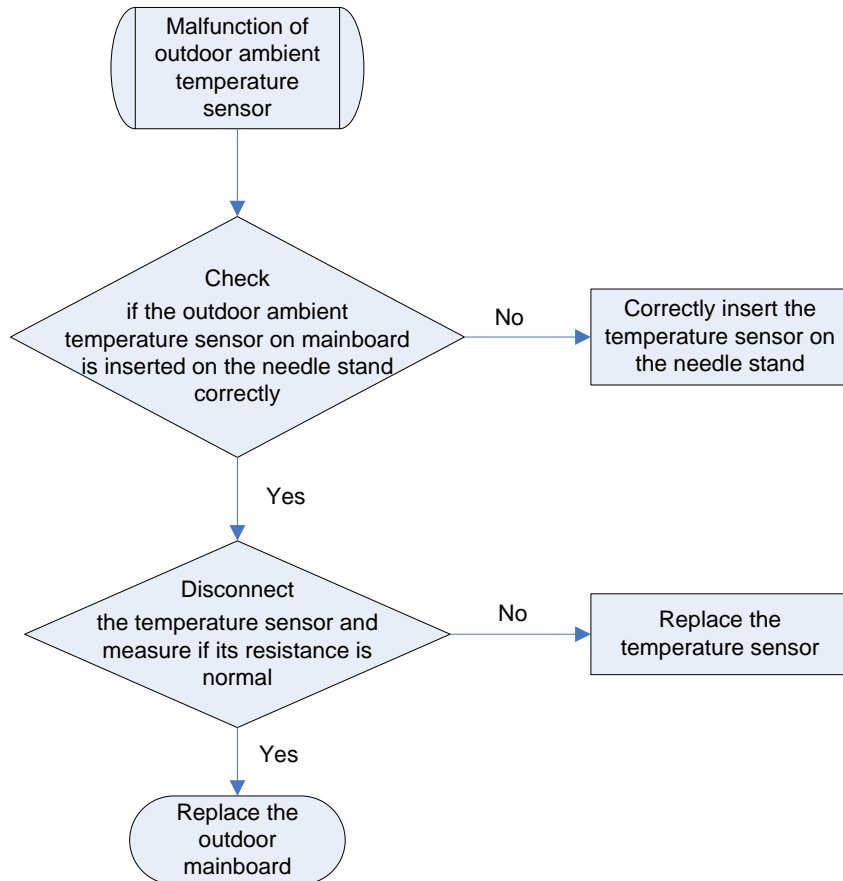

◆ F4 Malfunction of Discharge Temperature Sensor

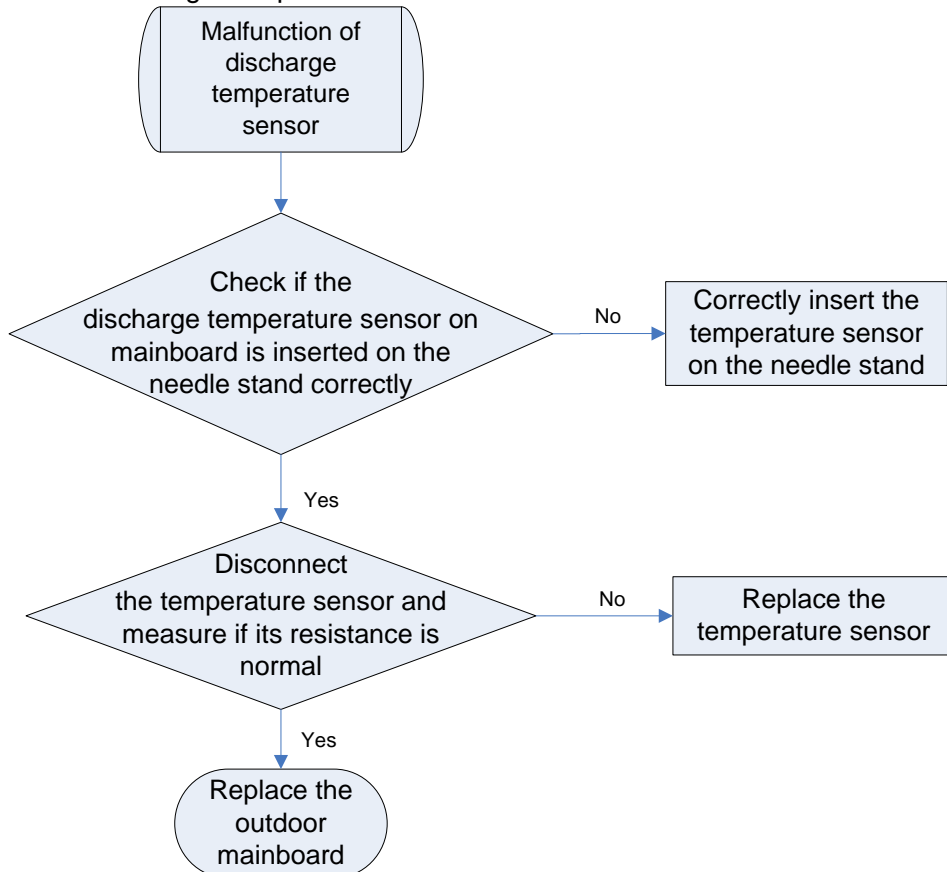

◆ F5 Malfunction of Wired Controller Temperature Sensor

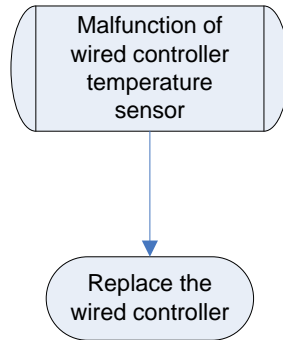

◆ H6 Malfunction of Outdoor Fan Motor

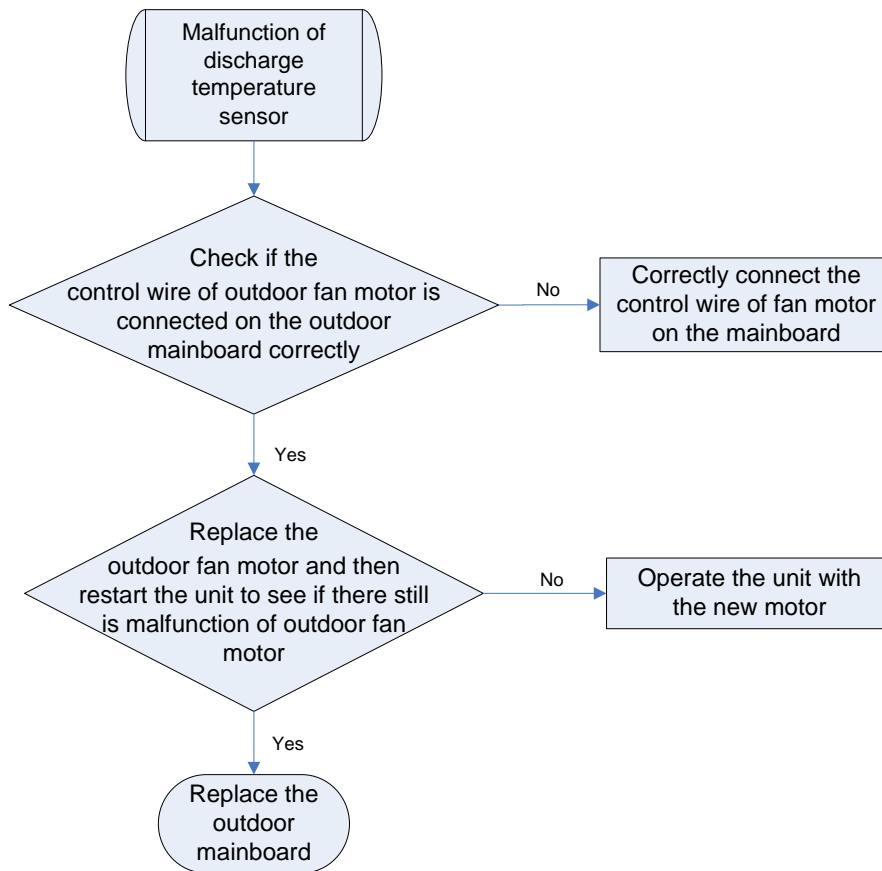

◆ E8 Malfunction of Indoor Fan Motor

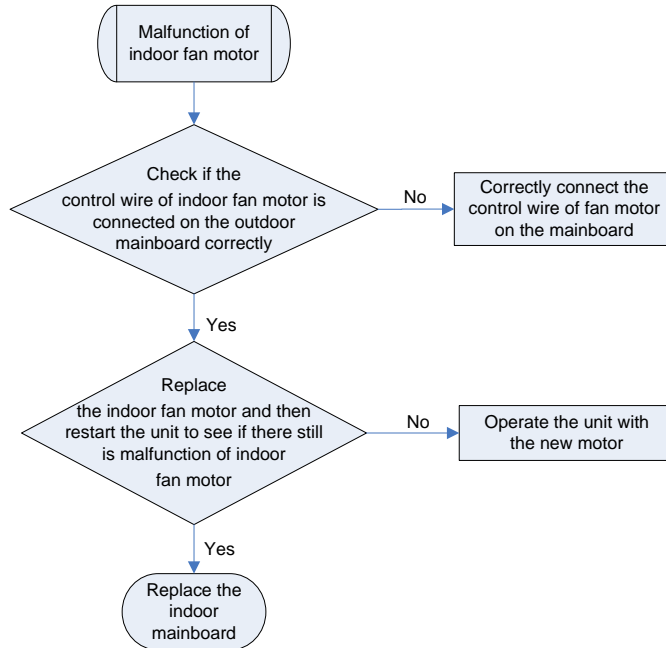

## 2.2 Troubleshooting Flow Chart of Drive Malfunction

**Note:** For Outdoor Unit Drive (Inverter) by Single-phase Motor

P0 Drive module reset

- ◆ P7 IPM or PFC temperature sensor error
- ◆ PA AC current protection (input side)
- ◆ PC Current sense circuit error
- ◆ HC PFC protection (42\48k\60k only)

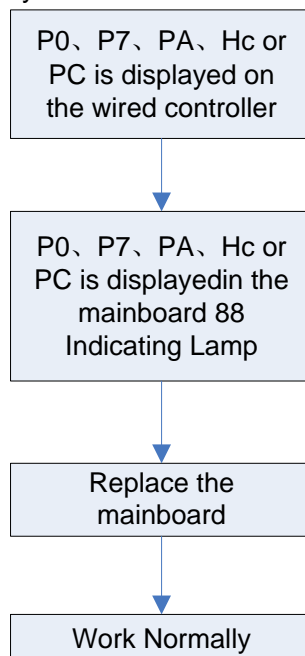

◆ P8 IPM or PFC over-temperature protection

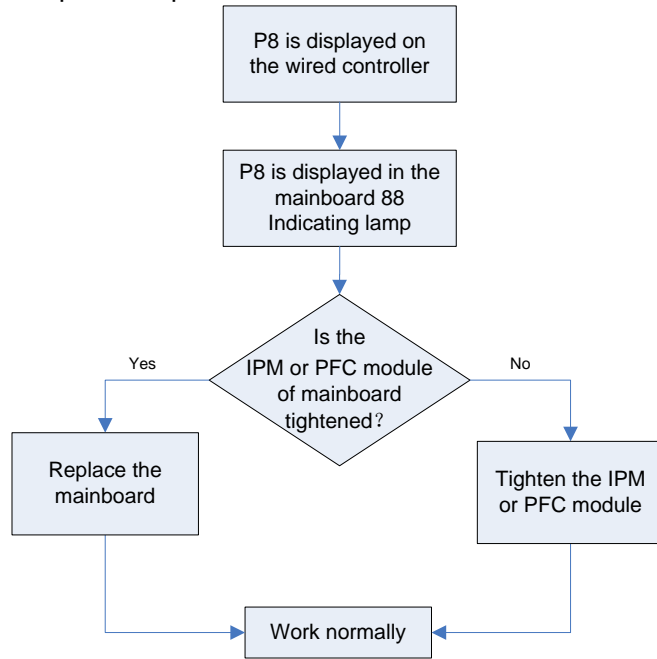

◆ PH DC busbar over-voltage protection

◆ PL DC busbar under-voltage protection

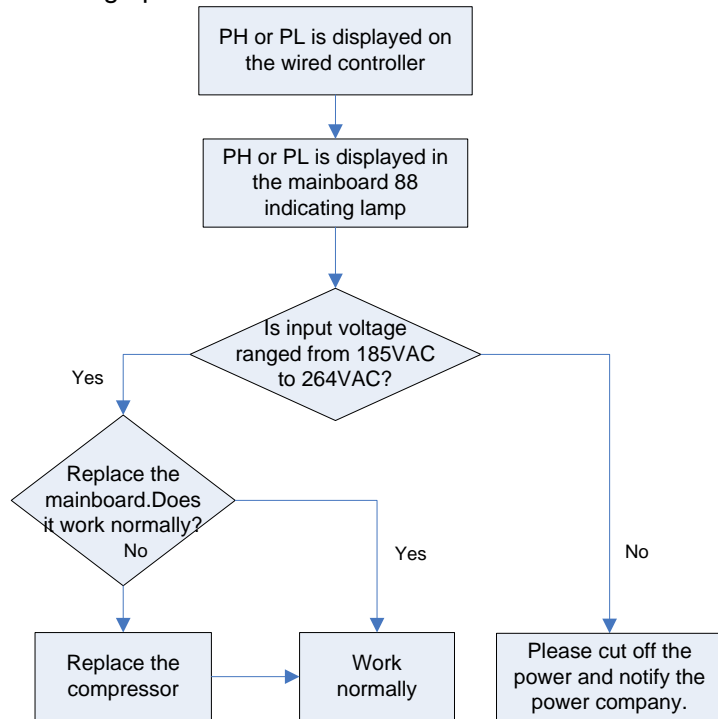

- ◆ P6 Drive-to-main-control communication error
- ◆ Lc Compressor Startup Failure

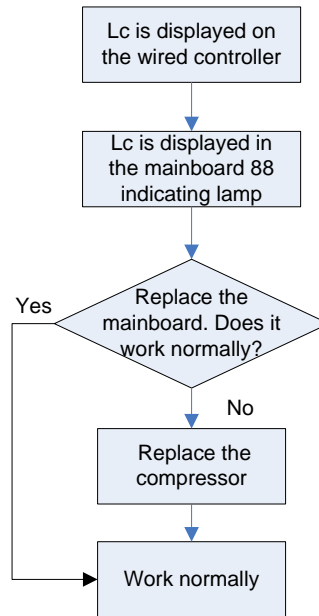

- ◆ P5 Compressor current protection
- ◆ H7 Compressor motor desynchronizing
- ◆ H5 IPM protection
- ◆ Ld Phase loss

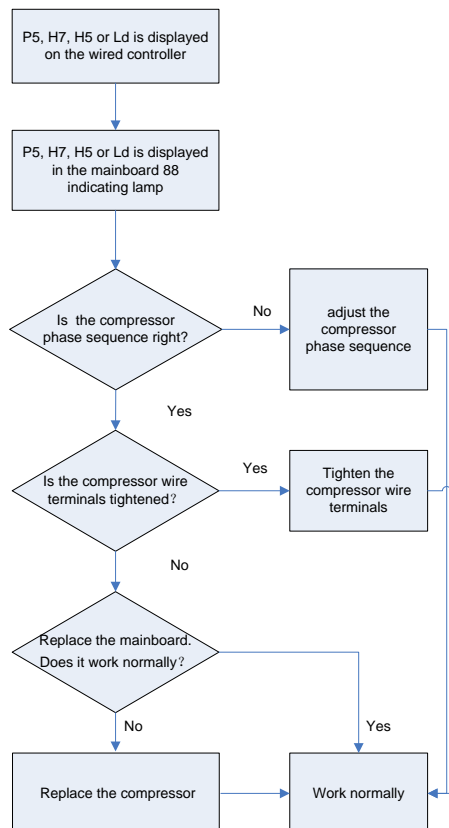



◆ PU Charging circuit error

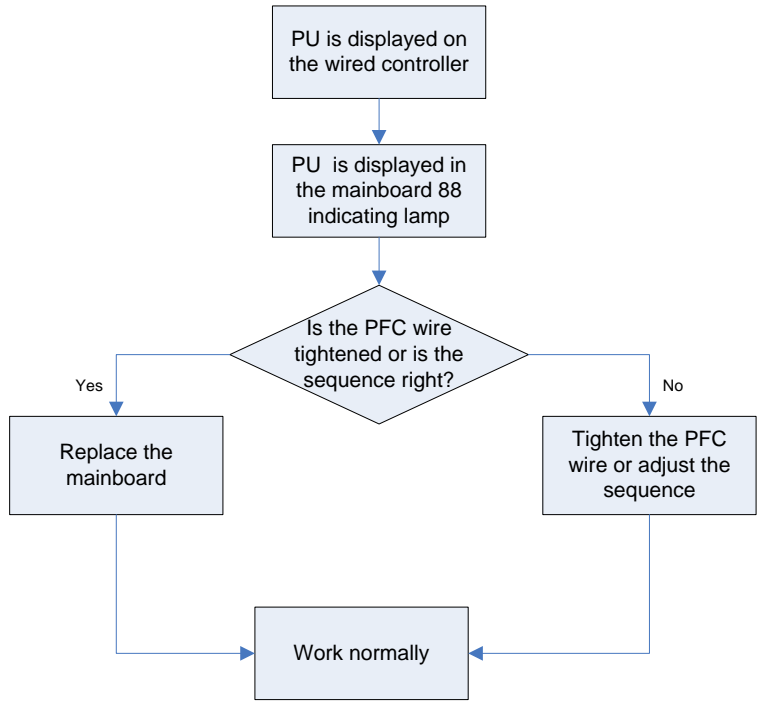

◆ ee driving board chip error

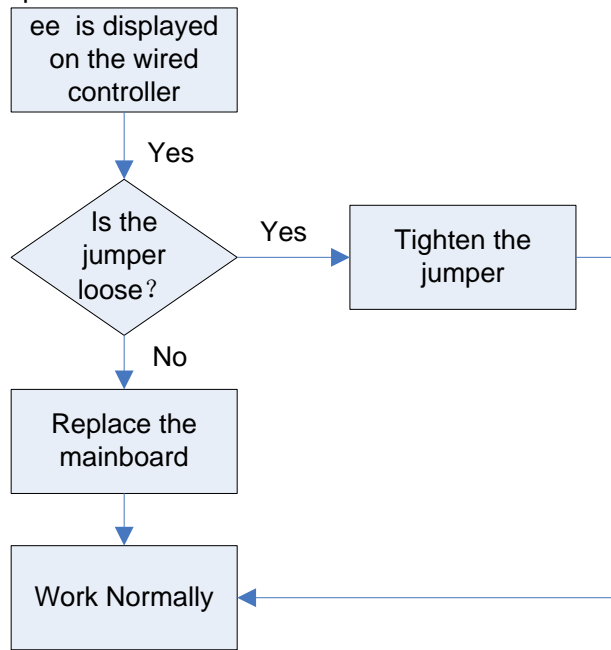

◆ H6 DC fan error

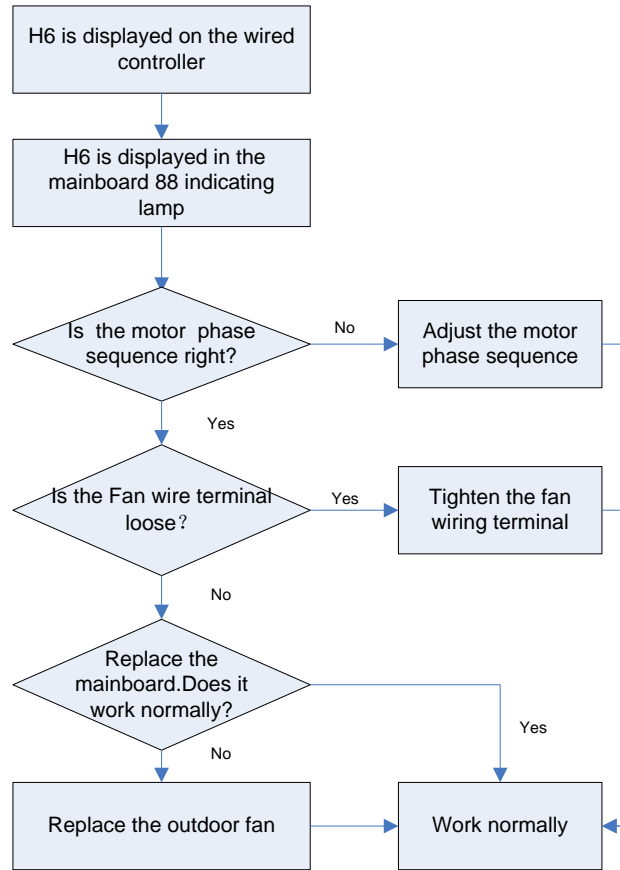

## 2.3 Interface

◆ Outdoor units Main Control Board

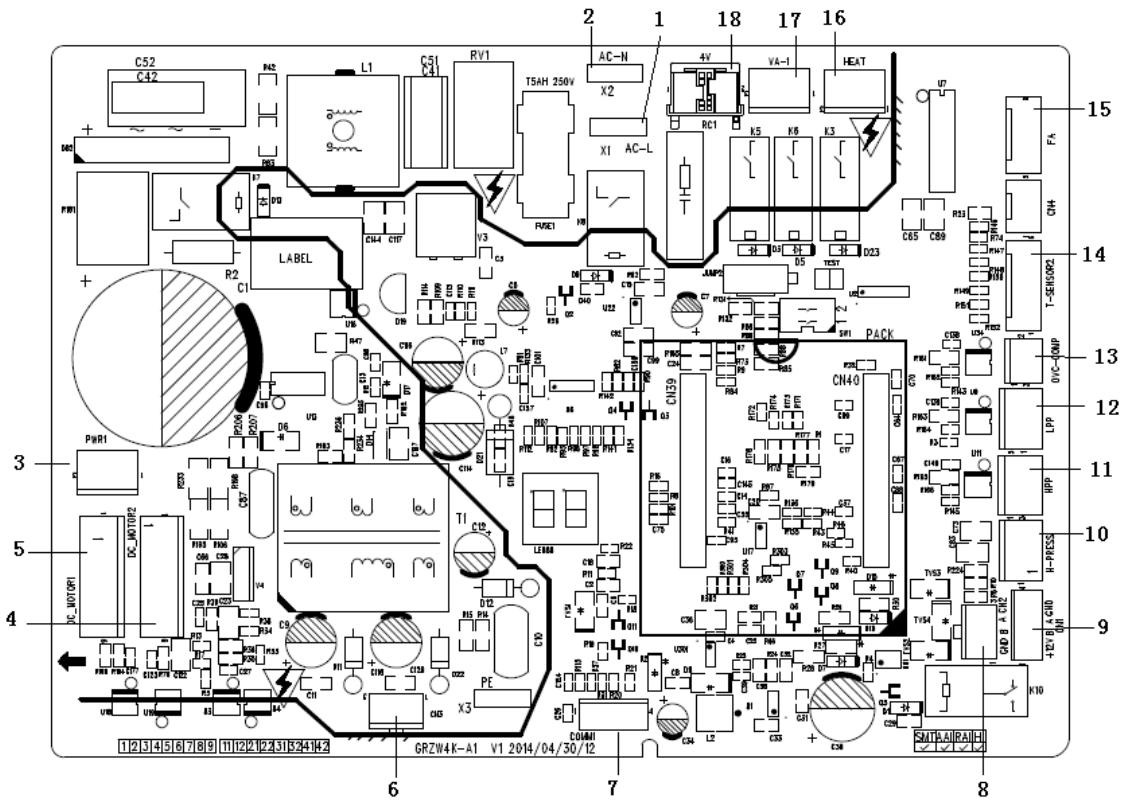

NO.	SILK-SCREEN	INTERFACE	INTERFACE INSTRUCTION
1	AC-L	Live wire input	Live wire input
2	AC-N	Neutral wire input	Neutral wire input
3	PWR 1	Control power output[1- DC bus voltage,3- GND]	Power supply interface to the drive 1-pin: DC bus voltage 3-pin: DC bus GND
4	DC_MOTOR2	DC fan motor2 1-pin: Power supply of fan motor 3-pin: Fan GND 4-pin: +15V 5-pin: Signal control 6-pin: NC	Interface of DC fan motor 1-pin: DC bus voltage 2-pin: Suspended 3-pin: DC bus GND 4-pin: +15V 5-pin: Control signal input 6-pin: Not connected
5	DC_MOTOR1	DC fan motor1 1-pin: Power supply of fan motor 3-pin: Fan GND 4-pin: +15V 5-pin: Signal control 6-pin: Signal Feedback	Interface of DC fan motor 1-pin: DC bus voltage 2-pin: Suspended 3-pin: DC bus GND 4-pin: +15V 5-pin: Control signal input 65-pin: DC fan motor feedback
6	CN3	Control power output[1-GND、 2-18V、 3-15V]	Power supply interface to the drive 1-pin: GND 2-pin: +18V 3-pin: +15V
7	COMM1	Communication line [1-3.3V、 2-TX、 3-RX、 4-GND]	Communication needle stand of main control drive 1-pin: +3.3V、 2-pin: TXD 3-pin: RXD、 4-pin: GND
8	CN2	Communication line with1-pin GND, 2-pin B and 3-pinA)	Communication needle stand with indoor unit 1-pin: GND, 2-pin: B, 3-pin: A
9	CN1	Communication line with 1-pin plus 12V, 2-pin B, 3-pin A and 4-pin GND	Communication interface (reserved): 1-pin: +12V, 2-pin: B, 3-pin: A, 4-pin: GND
10	H-PRESS	High pressure switch for fan speed adjustment	Pressure protection switch for fan speed adjustment
11	HPP	High pressure switch for system protection (obligate)	Interface of high pressure protection
12	LPP	Low pressure switch for system protection (obligate)	Interface of low pressure protection
13	OVC-COMP	Compressor overload protection	Interface of compressor overload protection
14	T-SENSOR2	1&2 pin: Tube sensor 3&4 pin: Ambient temperature 5&6 pin: Air discharge	1&2 pin: Case temperature sensor 3&4 pin: Ambient temperature sensor 5&6 pin: Discharge temperature sensor
15	FA	Electronic expansion valve line 1 to 4-pin: Drive impulse output;5-pin: +12V;	Interface of electronic expansion valve: 1 to 4-pin: Drive impulse output; 5-pin: +12V;
16	HEAT	Compressor electrical heater	Compressor electric heating belt
17	VA-1	Chassis electrical heater	Chassis electric heating belt
18	4V	4-way valve	4-way valve

◆ GUHD24NS3GO/GUHD36NS3GO

(1) Driving Board

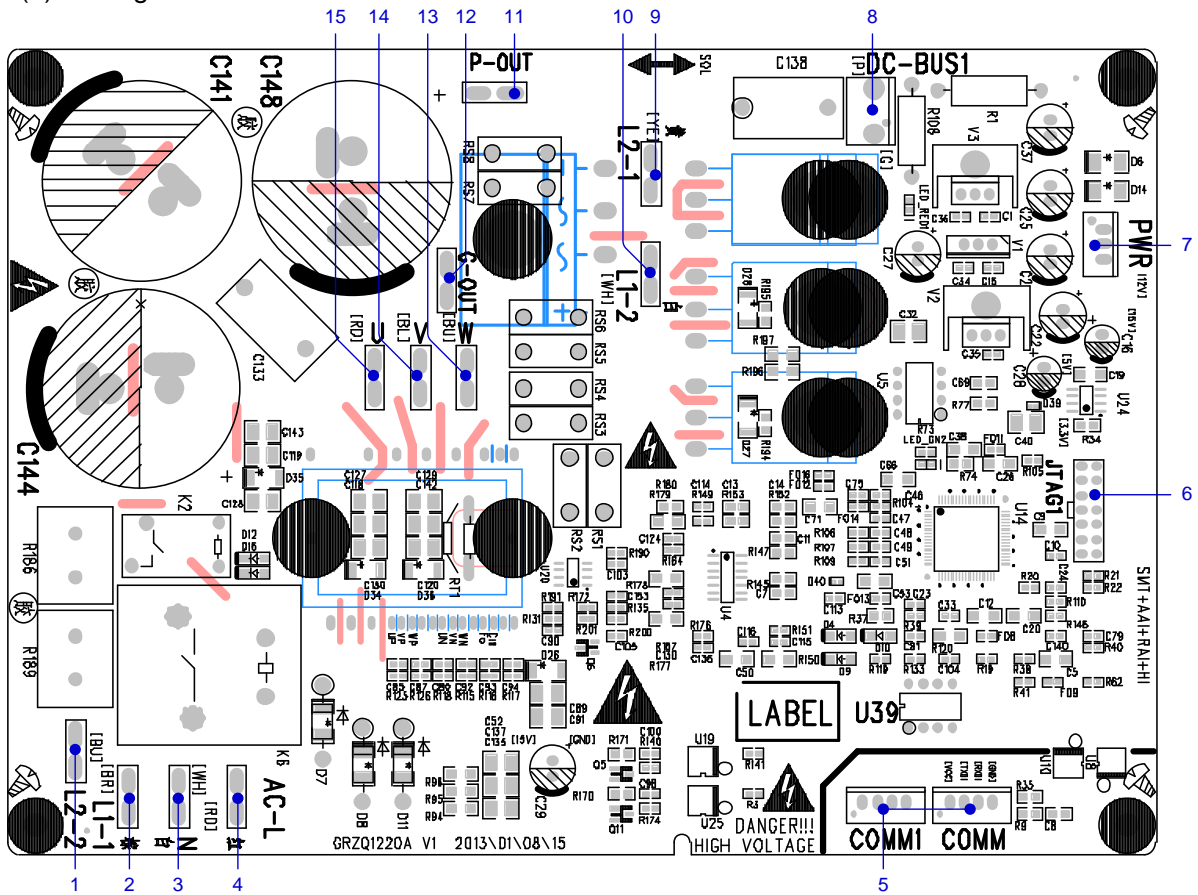

No.	Printing	Interface	No.	Printing	Interface
1	L2_2	PFC induction wire (blue)	2	L1_1	PFC induction wire (brown)
3	N	Neutral wire input (white)	4	AC-L	Live wire input (red)
5	COMM/COMM1	Communication interface	6	JTAG1	(Reserved)
7	PWR	Control power input	8	DC-BUS1	Bus electric discharging interface (for testing)
9	L2-1	PFC induction wire (yellow)	10	L1-2	PFC induction wire (white)
11	P-OUT	(Reserved)	12	G-OUT	(Reserved)
13	W	Compressor Phase W	14	V	Compressor Phase V
15	U	Compressor Phase U			

(2) Filtering Board

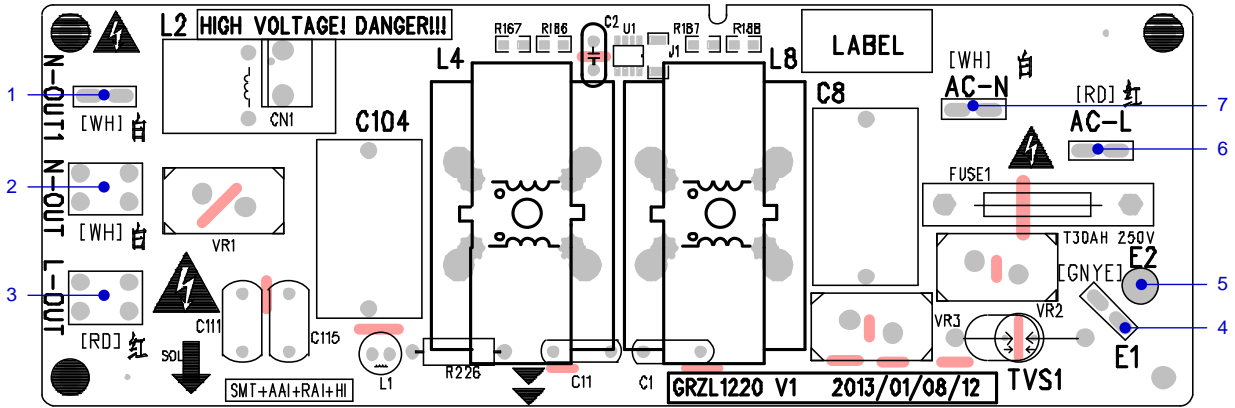

No.	Printing	Interface	No.	Printing	Interface
1	N-OUT1	Neutral wire output 1 (white)	2	N-OUT	Neutral wire output (white)
3	L-OUT	Live wire output (red)	4	E1	Grounding wire
5	E2	(Reserved)	6	AC-L	Live wire input (red)
7	AC-N	Neutral wire input (white)			

◆ GUHD42NS3GO/GUHD48NS3GO/GUHD60NS3GO

(1) Drive Board:

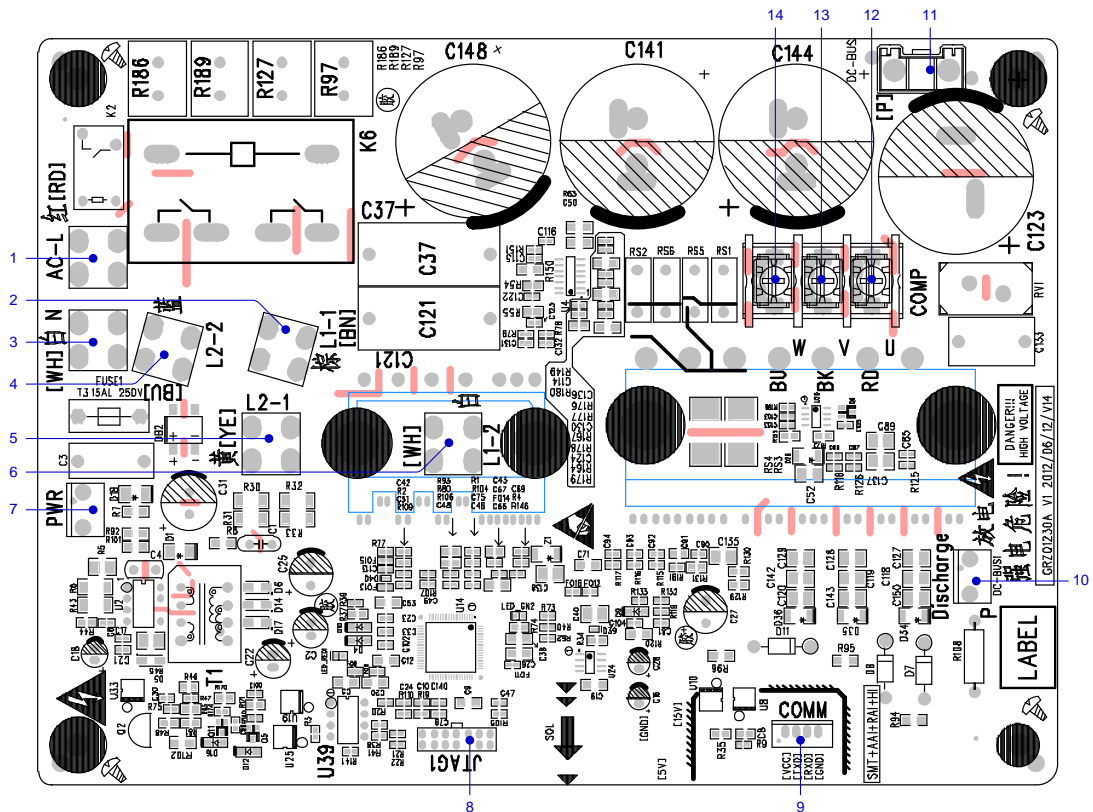

No.	Printing	Interface	No.	Printing	Interface
1	AC-L	Live wire input (red)	2	L1-1	PFC induction wire (brown)
3	N	Neutral wire input (white)	4	L2-2	PFC induction wire (blue)
5	L2-1	PFC induction wire (yellow)	6	L1-2	PFC induction wire (white)
7	PWR	Control power input	8	JTAG1	(Reserved)
9	COMM	Communication interface	10	DC-BUS1	DC bus electric discharging needle stand (for testing)
11	DC-BUS	DC bus interface (connect to filtering board)	12	U	Compressor Phase U
13	V	Compressor Phase V	14	W	Compressor Phase W

(2) Filtering Board:

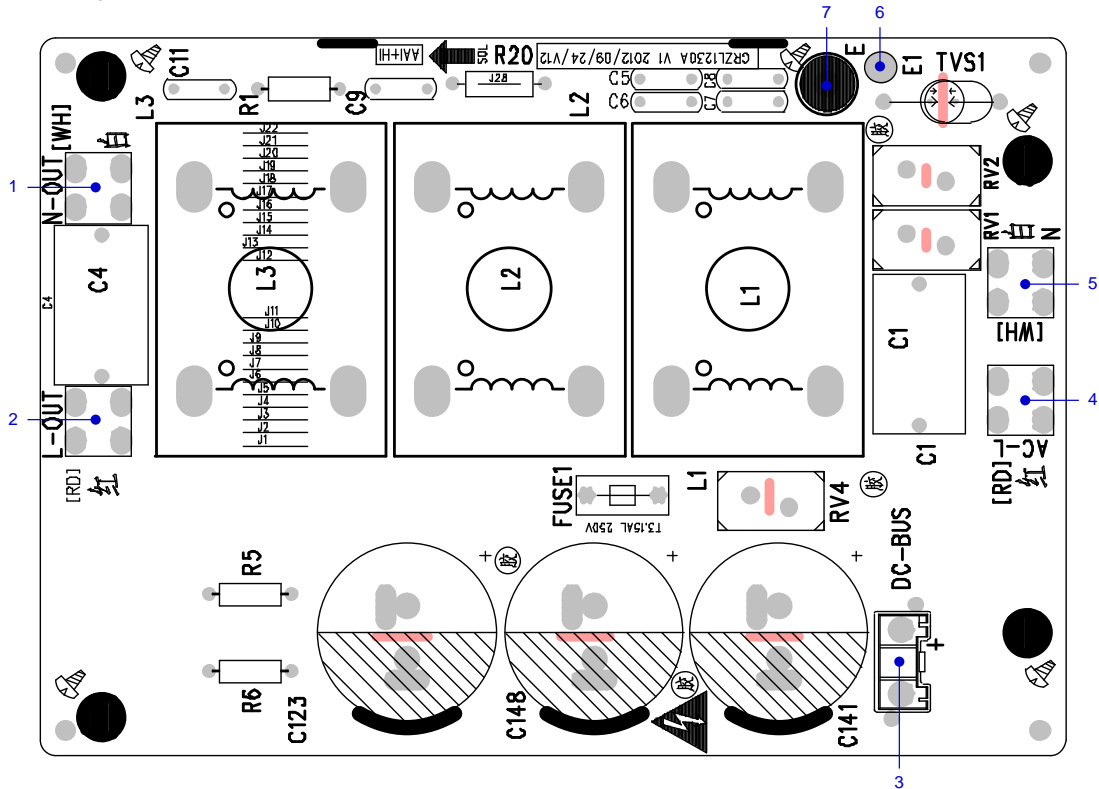

No.	Printing	Interface	No.	Printing	Interface
1	N-OUT	Neutral wire output (white)	2	L-OUT	Live wire output (red)
3	DC-BUS	DC bus interface (connect to drive board)	4	AC-L	Live wire input (red)
5	N	Neutral wire input (white)	6	E1	(Reserved)
7	E	Grounding wire (screw hole)			

## 2.4 IPM, PFC Testing Method

### 2.4.1 Method of Testing IPM Module

(1) Preparation before test: prepare a universal meter and turn to its diode option, and then remove the wires U, V, W of the compressor after it is powered off for one minute.

(2) Testing Steps

Step 1: put the black probe on the place P and the red one on the wiring terminal U, V, W respectively as shown in the following figure to measure the voltage between UP, VP and WP.

Step 2: put the red probe on the place N and the black one on the wiring terminal U, V, W respectively as shown in the following figure to measure the voltage between NU, NV and NW.

(3) If the measured voltages between UP, VP, WP, NU, NV, NW are all among 0.3V-0.7V, then it indicates the IPM module is normal; If any measured value is 0, it indicates the IPM is damaged.

### 2.4.2 Method of Testing PFC Module Short Circuit

**Note:** only for GUHD42NS3GO/GUHD48NS3GO/GUHD60NS3GO)

(1) Preparation before test: prepare a universal meter and turn to its diode option, and then remove the wires L1-2, L2-1 after it is powered off for one minute.

(2) Testing Steps

Step 1: put the black probe on the place P and the red one on the wiring terminal L1-2,

L2-1 respectively as shown in the following figure to measure the voltage between L1-2P and L2-1 P.

Step 2: put the red probe on the place N and the black one on the wiring terminal L1-2, L2-1 respectively as shown in the following figure to measure the voltage between N L1-2 and NL2-1.

(3) If the measured voltages between L1-2P ,L2-1 P, N L1-2 , NL2-1 are all among 0.3V-0.7V, then it indicates the PFC module is normal; If any measured value is 0, it indicates the PFC is damaged.

◆ GUHD24NS3GO/GUHD36NS3GO

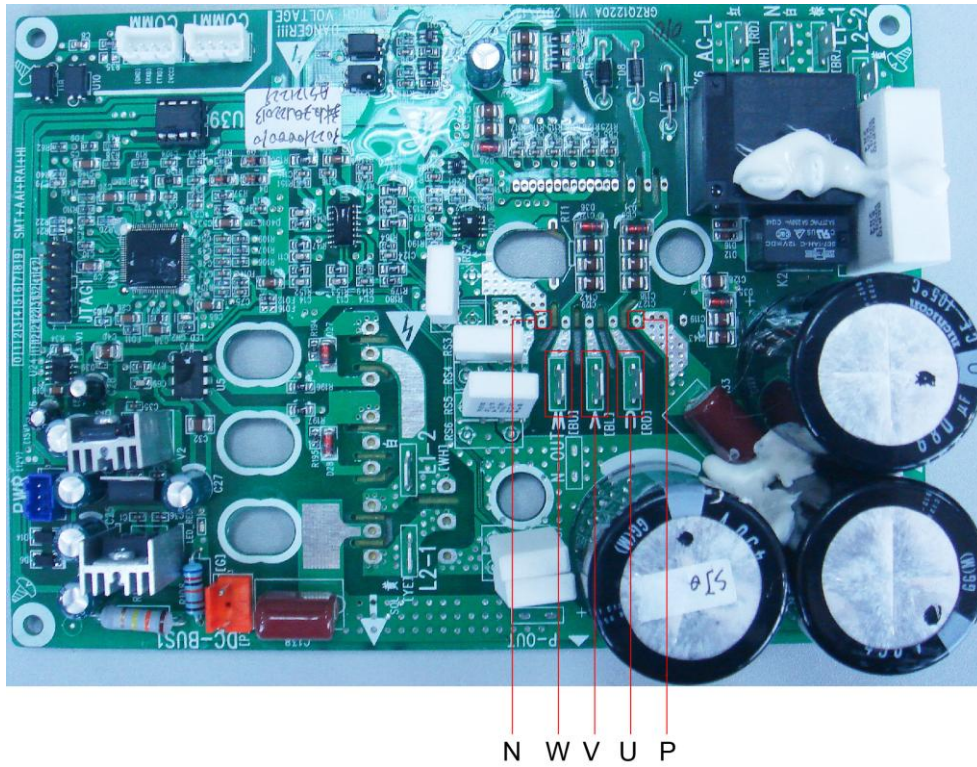

◆ GUHD42NS3GO/GUHD48NS3GO/GUHD60NS3GO

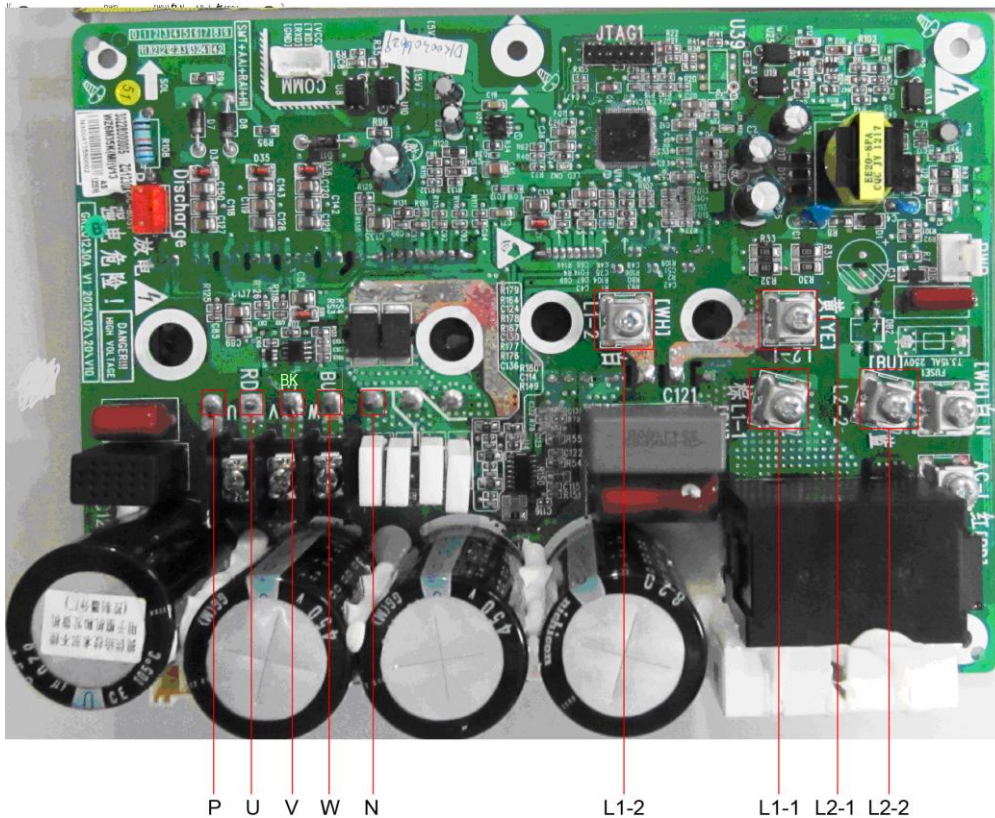

# 3 WIRING DIAGRAM

## 3.1 Outdoor unit

The actual wiring should always refer to the wiring diagram of the unit.

Model: GUHD24NS3GO

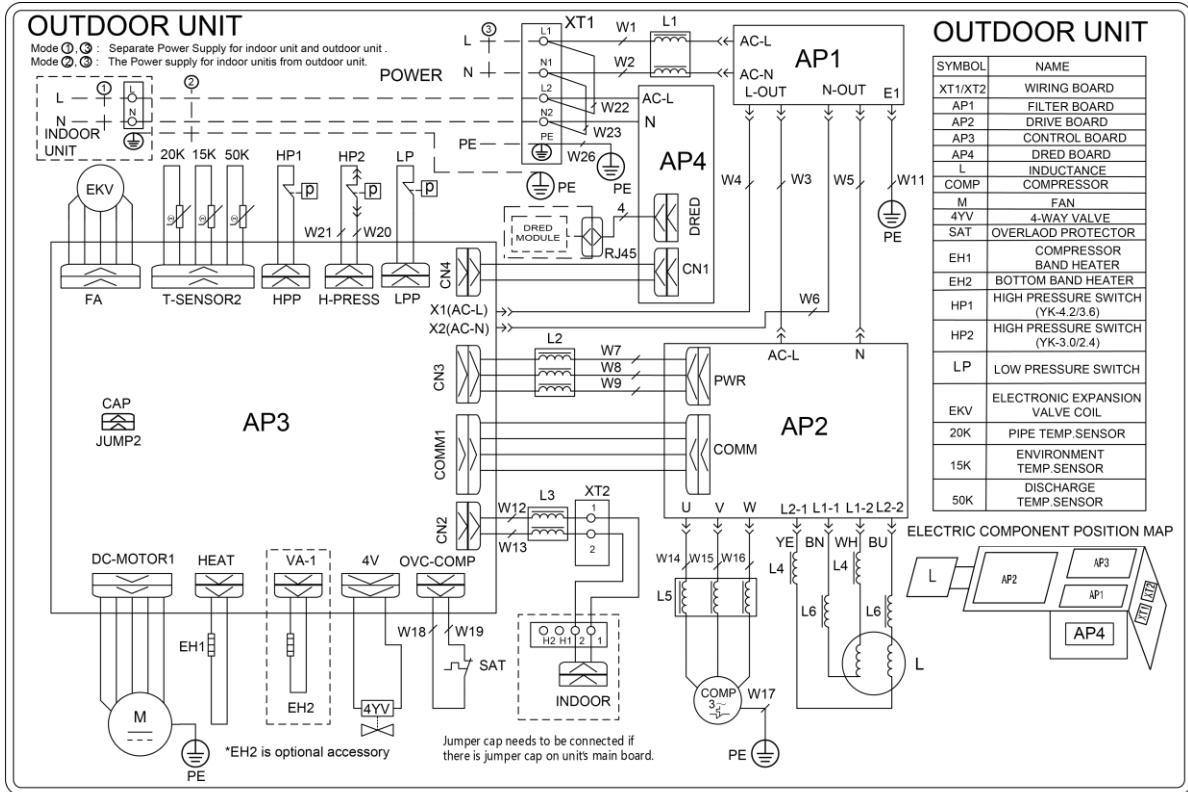

Model: GUHD36NS3GO

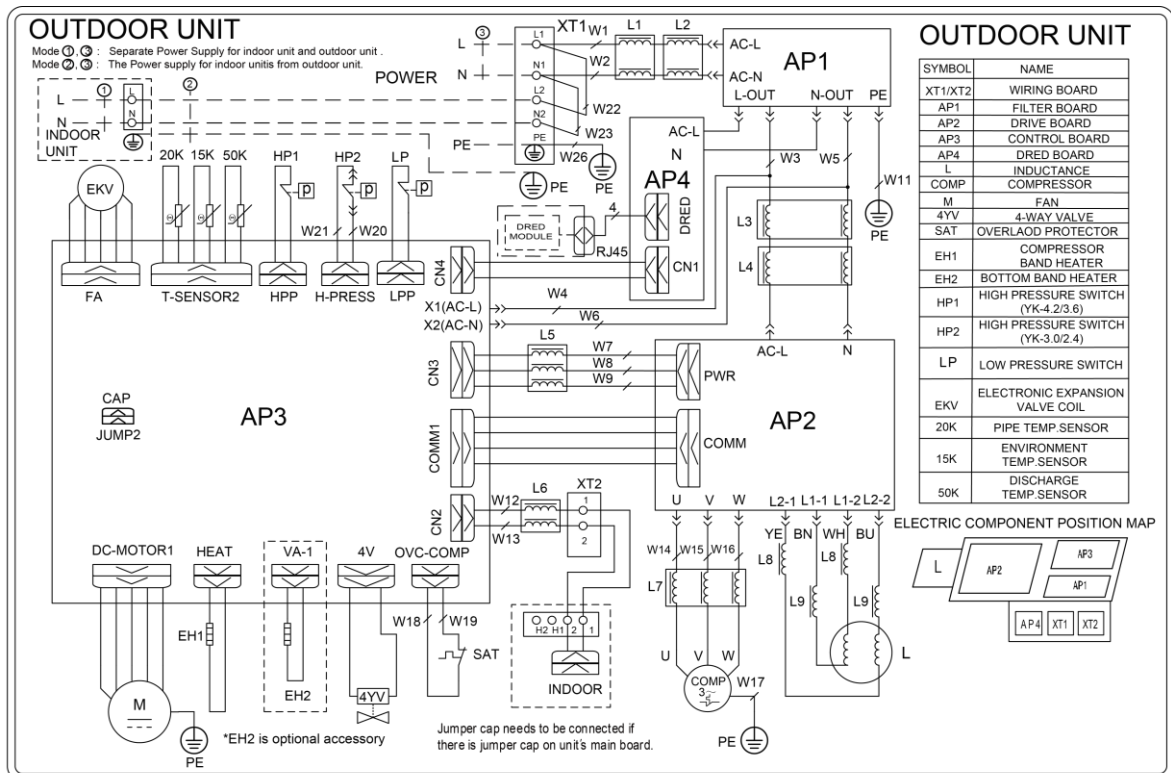



Model: GUHD42NS3GO

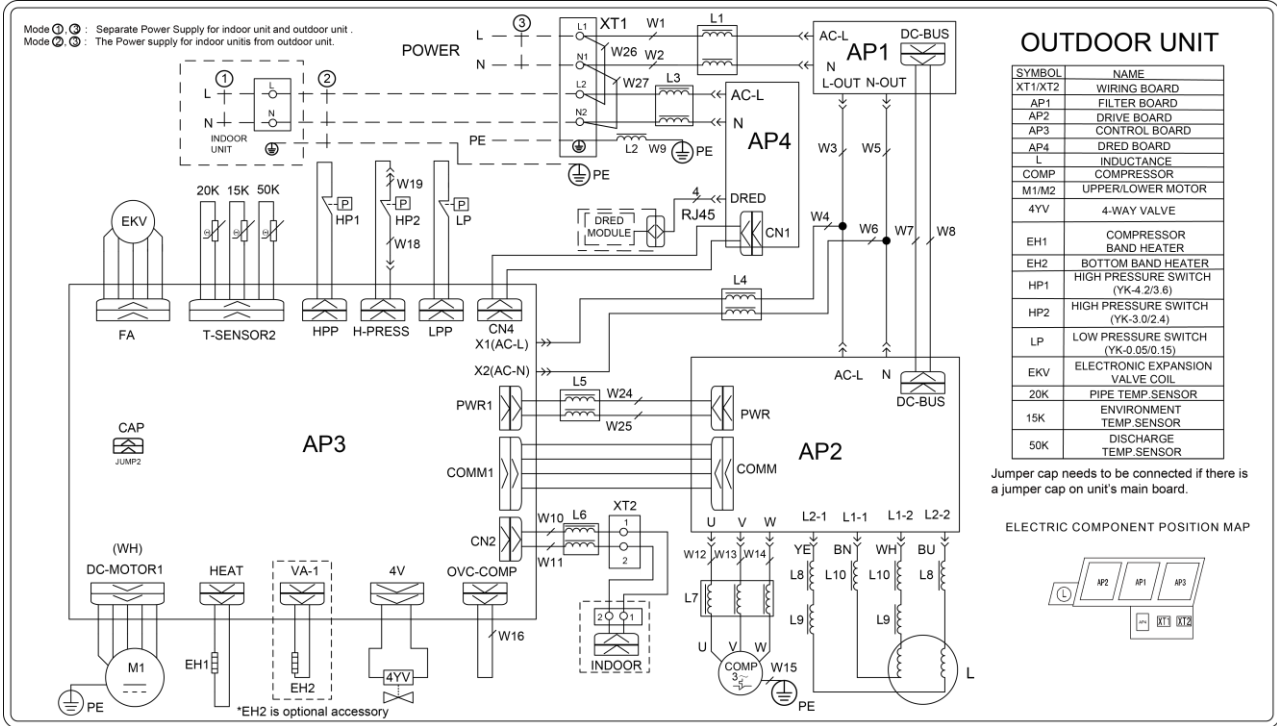

Model: GUHD48NS3GO/GUHD60NS3GO

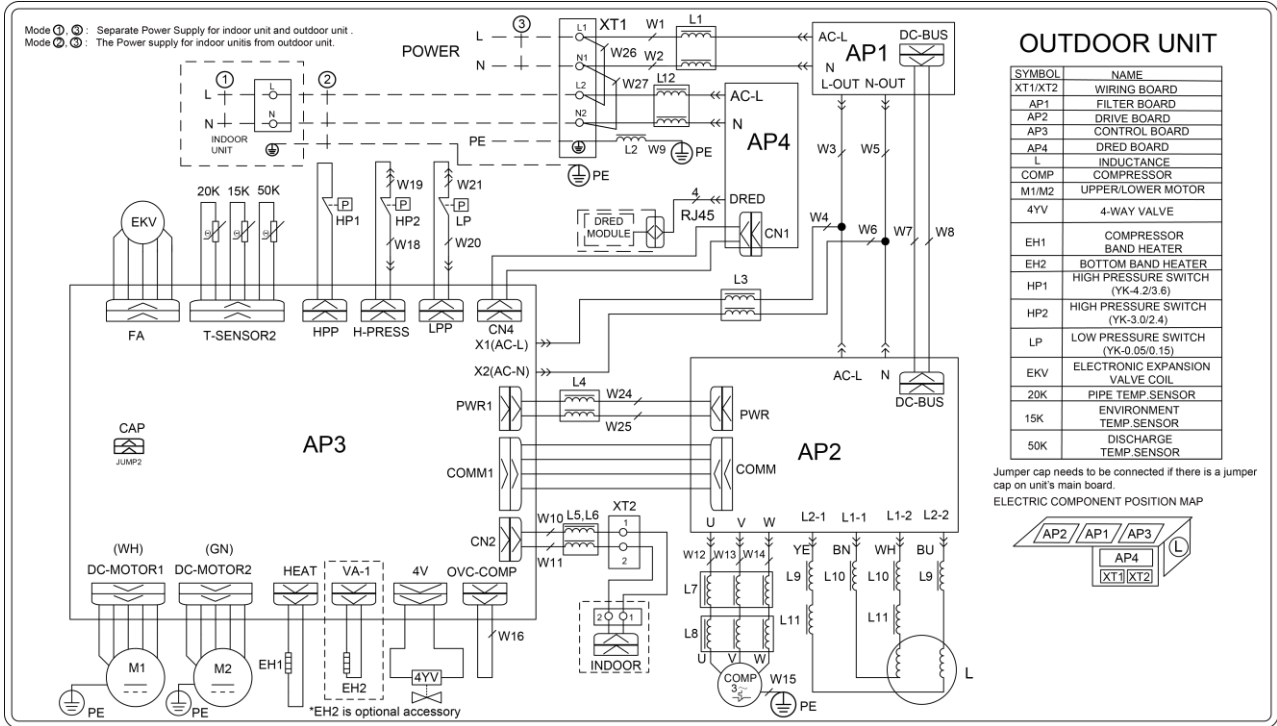

### 3.2 Indoor unit

The actual wiring should always refer to the wiring diagram of the unit.

#### 3.2.1 Duct Type

◆ Model: GFH24S3GI

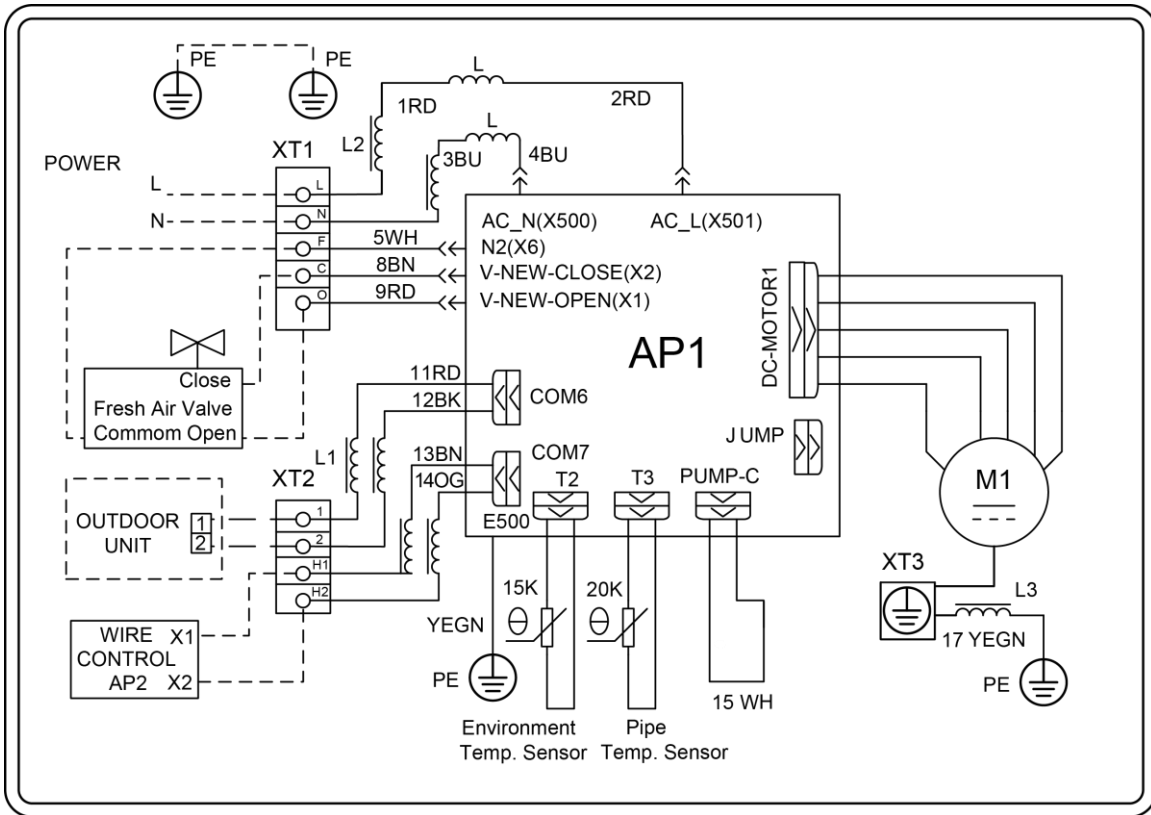

◆ GFH24S3G1I

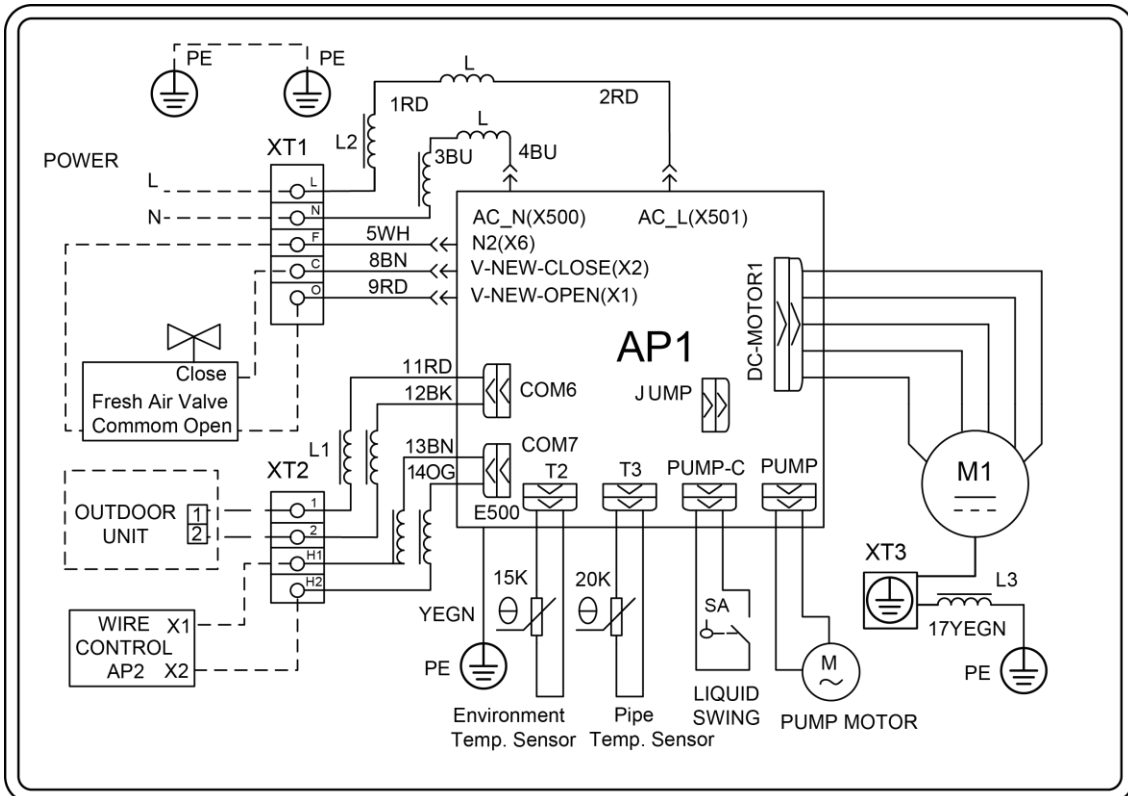

◆ Model: GFH36S3GI/GFH42S3GI/GFH48S3GI/GFH60S3GI

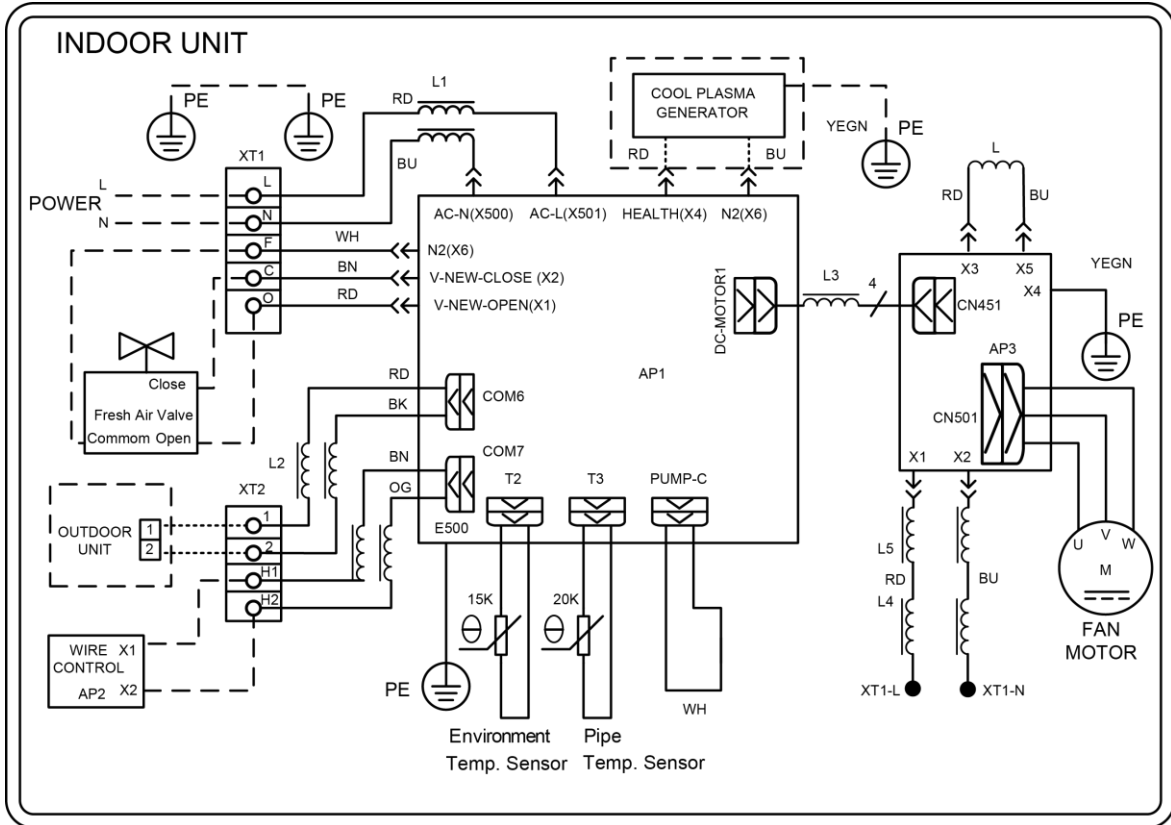

◆ Model: GFH36S3G11/GFH42S3G11/GFH48S3G11/GFH60S3G11

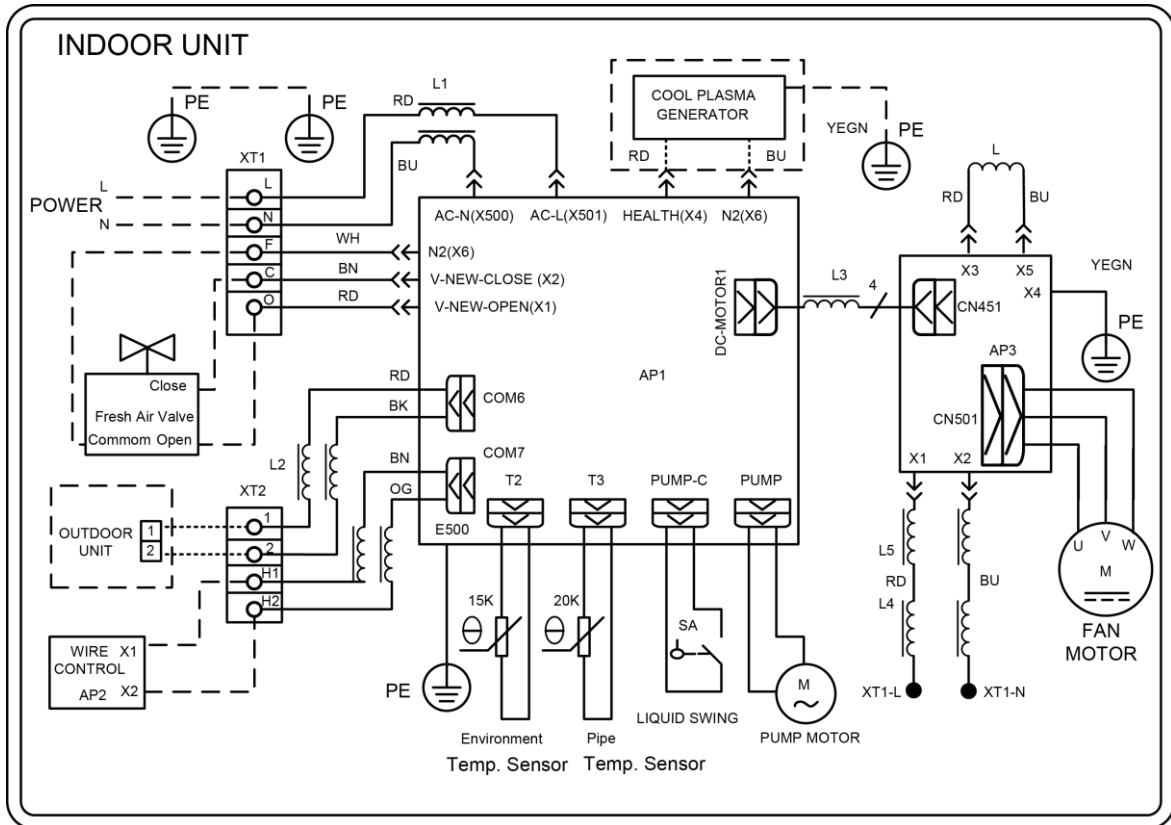

### 3.2.2 Cassette Type

◆ Model: GKH24S3GI/GKH36S3GI/GKH42S3GI

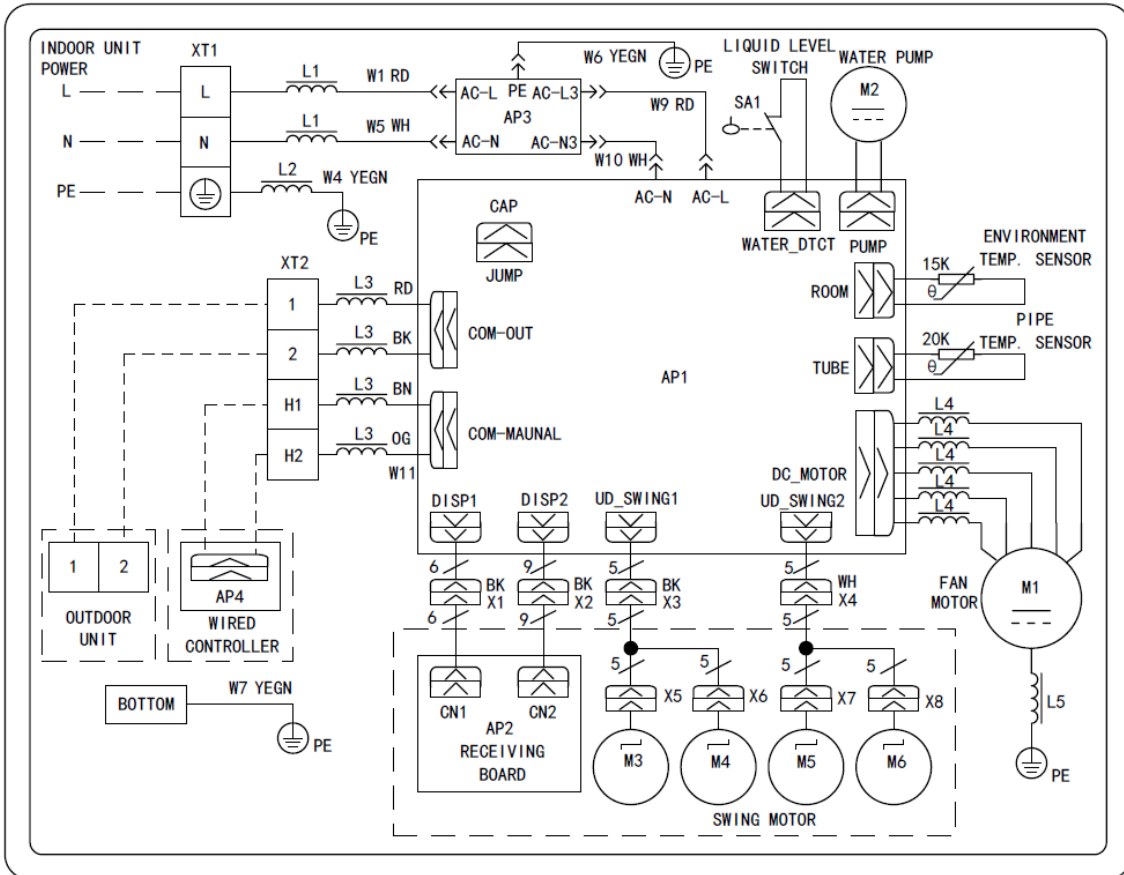

◆ Model: GKH48S3GI

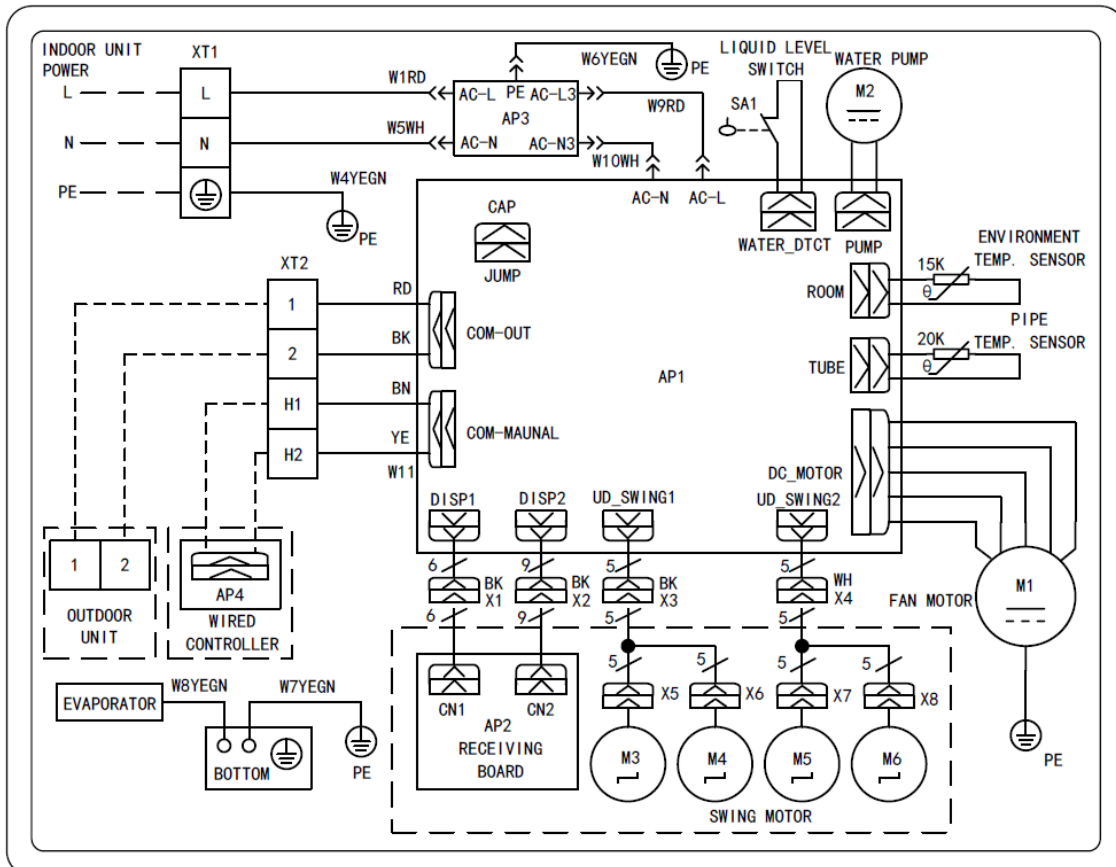

# 4 DISASSEMBLY AND ASSEMBLY PROCEDURE OF MAIN PARTS

## 4.1 Outdoor Unit

24k

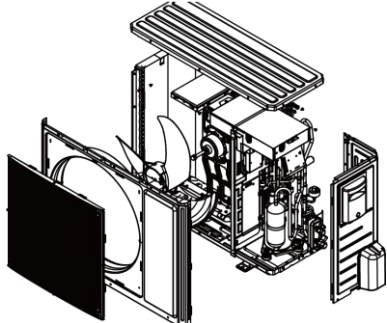
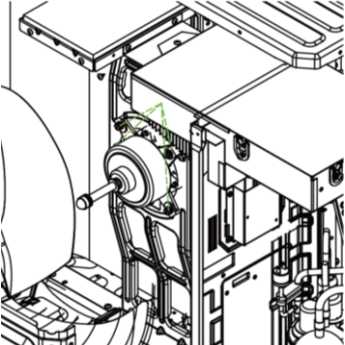
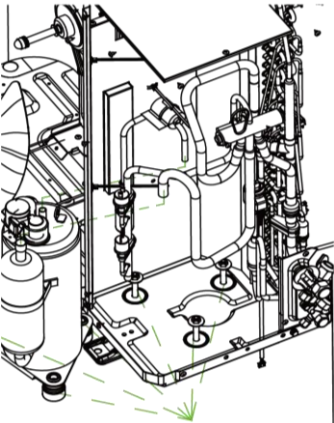
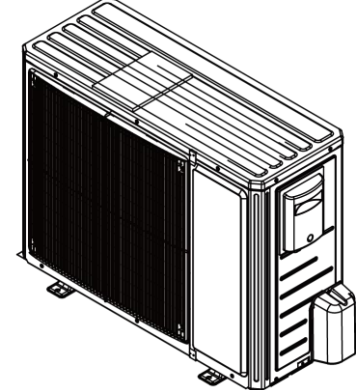
Disassembly and Assembly of external casing		
Remark :		
Step	Illustration	Handling Instruction
1. Remove external casing		<ol style="list-style-type: none"> <li>1. Remove the top cover and handle;</li> <li>2. Remove the grille, outer case, front side plate and right side plate.</li> </ol>
2. Remove motor		<ol style="list-style-type: none"> <li>1. Remove the blade nut and then remove the blade;</li> <li>2. Remove the motor from motor support.</li> </ol>
3. Remove compressor		<ol style="list-style-type: none"> <li>1. Discharge the refrigerant inside the pipeline and recycle the refrigerant during discharging;</li> <li>2. Unsolder the 4-way valve assy from compressor;</li> <li>3. Remove the nut fixing compressor;</li> <li>4. Take away the compressor from chassis.</li> </ol>
4. Assemble unit		Assemble the unit in the reverse procedures of disassembly.

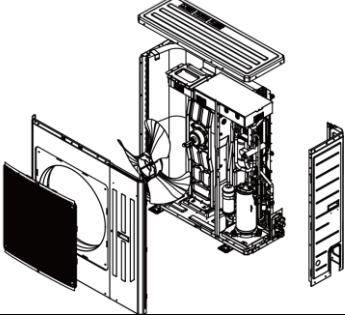
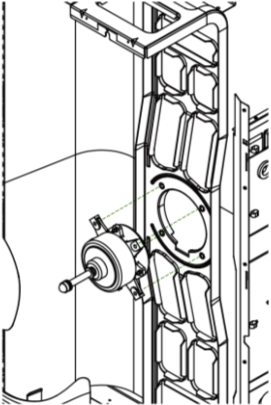
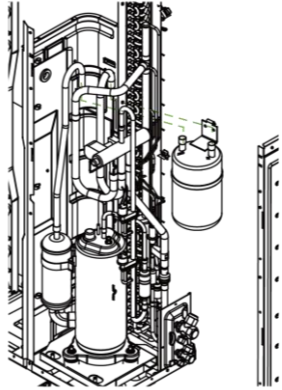
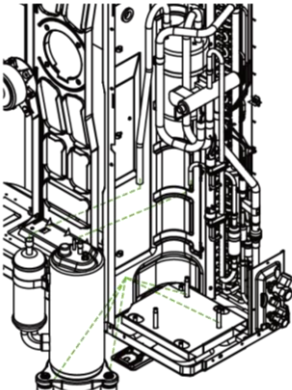

36/42k

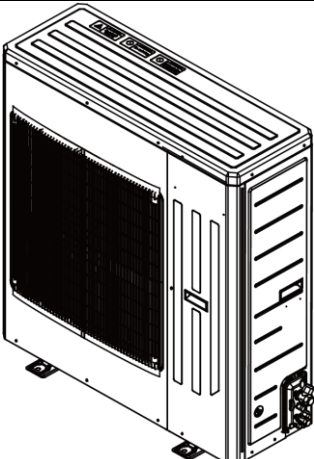
Disassembly and Assembly of external casing		
Remark :		
Step	Illustration	Handling Instruction
1. Remove external casing		<ol style="list-style-type: none"> <li>1. Remove the top cover and handle;</li> <li>2. Remove the grille, outer case and right side plate.</li> </ol>
2. Remove motor		<ol style="list-style-type: none"> <li>1. Remove the blade nut and then remove the blade;</li> <li>2. Remove the motor from motor support.</li> </ol>
3. Remove gas liquid separator		<ol style="list-style-type: none"> <li>1. Discharge the refrigerant inside the pipeline and recycle the refrigerant during discharging;</li> <li>2. Unsolder the 4-way valve assy from gas liquid separator;</li> <li>3. Remove the gas liquid separator.</li> </ol>
4. Remove compressor		<ol style="list-style-type: none"> <li>1. Discharge the refrigerant inside the pipeline and recycle the refrigerant during discharging;</li> <li>2. Unsolder the 4-way valve assy from compressor;</li> <li>3. Remove the nut fixing compressor;</li> <li>4. Take away the compressor from chassis.</li> </ol>

<p>5. Assemble unit</p>		<p>Assemble the unit in the reverse procedures of disassembly.</p>
-------------------------	---	--

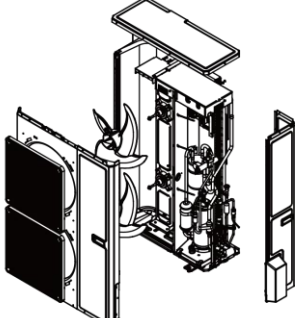
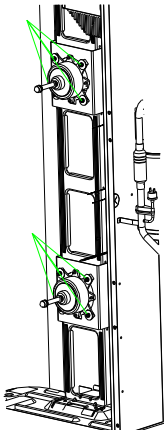
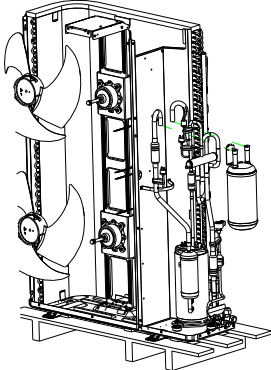
48/60k:

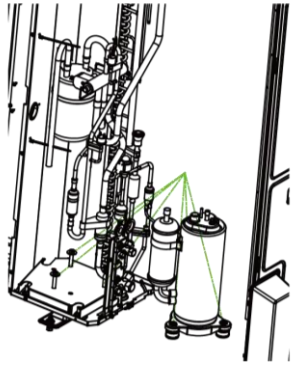
Disassembly and Assembly of external casing		
Remark :		
Step	Illustration	Handling Instruction
<p>1. Remove external casing</p>		<p>1. Remove the top cover and handle; 2. Remove the grille, outer case and right side plate.</p>
<p>2. Remove motor</p>		<p>1. Remove the blade nut and then remove the blade; 2. Remove the motor from motor support.</p>
<p>3. Remove gas liquid separator.</p>		<p>1. Discharge the refrigerant inside the pipeline and recycle the refrigerant during discharging; 2. Unsolder the 4-way valve assy from gas liquid separator; 3. Remove the gas liquid separator.</p>

<p>4. Remove compressor</p>		<ol style="list-style-type: none"> <li>1. Discharge the refrigerant inside the pipeline and recycle the refrigerant during discharging;</li> <li>2. Unsolder the 4-way valve assy from compressor;</li> <li>3. Remove the nut fixing compressor;</li> <li>4. Take away the compressor from chassis.</li> </ol>
<p>5. Assemble unit</p>		<p>Assemble the unit in the reverse procedures of disassembly.</p>

## 4.2 Indoor Unit

### 4.2.1 Duct type

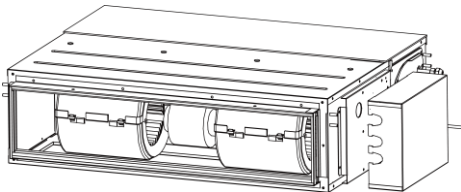
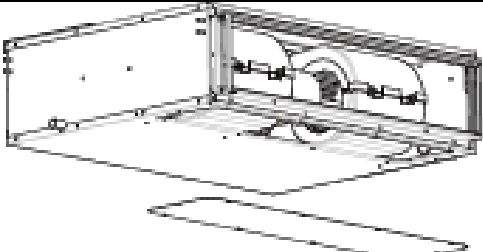
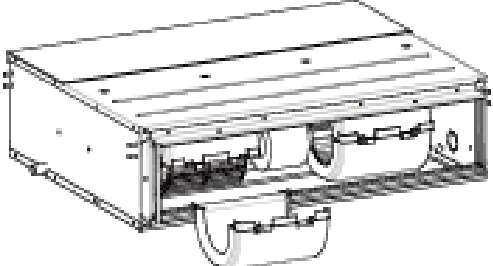
Removal and Assembly of Fan Motor		
Remarks: Before removing the fan, make sure to cut off the power firstly.		
Step	Illustration	Handling Instruction
<p>1. Unplug the motor cables</p>		<p>Cut off the power supply of indoor unit. Use screwdriver to remove the electric box cover and unplug the motor cables in electric box.</p>
<p>2. Remove the filter sub-assembly and air inlet cover board</p>		<p>Remove the filter sub-assembly from the air inlet frame and use screwdriver to remove the air inlet cover board.</p>
<p>3. Remove the screws on fan sub-assembly.</p>		<p>Remove the screws on fan sub-assembly.</p>

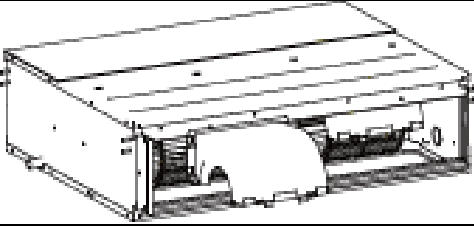
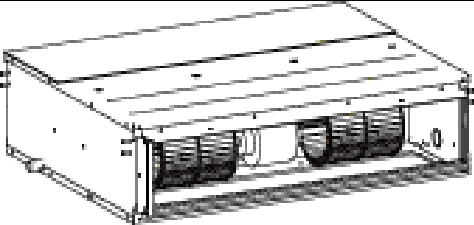
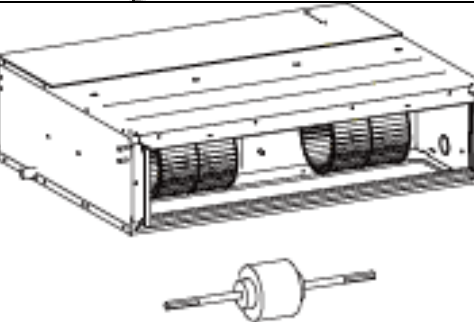
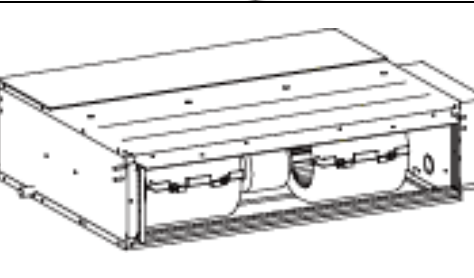

<p>4. Overturn the propeller housing</p>		<p>Rotate the propeller housing to the air inlet according to arrow direction.</p>
<p>5. Loosen the fan and motor.</p>		<p>Use inner hexagonal spanner to loosen the screws on fan and remove the clamp fixing the motor.</p>
<p>6. Replace the motor</p>		<p>Firstly, disengage the motor from motor support. Then, sequentially disengage the fan sub-assembly from the motor shaft. Remove the motor from the air inlet and replace with new motor. In which, for the motor with automatic motor support, the motor support shall be removed in advance and then changed to the unit.</p>
<p>7. Assemble the unit in reverse to the disassembly procedures</p>		<p>Assemble the unit in reverse to the disassembly procedures and energize it for testing.</p>

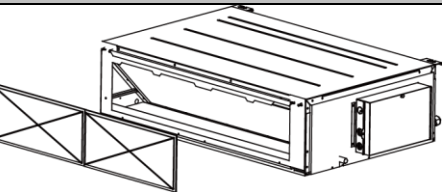
<p>Disassembly of filter screen for return air</p>		
<p>Remark: Make sure that the power supply is cut off before disassembling and protect all the parts during disassembly. Do not put filter screen near the high temperature heat source.</p>		
<p>Step</p>	<p>Illustration</p>	<p>Handling Instruction</p>
<p>1. Disassembly of filter screen for return air</p>		<p>Compress the filter screen for return air down on the guide slot sponge, and remove according to the direction shown by the arrow. There are 2 filter screen for return air.</p>

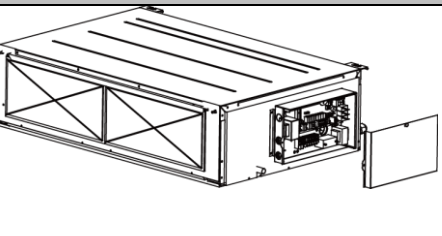
<p>Disassembly of electrical parts box cover panel and electrical parts box</p>		
<p>Remark: Make sure that the power supply is cut off before disassembling and protect all the parts during disassembly, especially the electrical components. Do not dampen or hit them.</p>		
<p>Step</p>	<p>Illustration</p>	<p>Handling Instruction</p>
<p>1. Disassembly of electric box cover</p>		<p>Disassemble the screw according to the position shown in the circle and the box and remove the electric box in the direction of the arrow.</p>

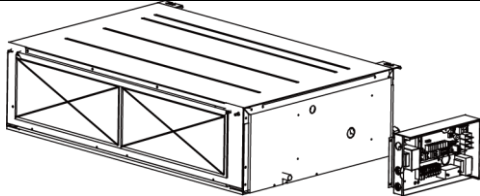
<p>2. Disassembly of electric parts box</p>		<p>Disassemble the fastening screw and remove the electrical parts box. (As is shown in the graph, there are 2 fastening screws in the circle and the screws in the direction of arrow shall be disassembled too.)</p>
---	---	--

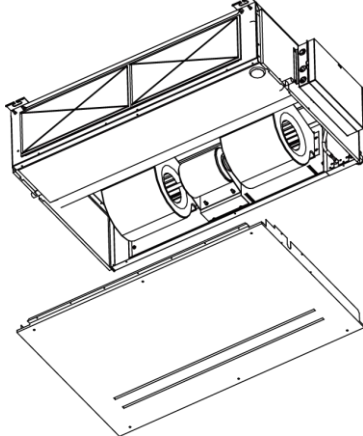
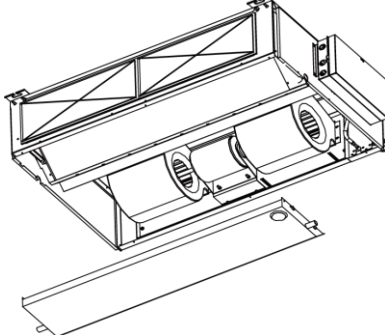
Disassembly of water-containing plate		
Remark: Make sure that the power supply is cut off before disassembling and protect all the parts during disassembly.		
Step	Illustration	Handling Instruction
<p>1. Disassembly of cover plate</p>		<p>Disassemble the fastening screws on the cover plate and remove the cover plate. (As is shown in the graph, circle represents 6 fastening screws under the cover plate and the box represents two fastening screws on water-containing plate symmetrically arranged both on left and right.)</p>
<p>2. Disassembly of water-containing plate</p>		<p>Disassemble the fastening screws on the water-containing plate, pull upward and remove the water-containing plate. Disassembled water-containing plate is shown in the graph.</p>

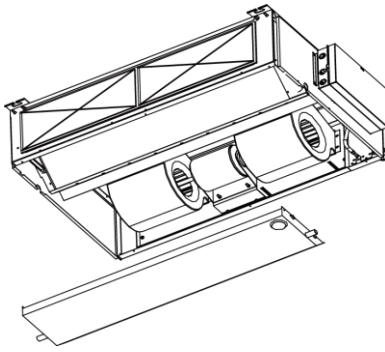
Disassembly of fan and motor		
Remark: Make sure that the power supply is cut off before disassembling and protect all the parts during disassembly.		
Step	Illustration	Handling Instruction
<p>Disassembly of fan motor</p>		<p>Disassemble the fixing screws on the fan components. (As is shown in graph, circle represents 6 screws.) Disassemble the fastening screws on the fan and motor. Remove the fan. (As is shown in the graph, box represents screws.)</p>

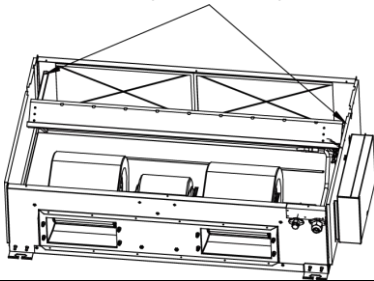
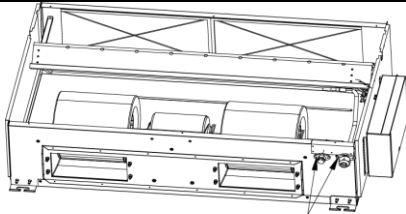
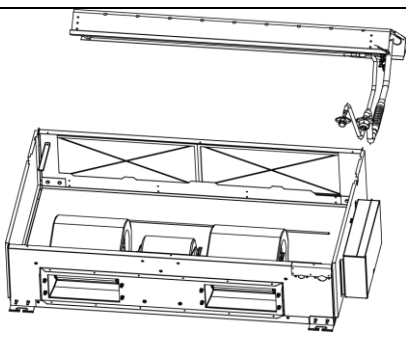
Disassembly of evaporator		
Remark: Make sure that the power supply is cut off and protect the copper tube and aluminum fin. If the time for disassembly shall be long, put the copper tube under pressurized condition.		
Step	Illustration	Handling Instruction
1. Disassembly of fixing screws on the side panels of evaporator	<p>Disassemble of fixing screws on the side panels of evaporator</p> 	Disassemble the fastening screw connecting left and right side panels on the evaporator and the upper cover plate. (As is shown in the arrows direction in graph.)
2. Disassemble fastening screws connecting evaporator valve seal-plate and joint flange	 <p>Disassemble fastening screws connecting evaporator valve seal-plate and joint flange</p>	Disassemble the fastening screws on the valve seal-plate and remove the valve seal-plate. Disassemble the fastening screws on the evaporators joint flange. (As is shown in the graph, box represents fastening screws on seal-plates while circle the fastening screws on joining flange.
3. Removal of evaporator		Remove the evaporator. Removed evaporator is shown in the graph.

### 4.2.2 Cassette-type Unit

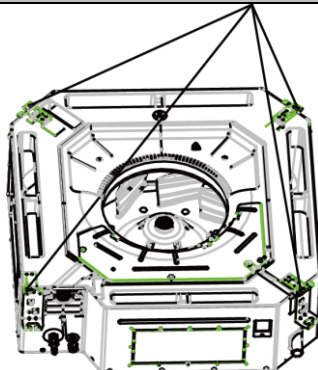
Removal and Assembly of Fan Motor		
Step	Illustration	Handling Instruction
1. Loosen the screws fixing the water tray		Use screwdriver to loosen the screws fixing the water tray.

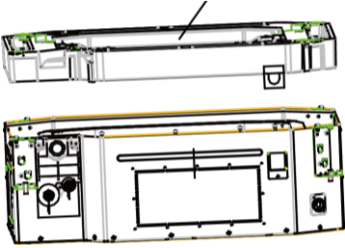
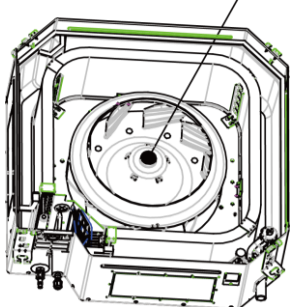
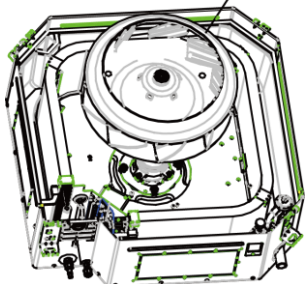
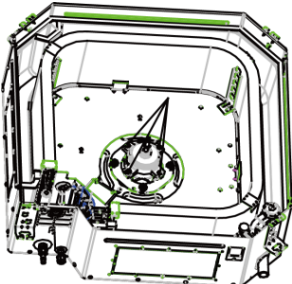
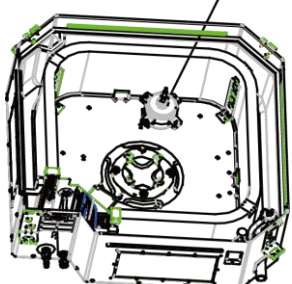
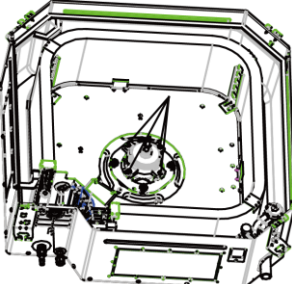
<p>2. Remove the water tray</p>		<p>Remove the water tray.</p>
<p>3. Loosen the bolts fixing the fan</p>		<p>Use spanner to loosen the bolts fixing the fan.</p>
<p>4. Remove the fan</p>		<p>Remove the fan.</p>
<p>5. Loosen the screws fixing the motor</p>		<p>Use screwdriver to loosen the screws fixing the motor.</p>
<p>6. Remove the motor and replace it</p>		<p>Remove the motor and replace it.</p>
<p>7. Tighten the screws fixing the motor</p>		<p>Use screwdriver to tighten the screws fixing the motor.</p>

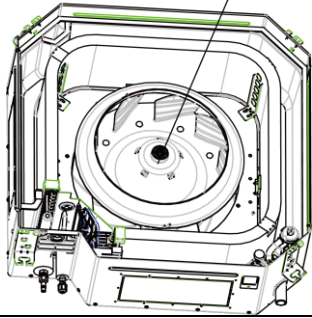
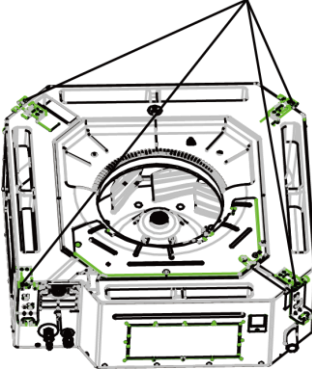
<p>8. Mount the fan and tighten the fixing bolts</p>		<p>Mount the fan and use spanner to tighten the bolts fixing the fan.</p>
<p>9. Mount the water tray and tighten the screws</p>		<p>Use screwdriver to loosen the screws fixing the water tray.</p>

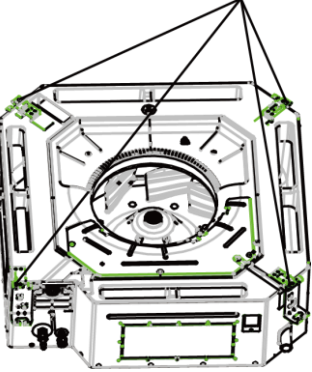
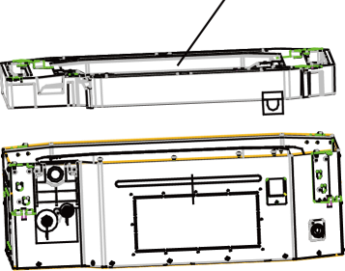
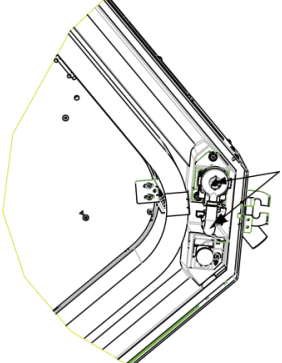
Removal and Installation of Drainage Pump		
Step	Illustration	Handling Instruction
<p>1. Loosen the screws fixing the water tray</p>		<p>Use screwdriver to loosen the screws fixing the water tray.</p>
<p>2. Remove the water tray</p>		<p>Remove the water pump and replace it.</p>
<p>3. Pull out the water outlet pipe and loosen the screws fixing the water pump.</p>		<p>Pull out the water outlet pipe and use screwdriver to loosen the screws fixing the water pump.</p>

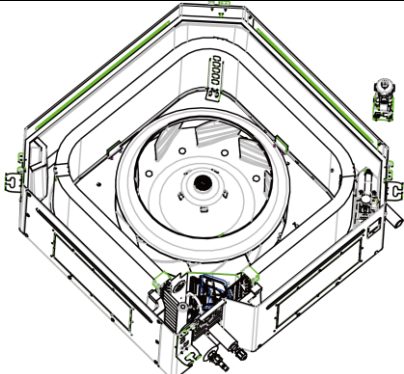
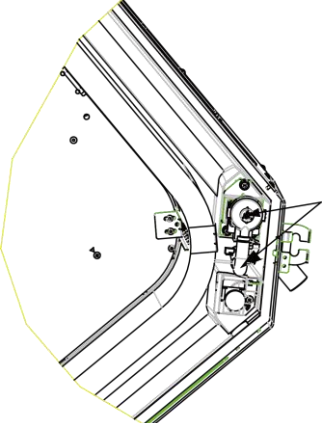
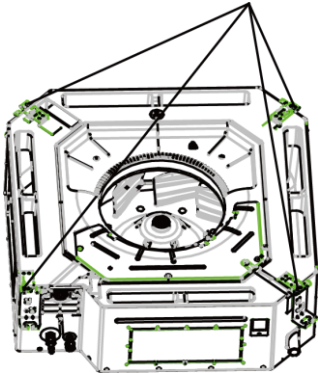
<p>4. Take out the pump and replace it</p>		<p>Take out the pump and replace it</p>
<p>5. Connect the drainage pipe and tighten the screws fixing the water pump.</p>		<p>Connect the drainage pipe and use screwdriver to tighten the screws fixing the water pump.</p>
<p>6. Mount the water tray and tighten the screws</p>		<p>Use screwdriver to loosen the screws fixing the water tray.</p>

# 5 EXPLODED VIEWS AND SPARE PART LIST

## 5.1 Outdoor Unit

◆ Model: GUHD24NS3GO Exploded Views and spare parts list:

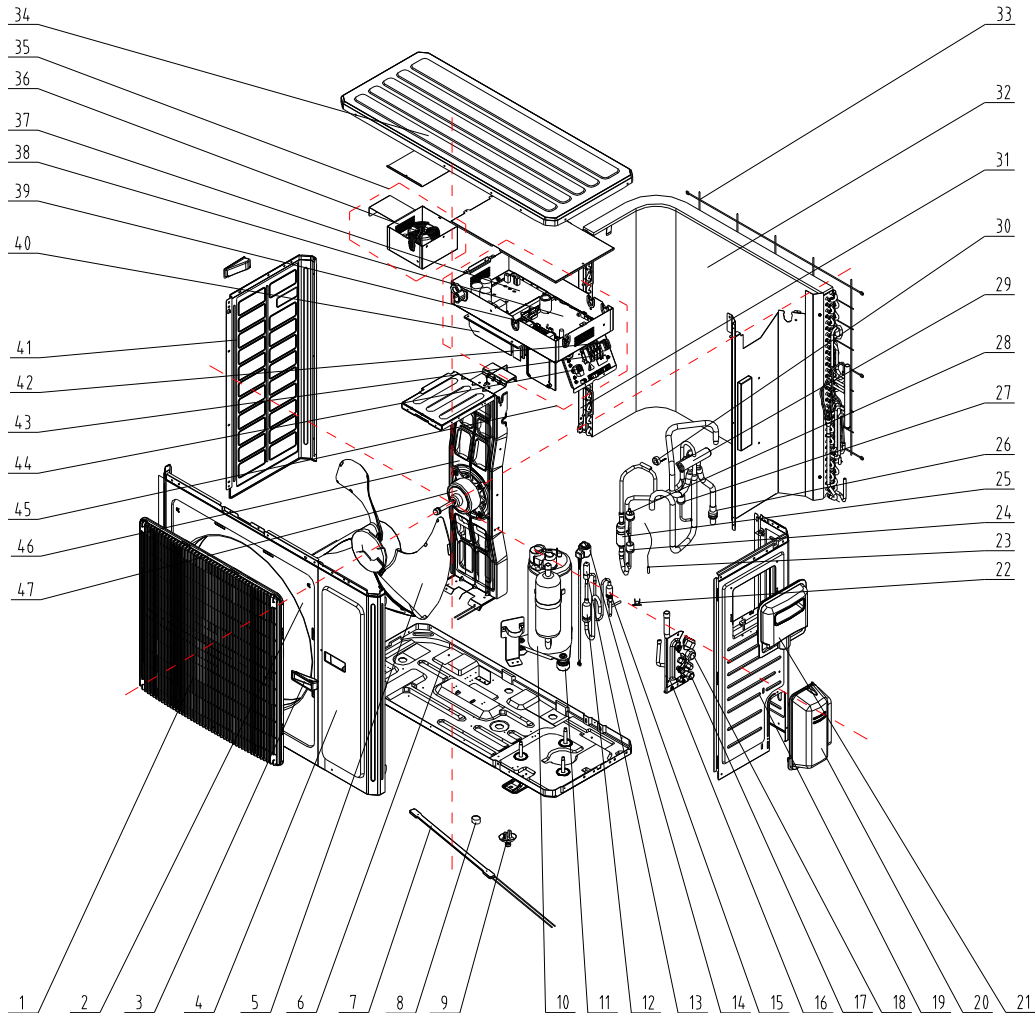

NO.	Name of Part	GUHD24NS3GO	
		Product Code	CF090W0800
		part Code	Quantity
1	Front Grill	'22415003	1
2	Cabinet	'01435004P	1
3	Left Handle	'26235401	2
4	Front Side Plate	'01305086P	1
5	Axial Flow Fan	'10335014	1
6	Chassis Sub-Assy	'0119520001301P	1
7	Electrical Heater(Compressor)	'7651873209	1
8	Drainage Hole Cap	'06813401	3
9	Drainage Connector	'06123401	1
10	Compressor and Fittings	'0010505701	1

11	Compressor Gasket	'76713066	3
12	Bidirection Strainer	'07220016	1
13	Electronic Expansion Valve	'07334447	1
14	Electric Expand Valve Fitting	'4304413208	1
15	Strainer	'07225088	1
16	Valve Support Sub-Assy	'0171501201P	1
17	Valve	'07100005	1
18	Cut off Valve	'07133157	1
19	Right Side Plate Sub-Assy	'01315200069P	1
20	Valve Cover	'22245003	1
21	Big Handle	'26235001	1
22	Compressor Overload Protector(External)	00180030& '00183051& '00183032& '00183031	1
23	Temperature Sensor	'3900028020G	1
24	Pressure Protect Switch	'4602000902	1
25	Silencer	'07245012	1
26	Strainer	'07215201	1
27	Pressure Protect Switch	'4602001510	1
28	Pressure Protect Switch	'46020003	1
29	4-way Valve	'4300008201	1
30	Magnet Coil	'4300040045	1
31	Condenser Support Plate	'01175092	1
32	Condenser Assy	'01125200184	1
33	Rear Grill	'01475013	1
34	Top Cover Sub-Assy	'01255007	1
35	Inductance Box Sub-Assy	'01395200176	1
36	PFC Inductance	'43128003	1
37	Main Board	'30221000010	1
38	Main Board	'30224000066	1
39	Filter Board	'30221000007	1
40	Radiator	'49018000042	1
41	Left Side Plate	'01305043P	1
42	Terminal Board	'420101852	1
43	Terminal Board	'42010274	1
44	Socket	'42030033	1
45	Electric Box Assy	'01395200437	1
46	Motor Support Assy	'01805200166	1
47	Fan Motor	'15702802	1

Above data is subject to change without notice, pls reference the SP in global service website.



◆ Model: GUHD36NS3GO Exploded Views and spare parts list:

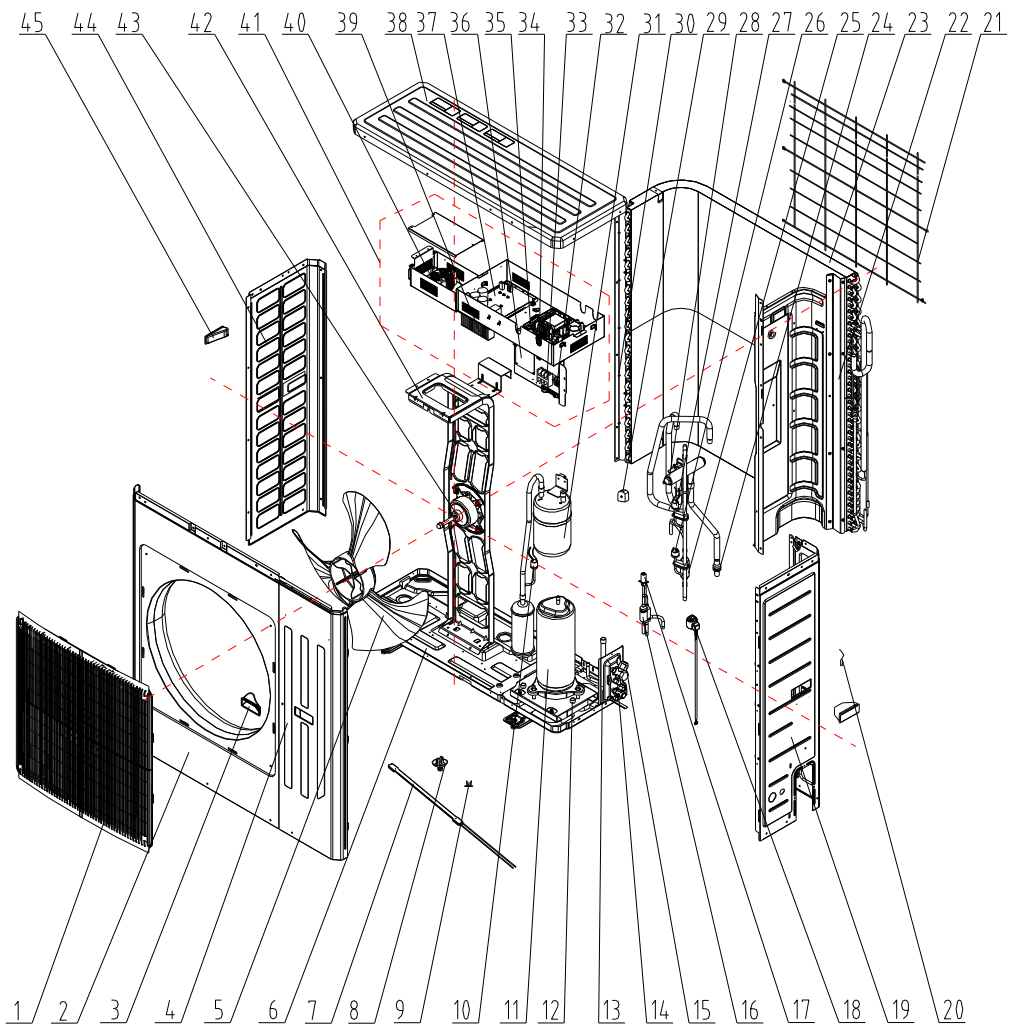

NO.	Name of Part	GUHD36NS3GO	
		Product Code	CF090W0860
		part Code	Quantity
1	Front Grill	'22415005	1
2	Cabinet	'01435007P	1
3	Handle	'26235253	2
4	Front Side Plate Sub-Assy	'01305508	1
5	Axial Flow Fan	'10335010	1
6	Chassis Sub-assy	'01195244P	1
7	Electrical Heater(Compressor)	'7651873209	1
8	Drainage Joint	'26113009	1
9	Compressor Overload Protector(External)	00180030\ 00183051\ 00183032\ 00183031	1
10	Pressure Protect Switch	'4602001539	1
11	Compressor	'00205200003	1
12	Compressor Gasket	'76713066	3
13	Valve Support Sub-Assy	'01805200222P	1

14	Cut off Valve	'071302391	1
15	Cut off Valve	'07133157	1
16	Strainer	'0741410000601	2
17	Electronic Expansion Valve	'07135176	1
18	Electric Expand Valve Fitting	'43000344	1
19	Right Side Plate Sub-Assy	'01315200068P	1
20	Temperature Sensor	'39008000049G	1
21	Rear Grill	'01475012	1
22	Clapboard Sub-Assy	'0124525303	1
23	Condenser Assy	'01125200269	1
24	Strainer	'07215201	1
25	Silencer	'07245012	1
26	Pressure Protect Switch	'46020003	1
27	Pressure Protect Switch	'4602000902	1
28	4-way Valve	'43000338	1
29	Magnet Coil	'4300040045	1
30	Condenser Support Plate	'01795020	1
31	Gas-liquid Separator Sub-Assy	'07255201	1
32	Terminal Board	'420101852	1
33	Terminal Board	'42010267	1
34	Filter Board	'30221000007	1
35	Main Board	'30224000066	1
36	Communication Interface Board	'30111021	1
37	Main Board	'30221000003	1
38	Top Cover	'0125500901P	1
39	Radiator	'49018000047	1
40	PFC Inductance	'43120011	1
41	Electric Box Assy	'01395200494	1
42	Motor Support Sub-Assy	'01805200212	1
43	Fan Motor	'1570280201	1
44	Left Side Plate	'01305064P	1
45	Left Handle	'26235401	1

Above data is subject to change without notice, pls reference the SP in global service website.

◆ Model: GUHD42NS3GO Exploded Views and spare parts list:

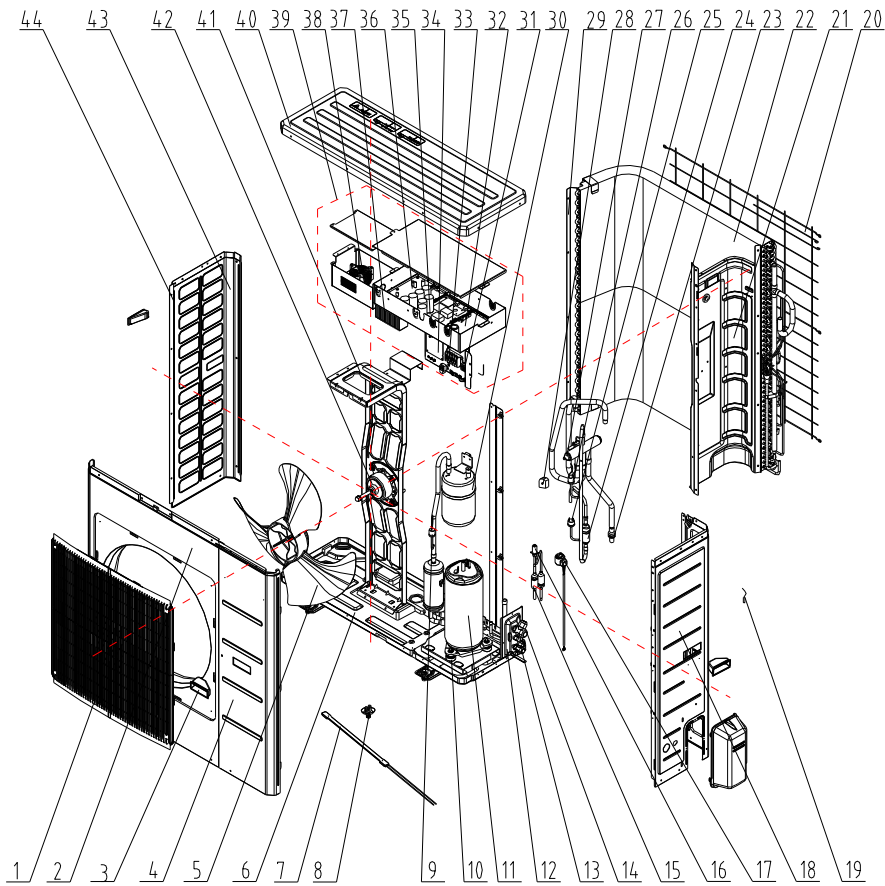

NO.	Name of Part	GUHD42NS3GO	
		Product Code	CF090W0870
		part Code	Quantity
1	Front Grill	'22415005	1
2	Cabinet	'01435007P	1
3	Handle	'26235253	2
4	Front Side Plate Sub-Assy	'01305508	1
5	Axial Flow Fan	'10335010	1
6	Chassis Sub-assy	'01195244P	1
7	electrical heater	'765152123	1
8	Drainage Joint	'26113009	1
9	Pressure Protect Switch	'4602001539	1
10	Compressor Gasket	'76710247	3
11	Compressor	'00204100001	1
12	Valve Support Sub-Assy	'01805200222P	1
13	Cut off Valve	'071302391	1
14	Cut off Valve	'07133157	1
15	Strainer	'0741410000601	2

16	Electronic Expansion Valve	'07135176	1
17	Electric Expand Valve Fitting	'43000344	1
18	Right Side Plate Sub-Assy	'01315200068P	1
19	Temperature Sensor	'39008000049G	1
20	Rear Grill	'01475012	1
21	Clapboard Sub-Assy	'0124525303	1
22	Condenser Assy	'01125200196	1
23	Strainer	'07215201	1
24	Silencer	'07245012	1
25	Pressure Protect Switch	'46020003	1
26	Pressure Protect Switch	'4602000902	1
27	4-way Valve	'43000338	1
28	Magnet Coil	'4300040045	1
29	Condenser support plate	'01895242	1
30	Gas-liquid Separator Sub-Assy	'07255201	1
31	Terminal Board	'420101852	1
32	Main Board	'30224000066	1
33	Terminal Board	'4201025801	1
34	Communication Interface Board	'30111021	1
35	Filter Board	'30228000006	1
36	Main Board	'30228000005	1
37	Radiator	'49018000052	1
38	PFC Inductance	'43128000015	1
39	Electric Box Assy	'01395200495	1
40	Top Cover	'0125500901P	1
41	Motor Support Sub-Assy	'01805200190	1
42	Fan Motor	'1570280201	1
43	Left Side Plate	'01305064P	1
44	Left Handle	'26235401	1

Above data is subject to change without notice, pls reference the SP in global service website.

◆ Model: GUHD48NS3GO Exploded Views and spare parts list:

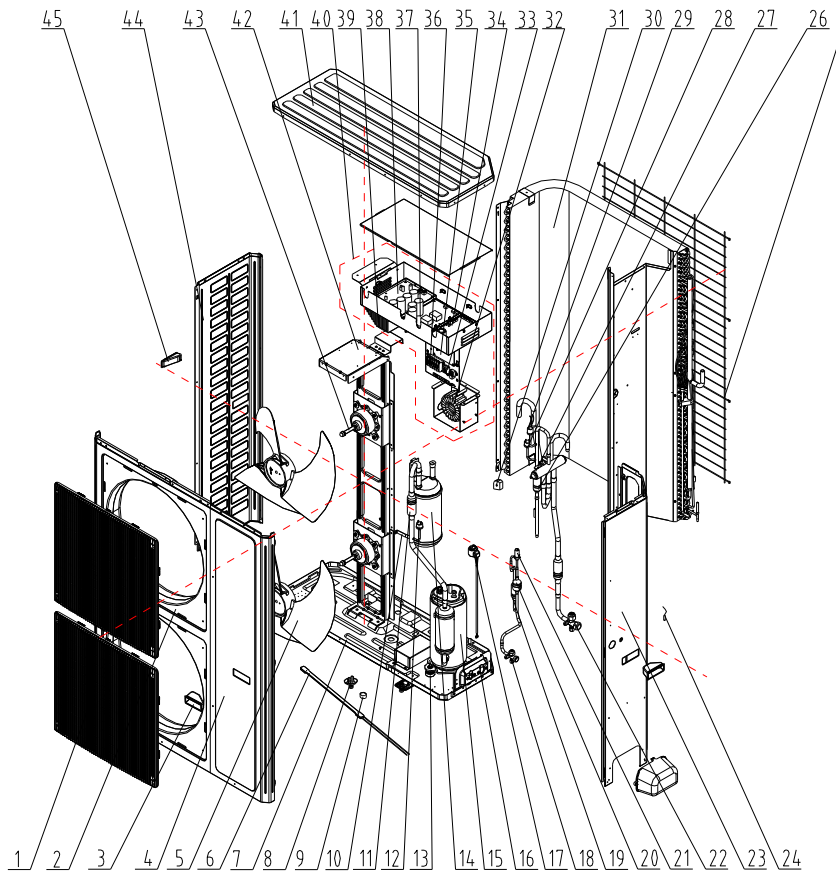

NO.	Name of Part	GUHD48NS3GO	
		Product Code	CF090W0880
		part Code	Quantity
1	Front Grill	'22415002	2
2	Cabinet	'01515204P	1
3	Handle	'26235253	2
4	Front Side Plate	'01315364P	1
5	Axial Flow Fan	'10335008	2
6	electrical heater	'765152123	1
7	Chassis Sub-assy	'01195200030P	1
8	Drainage Connector	'06123401	1
9	Drainage hole Cap	'06813401	3
10	Liquid Accumulator Clamp	'02145435	1
11	Strainer	'07210037	2
12	Pressure Protect Switch	'46020007	1
13	Compressor Gasket	'76710247	3
14	Gas-liquid Separator Sub-Assy	'0722501801	1
15	Compressor	'00204100001	1
16	Valve Support Sub-Assy	'0171500101	1
17	Electric Expand Valve Fitting	'43000344	1

18	Cut off Valve	'07130209	1
19	Bidirection Strainer	'07220016	1
20	Strainer	'07415210	2
21	Electronic Expansion Valve	'07135176	1
22	Cut off Valve	'07103030	1
23	Rear Side Plate Sub-Assy	'01315462P	1
24	Temperature Sensor	'3900028025G	1
25	Rear Grill	'01575205	1
26	Silencer	'07245012	1
27	4-way Valve	'43000338	1
28	Pressure Protect Switch	'46020003	1
29	Pressure Protect Switch	'4602000902	1
30	Magnet Coil	'4300040032	1
31	Condenser Assy	'01025396	1
32	Inductance	'43120122	1
33	Terminal Board	'420101852	1
34	Main Board	'30224000066	1
35	Communication Interface Board	'30111021	1
36	Terminal Board	'4201025801	1
37	Filter Board	'30228000006	1
38	Main Board	'30228000005	1
39	Radiator	'49018000084	1
40	Electric Box Assy	'01395200442	1
41	Top Cover	'01265356P	1
42	Motor Support Assy	'01805200247	1
43	Fan Motor	'1570280203	2
44	Left Side Plate	'01315366P	1
45	Left Handle	'26235401	1

Above data is subject to change without notice,pls reference the SP in global service website.

◆ Model: GUHD60NS3GO Exploded Views and spare parts list:

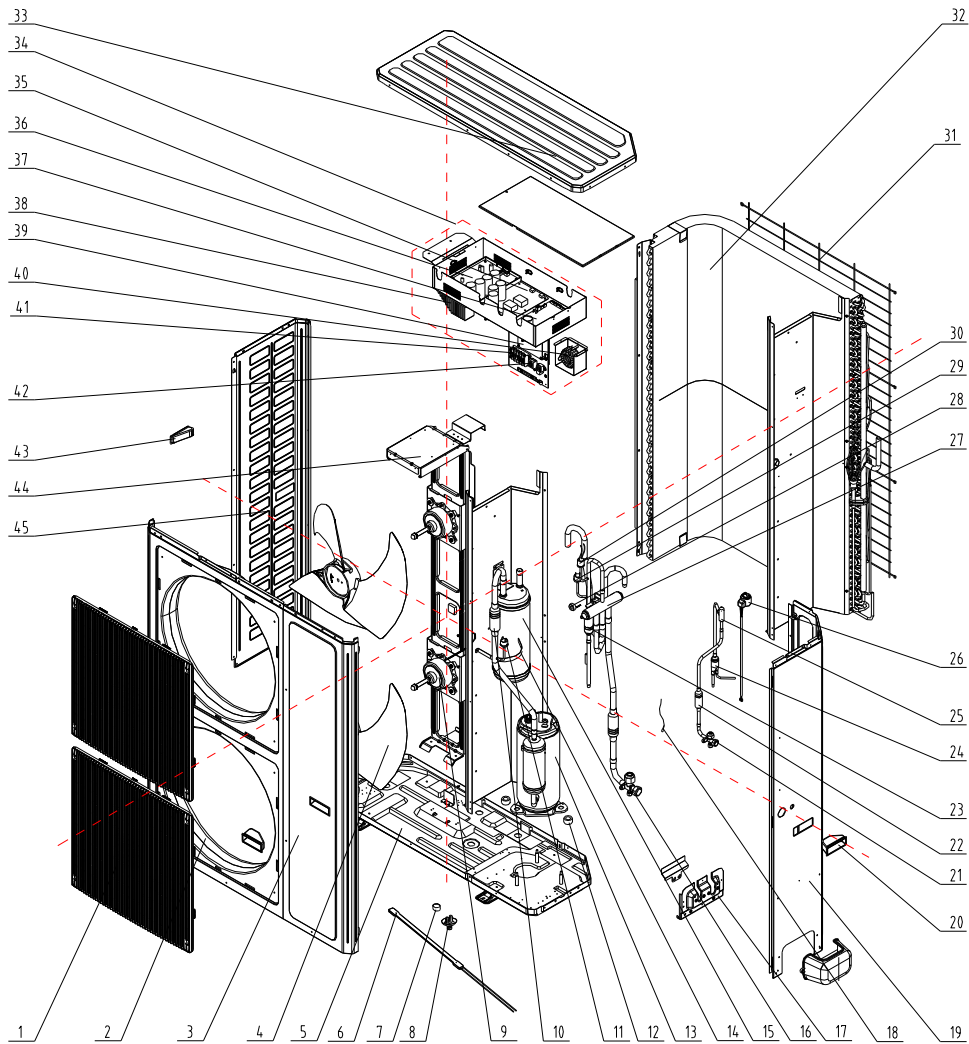

NO.	Name of Part	GUHD60NS3GO	
		part Code	Quantity
		part Code	Quantity
1	Front Grill	'22415002	2
2	Cabinet	'01515204P	1
3	Front Side Plate	'01315364P	1
4	Axial Flow Fan	'10335008	2
5	Chassis Sub-Assy	'01195200030P	1
6	Electrical Heater	'765152123	1
7	Drainage hole Cap	'06813401	3
8	Drainage Connector	'06123401	1
9	Fan Motor	'1570280203	2
10	Strainer	'07210037	2
11	Pressure Protect Switch	'46020007	1
12	Compressor Gasket	'76710247	3
13	Compressor	'00204100001	1

14	Liquid Accumulator Clamp	'02145435	1
15	Gas-liquid Separator	'07225016	1
16	Cut-off Valve	'07130212	1
17	Valve Support Sub-Assy	'0171500101	1
18	Temperature Sensor	'3900028025G	1
19	Rear Side Plate Sub-Assy	'01315462P	1
20	Handle	'26235253	2
21	Cut off Valve	'07130209	1
22	Bidirection Strainer	'07220016	1
23	Silencer	'07245012	1
24	Strainer	'07210045	1
25	Electronic Expansion Valve	'07334412	1
26	Electric Expand Valve Fitting	'4304413207	1
27	4-way Valve	'43000338	1
28	Magnet Coil	'4300040032	1
29	Pressure Protect Switch	'46020003	1
30	Pressure Protect Switch	'4602000902	1
31	Rear Grill	'01575205	1
32	Condenser Assy	'01125200251	1
33	Top Cover	'01265356P	1
34	Electric Box Assy	'01395200442	1
35	Filter Board	` 30228000006	1
36	Main Board	` 30228000005	1
37	Main Board	` 30224000066	1
38	Radiator	` 49018000084	1
39	Communication Interface Board	` 30111021	1
40	Inductance	` 43120122	1
41	Terminal Board	` 4201025801	1
42	Terminal Board	` 420101852	1
43	Left Handle	'26235401	1
44	Motor Support Assy	'01805200247	1
45	Left Side Plate	'01315366P	1

Above data is subject to change without notice, pls reference the SP in global service website.



## 5.2 Indoor Unit

### 5.2.1 Duct Type

◆ Model: GFH24S3GI exploded view and spare parts list

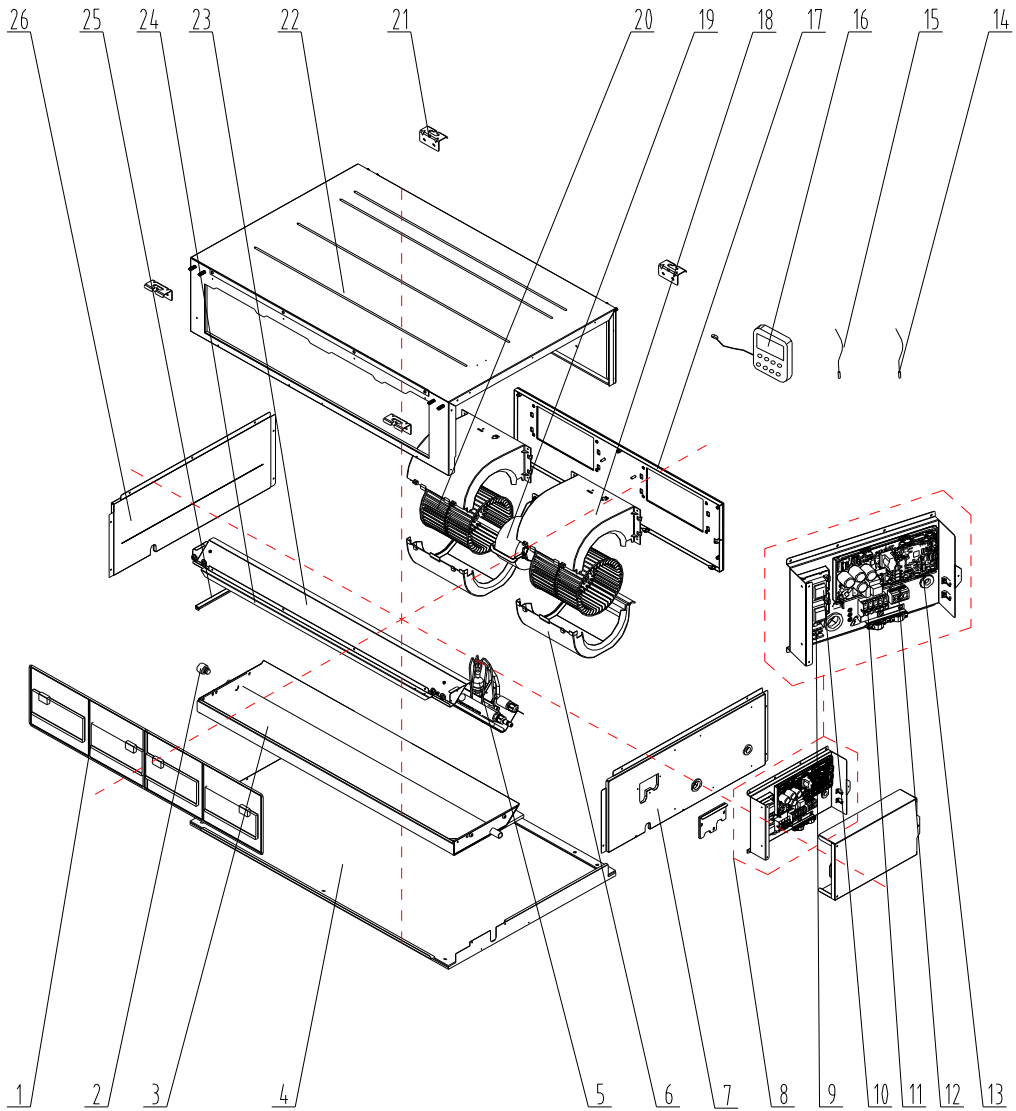

NO.	Name of Part	GFH24S3GI	
		Product Code	CF060N0560
		part Code	Quantity
1	Filter Sub-Assy	'111253031	2
2	Choke Plug of Drain Pipe	'76712455	2
3	Water Tray Assy	'01285323	1
4	Lower Cover Plate Sub-Assy	'15265301	1
5	Strainer	'07415210	1
6	Propeller Housing(Lower)	'26904100052	2
7	Right Side Plate Sub-Assy	'0131520015501	1
8	Electric Box Assy	'01395200470	1
9	Terminal Board	'42011149	1
10	Filter Board	'30226000065	2
11	Terminal Board	'42010194	1
12	Terminal Board	'4201025301	1
13	Main Board	'30224000065	1
14	Temperature Sensor	'390001921G	1
15	Ambient Temperature Sensor	'3900012123	1
16	Display Board	'30294000007	1
17	Blower Mounting Plate Sub-Assy	'01325200044	1
18	Propeller Housing(Upper)	'26904100051	2
19	Brushless DC Motor	'1570940000601	1
20	Centrifugal Fan	'10424100001	2
21	Hook	'02112466	4
22	Top Cover Board Assy	'01265200086	1
23	Evaporator Assy	'01025200120	1
24	Side Plate of Air intake	'01375301	1
25	Supporting Board of evaporator	'018953022	1
26	Left Side Plate Assy	'01315306	1

Above data is subject to change without notice, pls reference the SP in global service website.

◆ Model: GFH24S3G1I exploded view and spare parts list

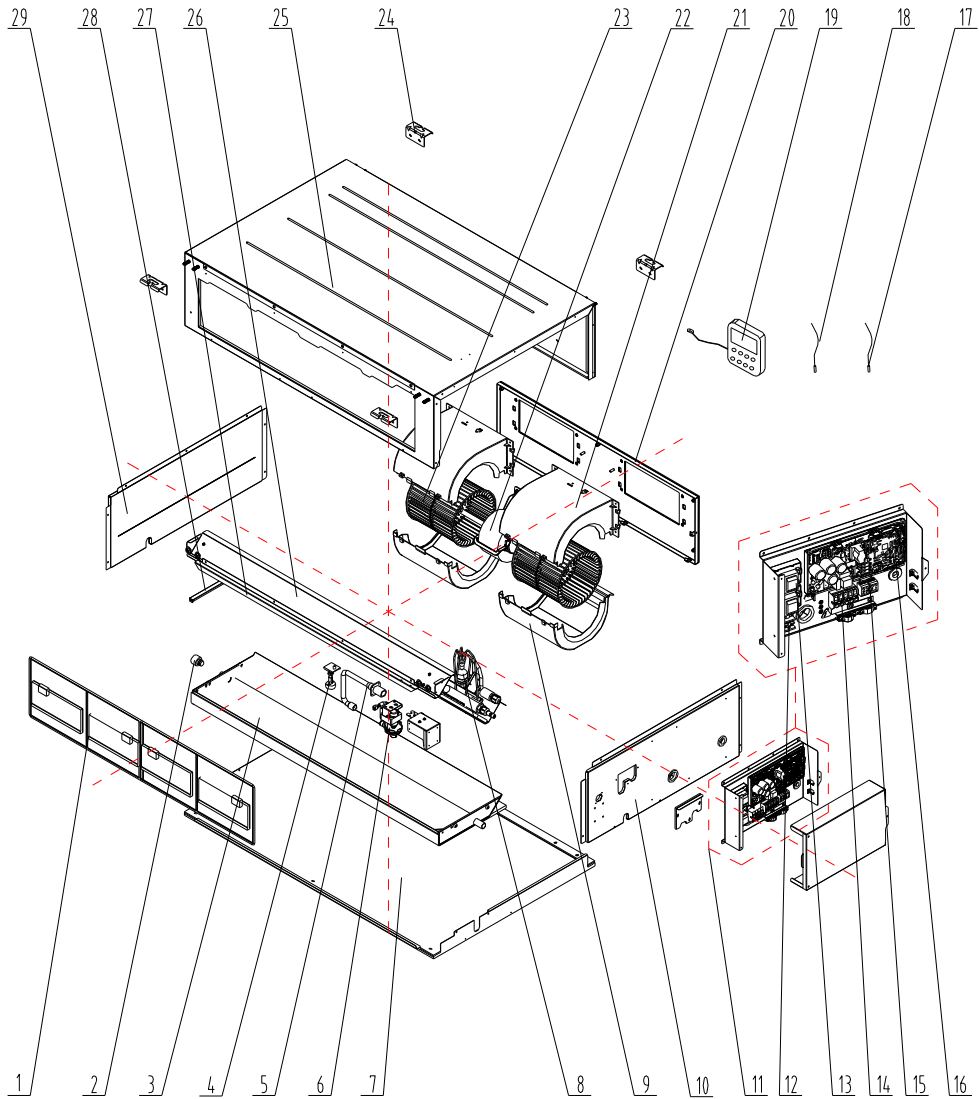

NO.	Name of Part	GFH24S3G1I	
		Product Code	CF060N0561
		part Code	Quantity
1	Filter Sub-Assy	'111253031	2
2	Choke Plug of Drain Pipe	'76712455	2
3	Water Tray Assy	'01285323	1
4	Liquid Level Switch	'4501801203	1
5	Pump Drainpipe	'05235301	1
6	Water Pump	'43138220	1
7	Lower Cover Plate Sub-Assy	'15265301	1
8	Strainer	'07415210	1
9	Propeller Housing(Lower)	'26904100052	2
10	Right Side Plate Sub-Assy	'01315200155	1
11	Electric Box Assy	'01395200470	1
12	Terminal Board	'42011149	1
13	Filter Board	'30226000065	2
14	Terminal Board	'42010194	1
15	Terminal Board	'4201025301	1
16	Main Board	'30224000065	1
17	Temperature Sensor	'390001921G	1
18	Ambient Temperature Sensor	'3900012123	1
19	Display Board	'30294000007	1
20	Blower Mounting Plate Sub-Assy	'01325200044	1
21	Propeller Housing(Upper)	'26904100051	2
22	Brushless DC Motor	'1570940000601	1
23	Centrifugal Fan	'10424100001	2
24	Hook	'02112466	4
25	Top Cover Board Assy	'01265200086	1
26	Evaporator Assy	'01025200120	1
27	Side Plate of Air intake	'01375301	1
28	Supporting Board of evaporator	'018953022	1
29	Left Side Plate Assy	'01315306	1

Above data is subject to change without notice, pls reference the SP in global service website.

◆ Model: GFH36S3GI exploded view and spare parts list

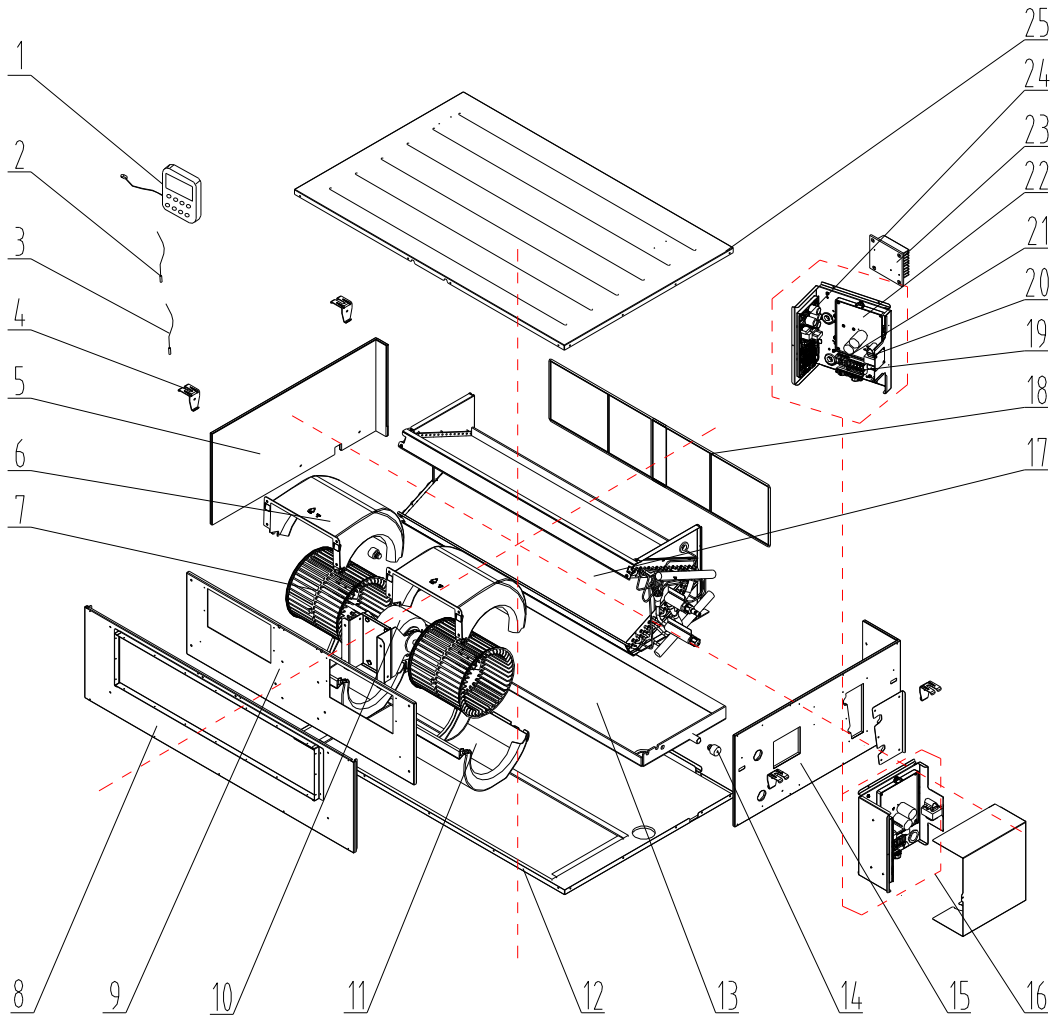

NO.	Name of Part	GFH36S3GI	
		Product Code	CF060N0650
		part Code	Quantity
1	Display Board	'30294000007	1
2	Ambient Temperature Sensor	'3900012123	1
3	Tube sensor	'3900012128	1
4	Hook	'02205209	4
5	Left Side Plate Sub-Assy	'01315200064	1
6	Propeller Housing(Upper)	'26905200010	2
7	Centrifugal Fan	'10425200002	2
8	Front Side Plate Sub-Assy	'01315200091	1
9	Blower Mounting Plate Sub-Assy	'01325200057	1
10	Brushless DC Motor	'15709400008	1
11	Propeller Housing(Lower)	'26905200011	2
12	Top Cover Board Assy	'01265200045	1
13	Water Tray Assy	'01285200025	1
14	Choke Plug of Drain Pipe	'76712455	2
15	Right Side Plate Assy	'01315200161	1
16	Electric Box Assy	'01395200458	1
17	Water Pump	'4313822001	1
18	Water Level Switch	'4501270301	1
19	Pump Drainpipe	'05235301	1
20	Evaporator Assy	'01025200133	1
21	Filter Sub-Assy	'111253036	2
22	Terminal Board	'42010194	1
23	Reactor	'43138000047	1
24	Terminal Board	'4201025301	1
25	Main Board	'30221000018	1
26	Radiator	'49018000068	1
27	Main Board	'30224000063	1
28	Bottom Cover Plate Assy	'01265200081	1

Above data is subject to change without notice, pls reference the SP in global service website.

◆ Model: GFH36S3G1I exploded view and spare parts list

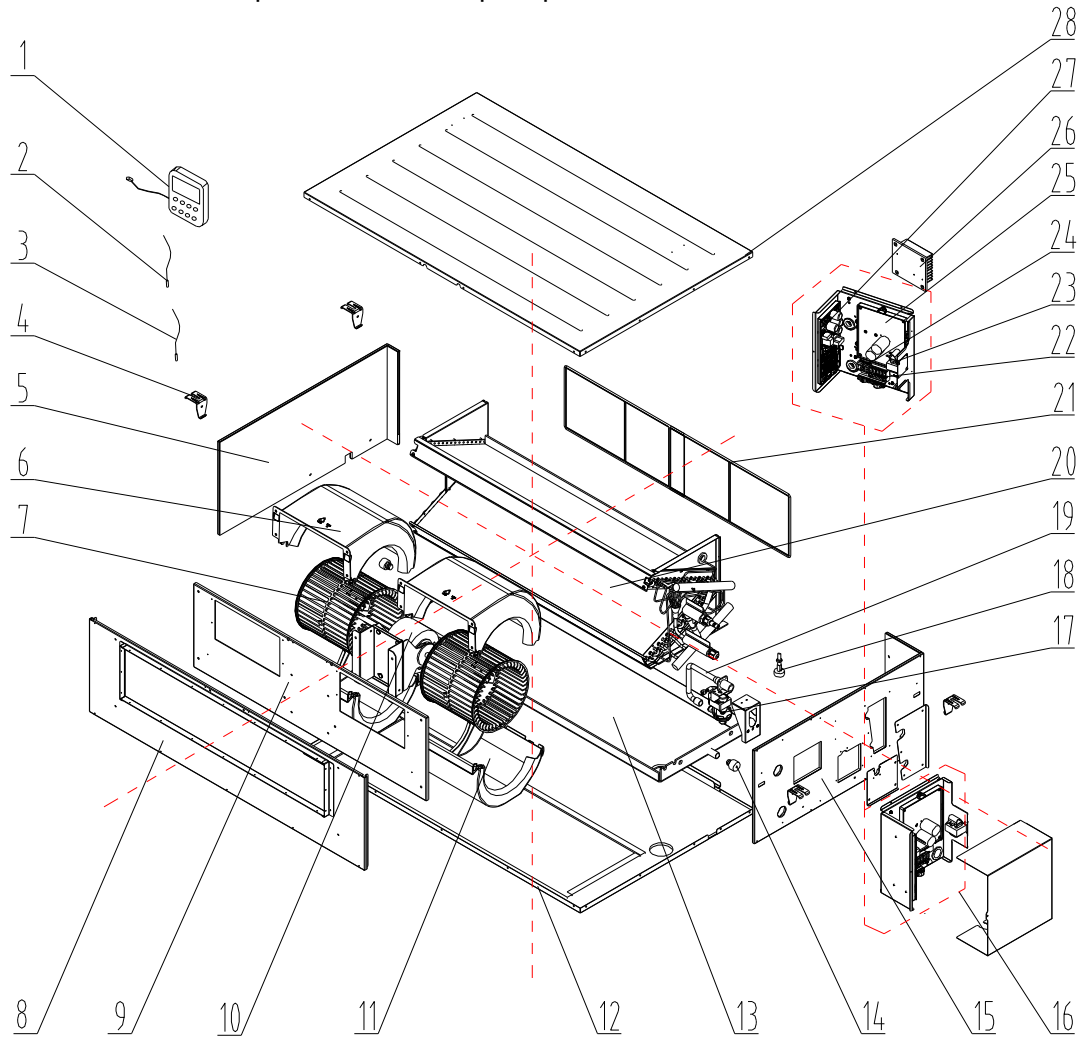

NO.	Name of Part	GFH36S3G11	
		Product Code	CF060N0660
		part Code	Quantity
1	Display Board	'30294000007	1
2	Ambient Temperature Sensor	'3900012123	1
3	Tube sensor	'3900012128	1
4	Hook	'02205209	4
5	Left Side Plate Sub-Assy	'01315200064	1
6	Propeller Housing(Upper)	'26905200010	2
7	Centrifugal Fan	'10425200002	2
8	Front Side Plate Sub-Assy	'01315200091	1
9	Blower Mounting Plate Sub-Assy	'01325200057	1
10	Brushless DC Motor	'15709400008	1
11	Propeller Housing(Lower)	'26905200011	2
12	Top Cover Board Assy	'01265200045	1
13	Water Tray Assy	'01285200025	1
14	Choke Plug of Drain Pipe	'76712455	2
15	Right Side Plate Assy	'01315200161	1
16	Electric Box Assy	'01395200458	1
17	Water Pump	'4313822001	1
18	Water Level Switch	'4501270301	1
19	Pump Drainpipe	'05235301	1
20	Evaporator Assy	'01025200133	1
21	Filter Sub-Assy	'111253036	2
22	Terminal Board	'42010194	1
23	Reactor	'43138000047	1
24	Terminal Board	'4201025301	1
25	Main Board	'30221000018	1
26	Radiator	'49018000068	1
27	Main Board	'30224000063	1
28	Bottom Cover Plate Assy	'01265200081	1

Above data is subject to change without notice, pls reference the SP in global service website.



◆ Model: GFH42S3GI/GFH48S3GI exploded view and spare parts list

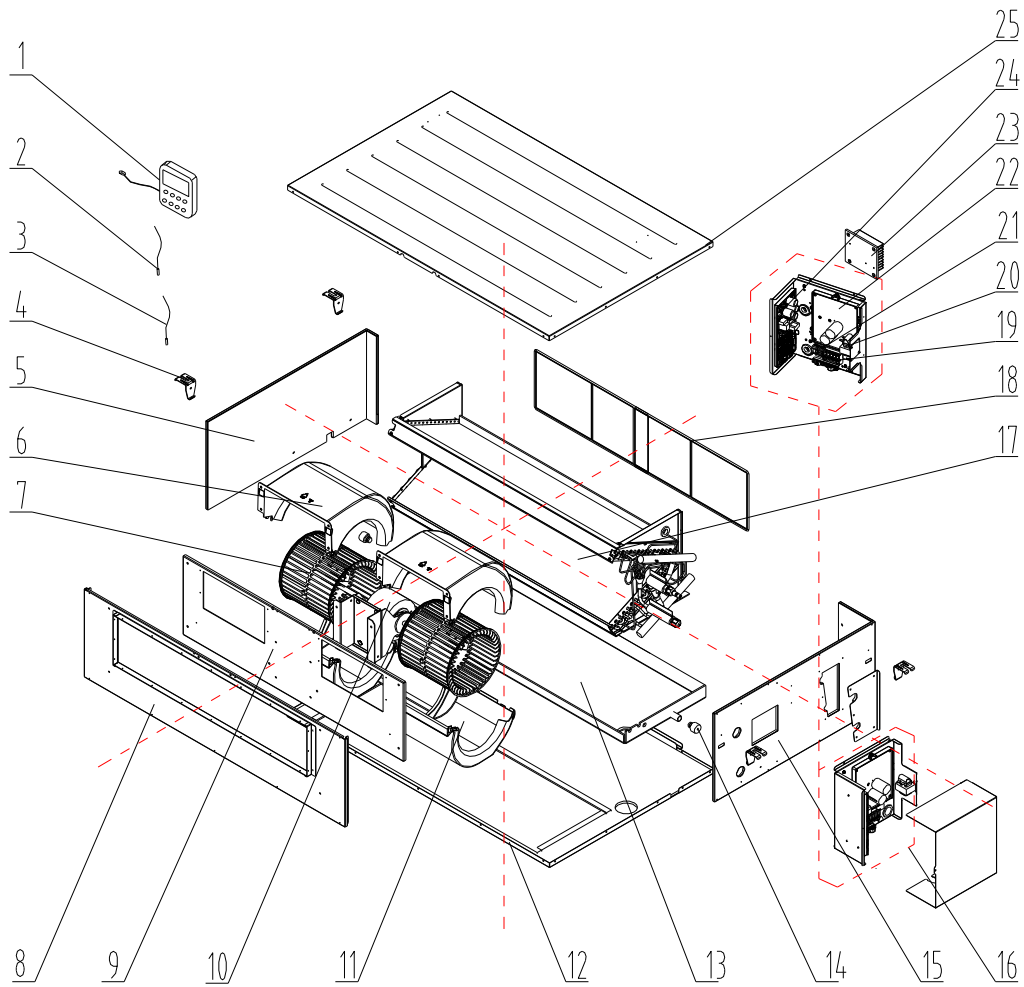

NO.	Name of Part	GFH42S3GI		GFH48S3GI	
		Product Code	CF060N0670	Product Code	CF060N0670
		part Code	Quantity	part Code	Quantity
1	Display Board	'30294000007	1	'30294000007	1
2	Ambient Temperature Sensor	'3900012123	1	'3900012123	1
3	Tube sensor	'3900012128	1	'3900012128	1
4	Hook	'02205209	4	'02205209	4
5	Left Side Plate Sub-Assy	'01315200064	1	'01315200064	1
6	Propeller Housing(Upper)	'26905200010	2	'26905200010	2
7	Centrifugal Fan	'10425200002	2	'10425200002	2
8	Front Side Plate Sub-Assy	'01315200091	1	'01315200091	1
9	Blower Mounting Plate Sub-Assy	'01325200057	1	'01325200057	1
10	Brushless DC Motor	'15709400008	1	'15709400008	1
11	Propeller Housing(Lower)	'26905200011	2	'26905200011	2
12	Top Cover Board Assy	'01265200045	1	'01265200045	1
13	Water Tray Assy	'01285200025	1	'01285200025	1
14	Choke Plug of Drain Pipe	'76712455	2	'76712455	2
15	Right Side Plate Assy	'01315200161	1	'01315200161	1
16	Electric Box Assy	'01395200458	1	'01395200458	1
17	Water Pump	'4313822001	1	'4313822001	1
18	Water Level Switch	'4501270301	1	'4501270301	1
19	Pump Drainpipe	'05235301	1	'05235301	1
20	Evaporator Assy	'01025200055	1	'01025200055	1
21	Filter Sub-Assy	'111253036	2	'111253036	2
22	Terminal Board	'42010194	1	'42010194	1
23	Reactor	'43138000047	1	'43138000047	1
24	Terminal Board	'4201025301	1	'4201025301	1
25	Main Board	'30221000018	1	'30221000018	1
26	Radiator	'49018000068	1	'49018000068	1
27	Main Board	'30224000063	1	'30224000063	1
28	Bottom Cover Plate Assy	'01265200081	1	'01265200081	1

Above data is subject to change without notice, pls reference the SP in global service website.

◆ Model: GFH42S3G11/GFH48S3G11 exploded view and spare parts list

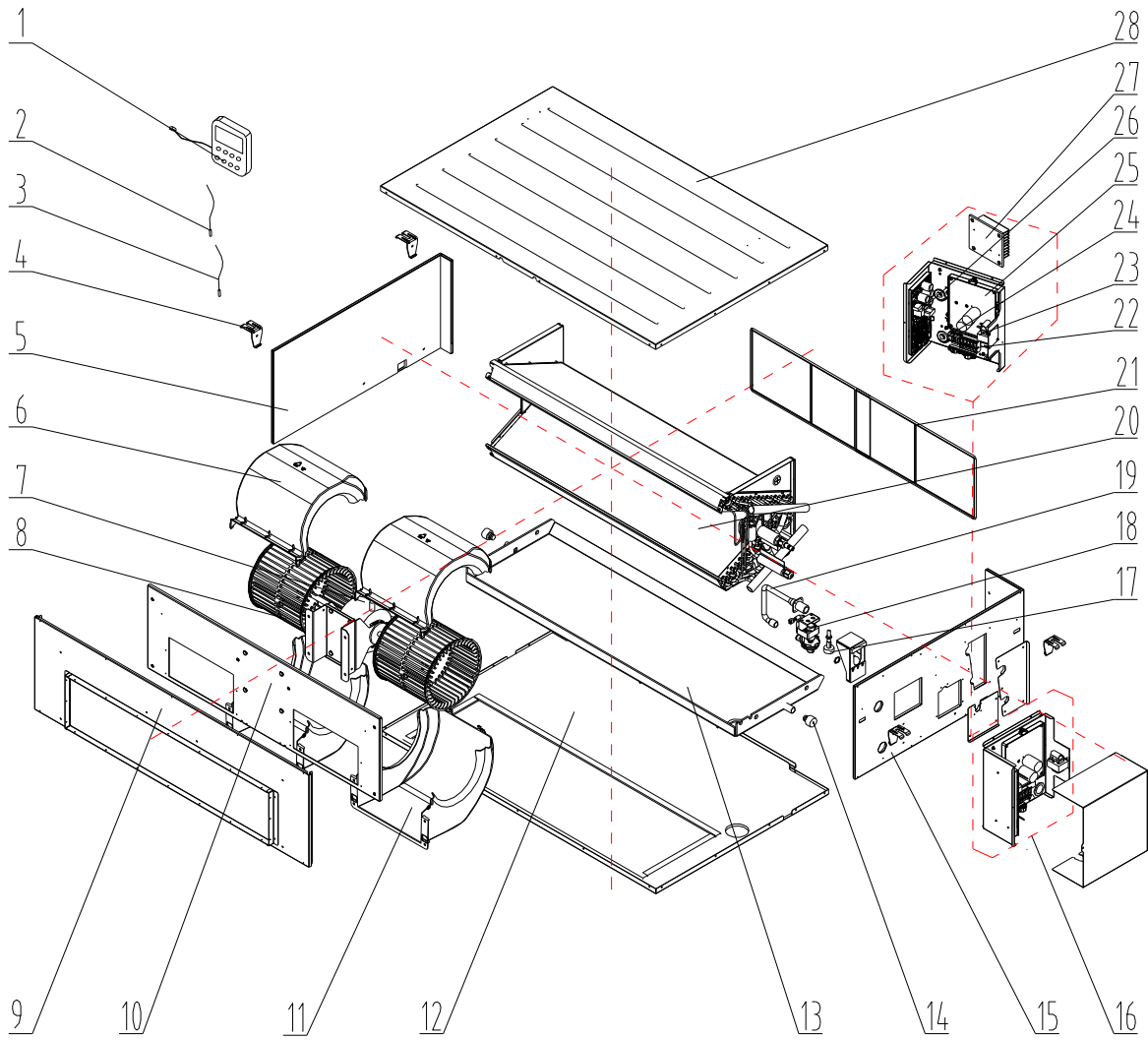

NO.	Name of Part	GFH42S3G1I		GFH48S3G1I	
		Product Code	CF060N0680	Product Code	CF060N0680
		part Code	Quantity	part Code	Quantity
1	Display Board	'30294000007	1	'30294000007	1
2	Ambient Temperature Sensor	'3900012123	1	'3900012123	1
3	Tube sensor	'3900012128	1	'3900012128	1
4	Hook	'02205209	4	'02205209	4
5	Left Side Plate Sub-Assy	'01315200064	1	'01315200064	1
6	Propeller Housing(Lower)	'26905200011	2	'26905200011	2
7	Brushless DC Motor	'15709400008	1	'15709400008	1
8	Centrifugal Fan	'10425200002	2	'10425200002	2
9	Front Side Plate Sub-Assy	'01315200091	1	'01315200091	1
10	Blower Mounting Plate Sub-Assy	'01325200057	1	'01325200057	1
11	Propeller Housing(Upper)	'26905200010	2	'26905200010	2
12	Top Cover Board Assy	'01265200045	1	'01265200045	1
13	Water Tray Assy	'01285200025	1	'01285200025	1
14	Choke Plug of Drain Pipe	'76712455	2	'76712455	2
15	Right Side Plate Assy	'01315200161	1	'01315200161	1
16	Electric Box Assy	'01395200458	1	'01395200458	1
17	Water Level Switch	'4501270301	1	'4501270301	1
18	Water Pump	'4313822001	1	'4313822001	1
19	Pump Drainpipe	'05235301	1	'05235301	1
20	Evaporator Assy	'01025200055	1	'01025200055	1
21	Filter Sub-Assy	'111253036	2	'111253036	2
22	Terminal Board	'42010194	1	'42010194	1
23	Reactor	'43138000047	1	'43138000047	1
24	Terminal Board	'4201025301	1	'4201025301	1
25	Main Board	'30221000018	1	'30221000018	1
26	Main Board	'30224000063	1	'30224000063	1
27	Radiator	'49018000068	1	'49018000068	1
28	Bottom Cover Plate Assy	'01265200081	1	'01265200081	1

Above data is subject to change without notice, pls reference the SP in global service website.

◆ Model: GFH60S3GI exploded view and spare parts list:

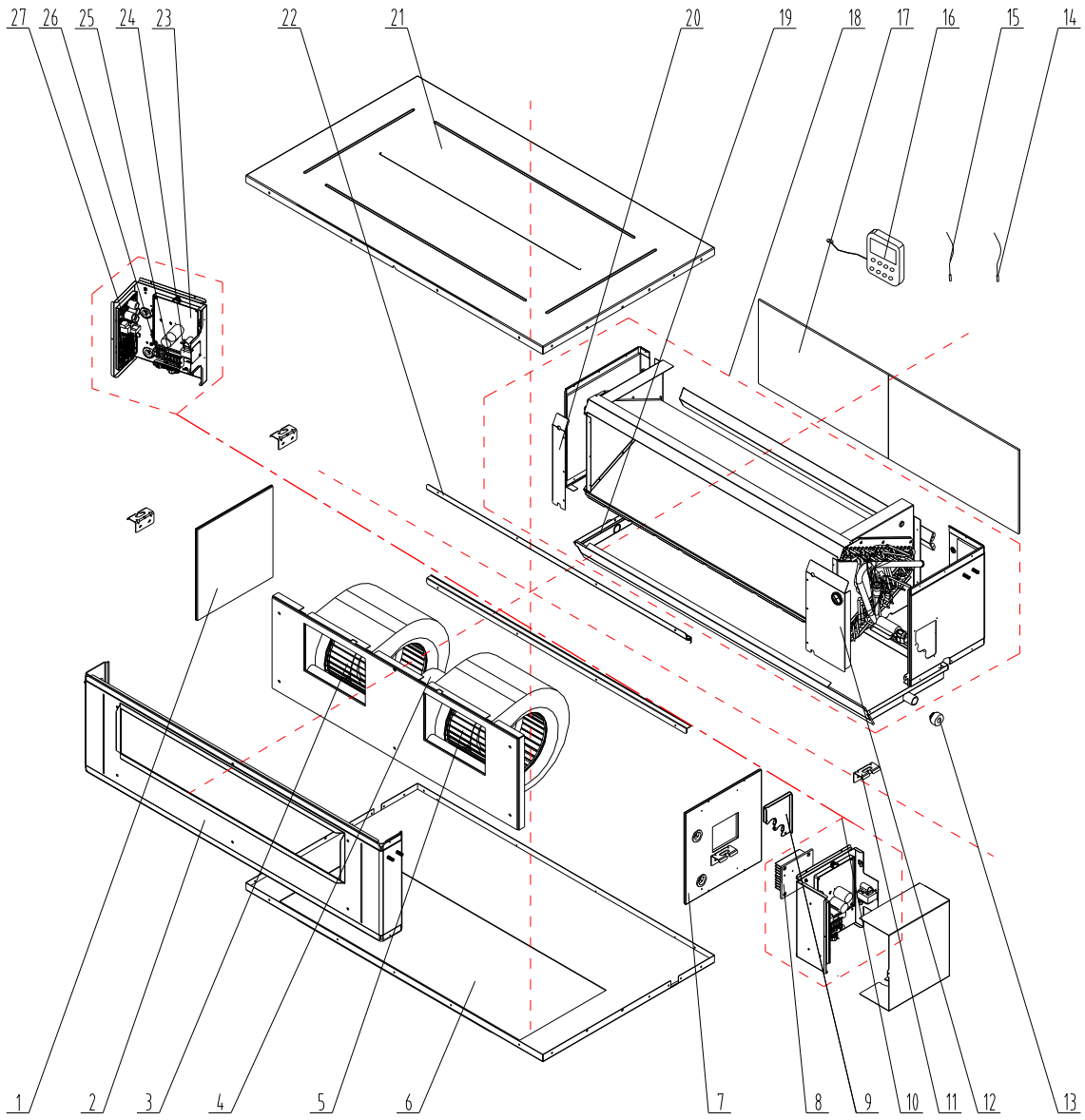

NO.	Name of Part	GFH60S3GI	
		Product Code	CF060N0550
		part Code	Quantity
1	Left Side Plate Sub-Assy	'01315376	1
2	Front Side Plate Assy	'01314627	1
3	Motor	'15705306	1
4	Brushless DC Motor	'15709400008	1
5	Motor	'15705307	1
6	Bottom Cover Plate Assy	'01265357	1
7	Right Side Plate Sub-Assy	'01315200143	1
8	Radiator	'49018000068	1
9	Seal plate Assy	'01495200051	1
10	Electric Box Assy	'01395200492	1
11	Hook	'02112466	4
12	Baffle Plate	'01355200032	1
13	Choke Plug of Water Pipe	'76712454	1
14	Tube Sensor	'3900012128	1
15	Temperature Sensor	'39000208	1
16	Display Board	'30294000007	1
17	Filter Sub-Assy	'07210029	1
18	Evaporator Assy	'01025200134	1
19	Water Tray Assy	'01285283	1
20	Baffle Plate	'01355200033	1
21	Top Cover Board Assy	'01265359	1
22	filter guide groove	'02285220	2
23	Main Board	'30221000018	1
24	Reactor	'43138000047	1
25	Terminal Board	'42010194	1
26	Terminal Board	'4201025301	1
27	Main Board	'30224000063	1

Above data is subject to change without notice,pls reference the SP in global service website.

◆ Model: GFH60S3G1I exploded view and spare parts list:

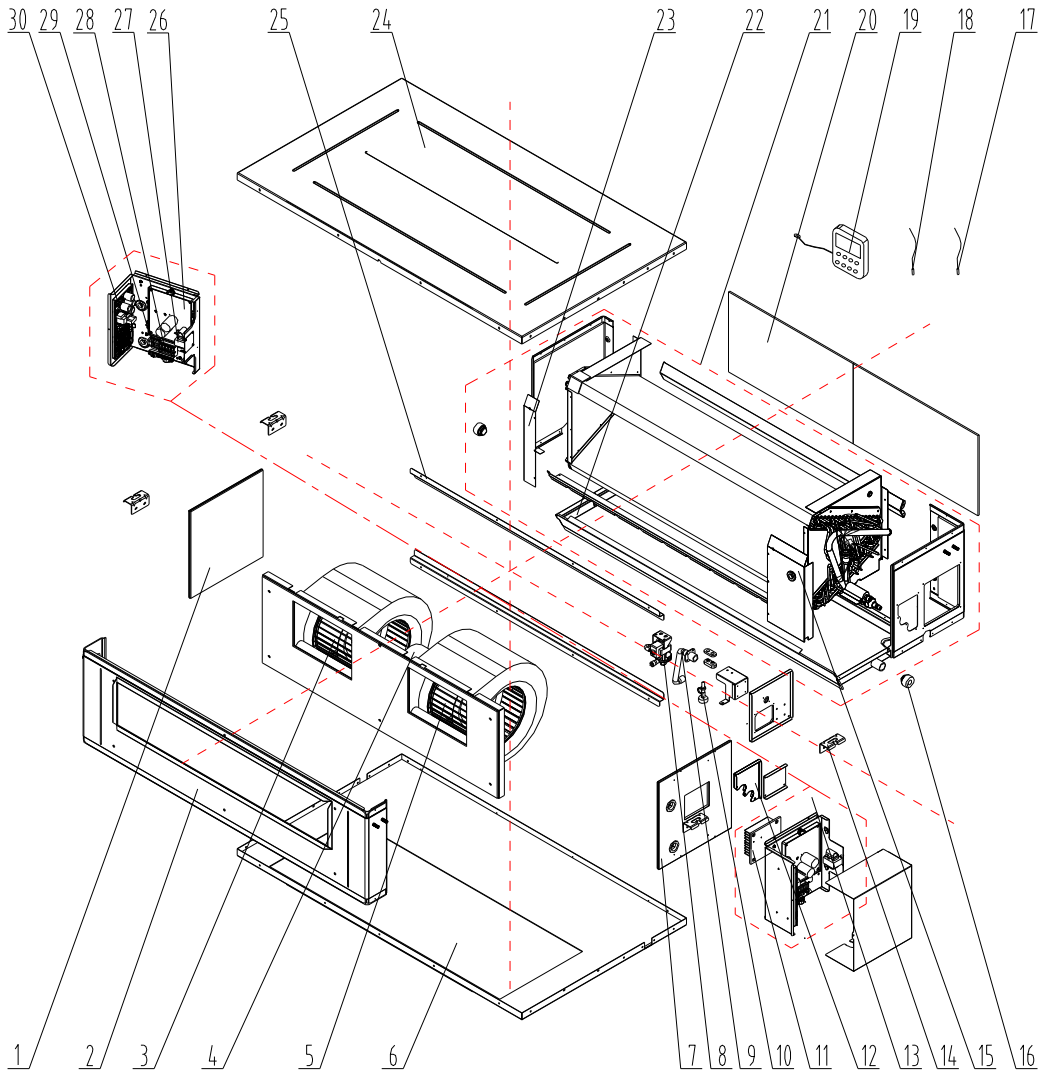

NO.	Name of Part	GFH60S3G1I	
		Product Code	CF060N0551
		part Code	Quantity
1	Left Side Plate Sub-Assy	'01315376	1
2	Front Side Plate Assy	'01314627	1
3	Motor	'15705306	1
4	Brushless DC Motor	'15709400008	1
5	Motor	'15705307	1
6	Bottom Cover Plate Assy	'01265357	1
7	Right Side Plate Sub-Assy	'01315200143	1
8	Water Pump	'43138220	1
9	Pump Drainpipe	'04615487	1
10	Water Level Switch	'4501270301	1
11	Radiator	'49018000068	1
12	Seal plate Assy	'01495200051	1
13	Electric Box Assy	'01395200458	1
14	Hook	'02112466	4
15	Baffle Plate	'01355200032	1
16	Choke Plug of Water Pipe	'76712454	2
17	Tube sensor	'3900012128	1
18	Temperature Sensor	'39000208	1
19	Display Board	'30294000007	1
20	Filter Sub-Assy	'11725211	2
21	Evaporator Assy	'01025404	1
22	Water Tray Assy	'01285283	1
23	Baffle Plate	'01355200033	1
24	Top Cover Board Assy	'01265359	1
25	filter guide groove	'02285220	2
26	Main Board	'30221000018	1
27	Reactor	'43138000047	1
28	Terminal Board	'42010194	1
29	Terminal Board	'4201025301	1
30	Main Board	'30224000063	1

Above data is subject to change without notice, pls reference the SP in global service website.



## 5.2.2 Cassette Type

◆ Model: GKH24S3GI/GKH36S3GI/GKH42S3GI exploded view and spare parts list.

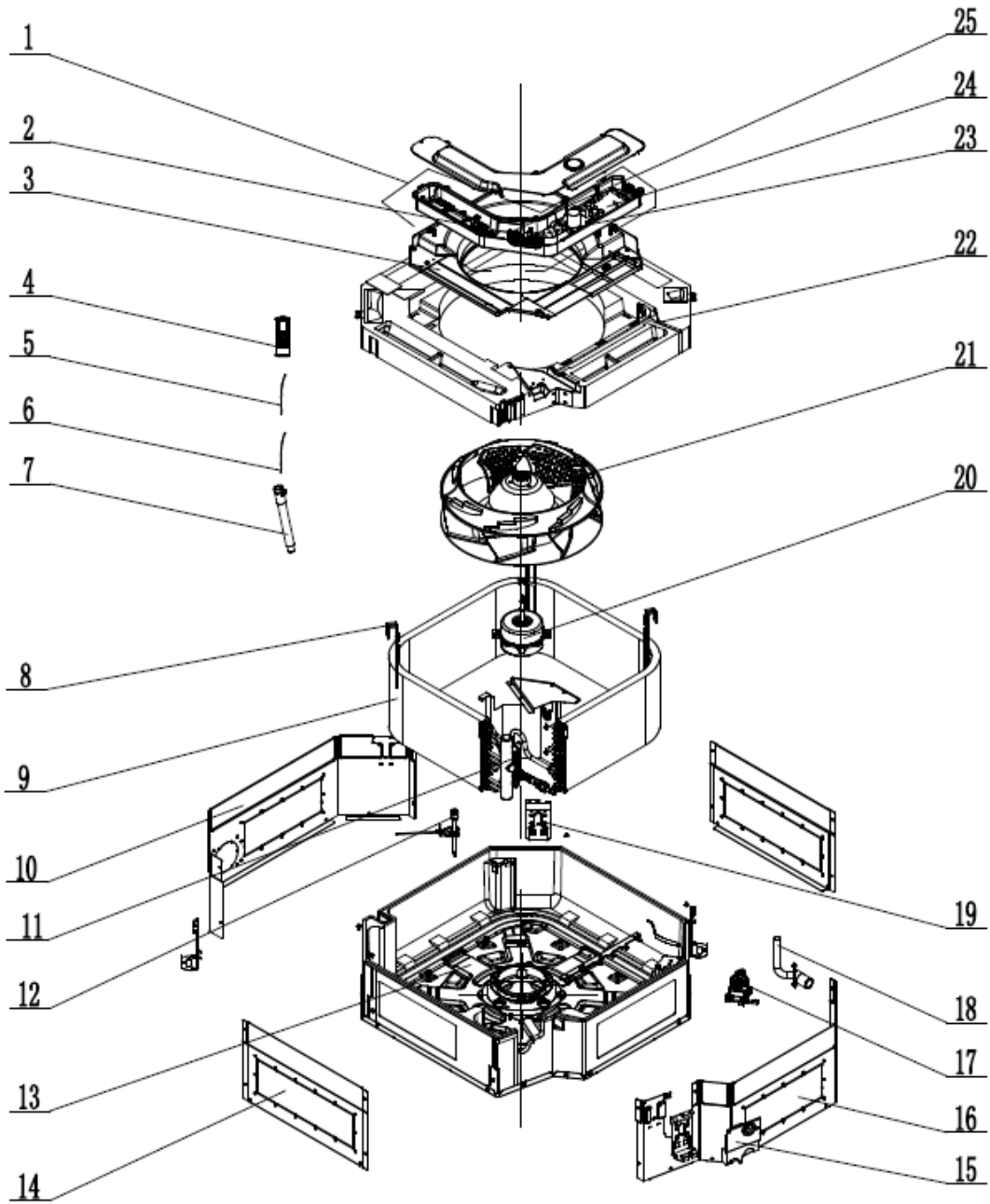

NO.	Name of Part	GKH24S3GI/GKH36S3GI/GKH42S3GI	
		Product Code	ET010N1160\ET010N1150\ET010N1170
		part Code	Quantity
1	Electric Box Assy	100002000122	1
2	Terminal Board	42010259	1
3	Diversion Circle	26909400067	1
4	Remote Controller	30510516	1
5	Tube Sensor	39000286	1
6	Temperature Sensor	390000453	1
7	Drain Hose Sub-Assy	5232702	1
8	Fixed Mount 1(Evaporator)	01849400020	3
9	Evaporator Assy	011001000115	1
10	Side Plate 1	01319400049	1
11	Strainer	07213050	1
12	Liquid Level Switch	4502021601	1
13	Base Plate Assy	02229400011	1
14	Side Plate 3	01319400051	1
15	Seal Plate Assy	01499400003	1
16	Side Plate 2	01319400050	1
17	Water Pump	43138000058	1
18	Drainage Pipe Sub-Assy	26909400055	1
19	Body installing Plate	01332701	4
20	Brushless DC Motor	1570410000701	1
21	Centrifugal Fan	10429400004	1
22	Water Tray Assy	01289400025	1
23	Filter Board	30221000021	1
24	Main Board	30224000068	1
25	Terminal Board	4201025301	1

◆ Model: GKH48S3GI exploded view and spare parts list.

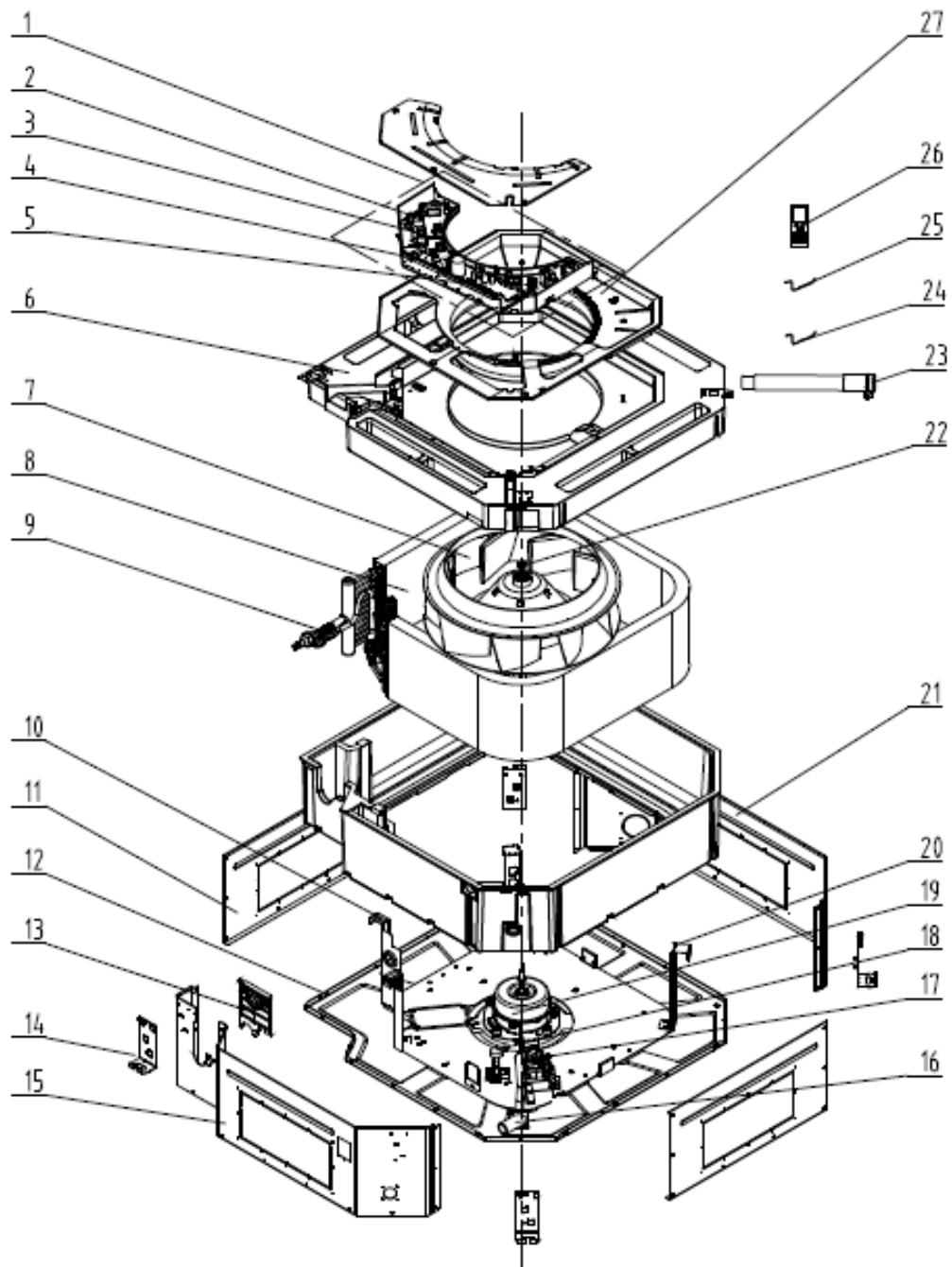

NO.	Name of Part	GKH48S3GI	
		Product Code	ET010N1180
		part Code	Quantity
1	Electric Box Assy	100002000122	1
2	Terminal Board	42010259	1
3	Terminal Board	4201025301	1
4	Filter Board	300020000001	1
5	Main Board	300002000132	1
6	Water Tray Assy	69000014	1
7	Centrifugal Fan	10429401	1
8	Evaporator Assy	1029400054	1
9	Strainer	7212403	1
10	Connection Sheet Sub-Assy	1349400002	1
11	Right and Let Side Plate	1319448	1
12	Seat Board Sub-Assy	2229400001	1
13	Tube Exit Plate Sub-Assy	2229400002	1
14	Body Installing Plate	1329420	4
15	Front Side Plate	1319447	1
16	Pump Drainpipe	200070000003	1
17	Water Pump	43138000058	1
18	Water Level Switch	4501801201	1
19	Brushless DC Motor	15709400009	1
20	Evaporator Support	1849406	3
21	Rear Side Plate	1319446	1
22	Fan Fixer	10312701	1
23	Drain Hose Sub-Assy	5232702	1
24	Temperature Sensor	390000453	1
25	Tube Sensor	39000286	1
26	Remote Controller	30510516	1
27	Diversion Circle	10479401	1



JF00302907

**GREE ELECTRIC APPLIANCES, INC. OF ZHUHAI**

Add: West Jinji Rd, Qianshan, Zhuhai, Guangdong, China, 519070

Tel: (+86-756) 8522218 Fax: (+86-756) 8669426

E-mail: [gree@gree.com.cn](mailto:gree@gree.com.cn) [www.gree.com](http://www.gree.com)

For continuous improvement in the products, Gree reserves the right to modify the product specification and appearance in this manual without notice and without incurring any obligations.